



wwPDB EM Validation Summary Report ⓘ

Mar 3, 2026 – 07:45 PM JST

PDB ID : 8Z60 / pdb_00008z60
EMDB ID : EMD-39790
Title : Cryo-EM structure of the polar flagellar motor-hook complex
Authors : Zhang, L.; Tan, J.X.; Zhou, Y.; Zhu, Y.Q.
Deposited on : 2024-04-18
Resolution : 3.22 Å (reported)
Based on initial model : .

This is a wwPDB EM Validation Summary Report for a publicly released PDB entry.

We welcome your comments at validation@mail.wwpdb.org

A user guide is available at

<https://www.wwpdb.org/validation/2017/EMValidationReportHelp>

with specific help available everywhere you see the ⓘ symbol.

The types of validation reports are described at

<http://www.wwpdb.org/validation/2017/FAQs#types>.

The following versions of software and data (see [references ⓘ](#)) were used in the production of this report:

EMDB validation analysis : 0.0.1.dev132
Mogul : 1.8.5 (274361), CSD as541be (2020)
MolProbity : 4-5-2 with Phenix2.0
buster-report : 1.1.7 (2018)
Percentile statistics : 20231227.v01 (using entries in the PDB archive December 27th 2023)
EM percentile statistics : 202505.v01 (Using data in the EMDB archive up until May 2025)
MapQ : 1.9.13
Ideal geometry (proteins) : Engh & Huber (2001)
Ideal geometry (DNA, RNA) : Parkinson et al. (1996)
Validation Pipeline (wwPDB-VP) : 2.48.1

1 Overall quality at a glance

The following experimental techniques were used to determine the structure:
ELECTRON MICROSCOPY

The reported resolution of this entry is 3.22 Å.

Percentile scores (ranging between 0-100) for global validation metrics of the entry are shown in the following graphic. The table shows the number of entries on which the scores are based.

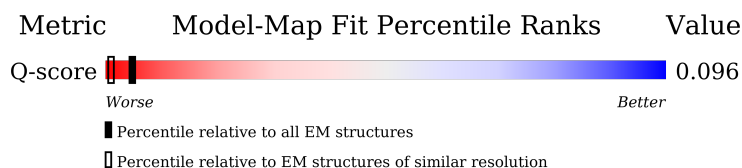
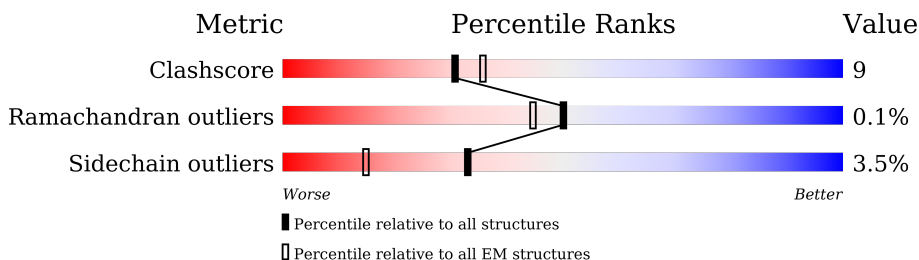













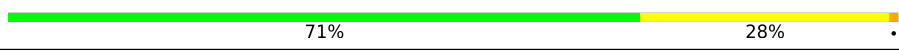
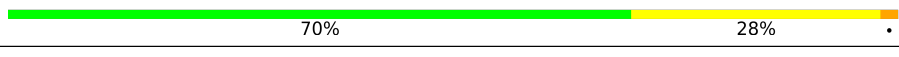



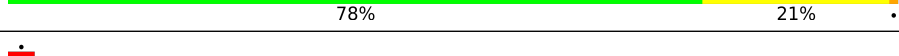
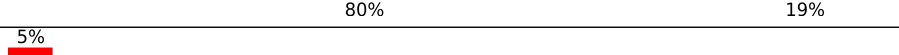
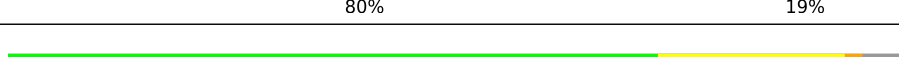
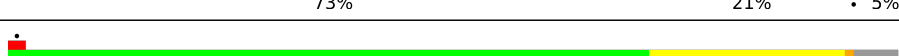

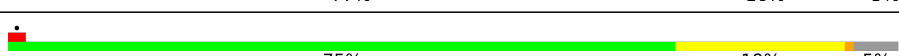
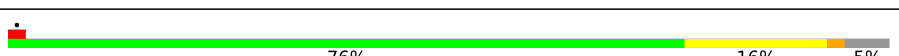
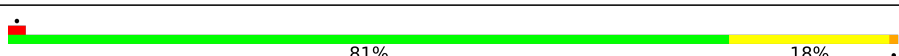
Metric	Whole archive (#Entries)	EM structures (#Entries)	Similar EM resolution (#Entries, resolution range(Å))
Clashscore	210492	15764	-
Ramachandran outliers	207382	16835	-
Sidechain outliers	206894	16415	-
Q-score	-	25397	14612 (2.72 - 3.72)

The table below summarises the geometric issues observed across the polymeric chains and their fit to the map. The red, orange, yellow and green segments of the bar indicate the fraction of residues that contain outliers for ≥ 3 , 2, 1 and 0 types of geometric quality criteria respectively. A grey segment represents the fraction of residues that are not modelled. The numeric value for each fraction is indicated below the corresponding segment, with a dot representing fractions $\leq 5\%$. The upper red bar (where present) indicates the fraction of residues that have poor fit to the EM map (all-atom inclusion $< 40\%$). The numeric value is given above the bar.

Mol	Chain	Length	Quality of chain
1	0	199	80% (poor fit) 68% (0 outliers), 21% (1 outlier), 10% (2+ outliers), 1% (not modelled)
1	9	199	72% (0 outliers), 17% (1 outlier), 10% (2+ outliers), 1% (not modelled)
2	1	289	7% (poor fit), 57% (0 outliers), 14% (1 outlier), 28% (2+ outliers), 1% (not modelled)
2	2	289	6% (poor fit), 56% (0 outliers), 15% (1 outlier), 28% (2+ outliers), 1% (not modelled)

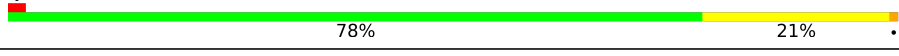

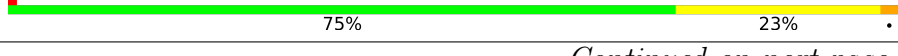







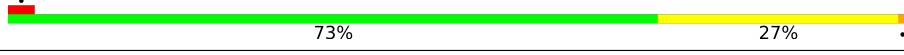

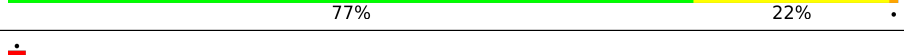
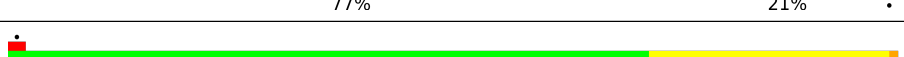
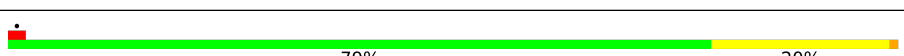







Continued on next page...

Continued from previous page...

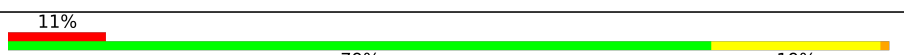
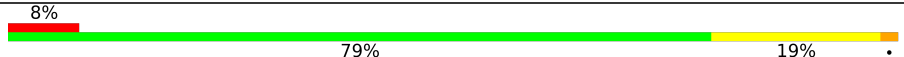
Mol	Chain	Length	Quality of chain
2	3	289	 56% 15% 28%
2	y	289	 57% 14% 28%
2	z	289	 54% 17% 28%
3	4	89	 71% 28%
3	5	89	 70% 28%
3	6	89	 70% 28%
3	7	89	 78% 22%
4	8	260	 69% 22% 7%
5	A	262	 78% 21%
5	AP	262	 80% 19%
5	AQ	262	 5% 80% 19%
5	AR	262	 73% 21% 5%
5	AS	262	 72% 22% 5%
5	AT	262	 77% 16% 5%
5	AU	262	 75% 19% 5%
5	AV	262	 76% 16% 5%
5	AW	262	 81% 18%
5	AX	262	 79% 19%
5	AY	262	 76% 23%
5	AZ	262	 74% 24%
5	Aa	262	 73% 26%
5	B	262	 76% 23%
5	C	262	 78% 21%
5	P	262	 71% 28%
5	Q	262	 75% 23%

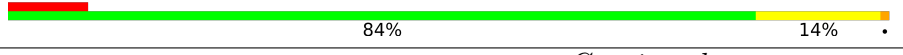









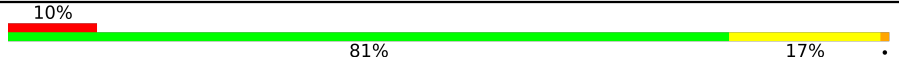
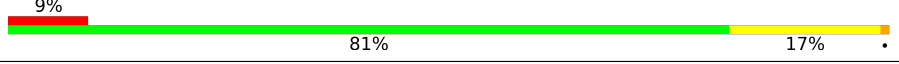
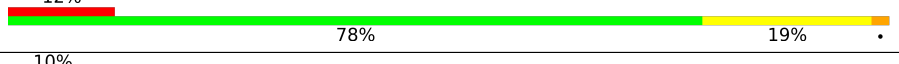

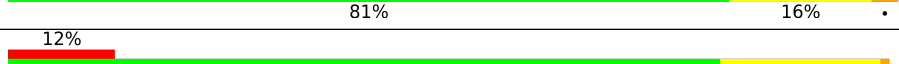
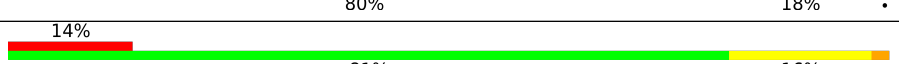
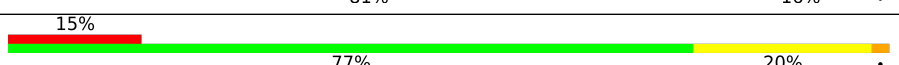
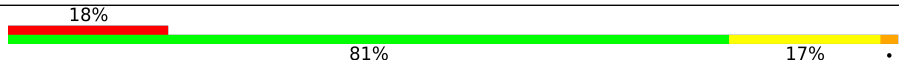

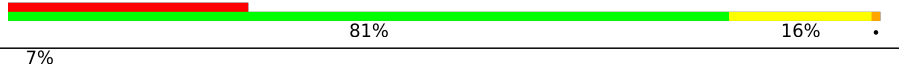
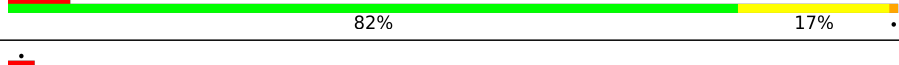

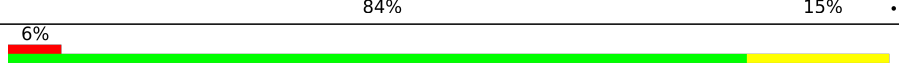
Continued on next page...

Continued from previous page...

Mol	Chain	Length	Quality of chain
5	R	262	 81% 18%
5	S	262	 73% 27%
5	T	262	 68% 30%
5	U	262	 77% 22%
5	V	262	 77% 21%
5	W	262	 72% 27%
5	X	262	 79% 20%
5	Y	262	 80% 18%
5	Z	262	 84% 14%
5	a	262	 79% 20%
6	A1	437	 31% 80%
6	A2	437	 35% 80%
6	A3	437	 36% 78%
6	Ab	437	 5% 81%
6	Ac	437	 8% 77%
6	Ad	437	 9% 79%
6	Ae	437	 10% 82%
6	Af	437	 9% 78%
6	Ag	437	 6% 80%
6	Ah	437	 6% 83%
6	Ai	437	 8% 80%
6	Aj	437	 11% 79%
6	Ak	437	 8% 79%
6	Al	437	 9% 82%
6	Am	437	 9% 84%









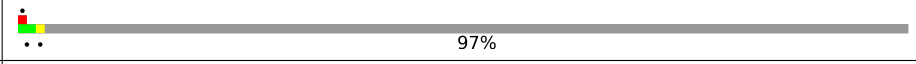
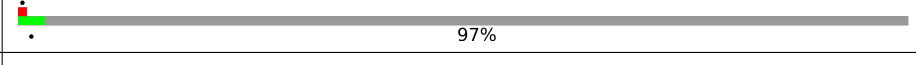
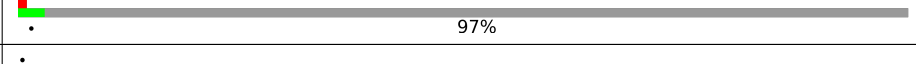
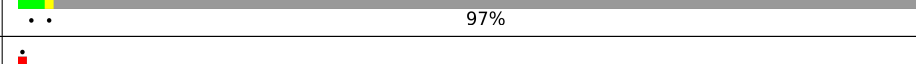
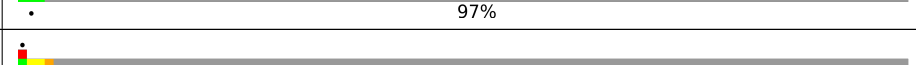
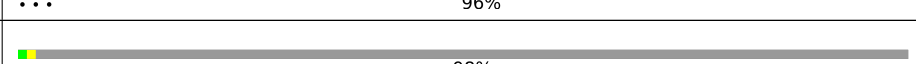
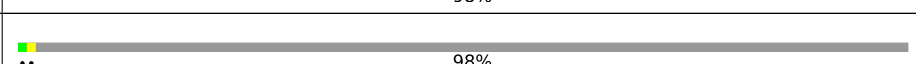
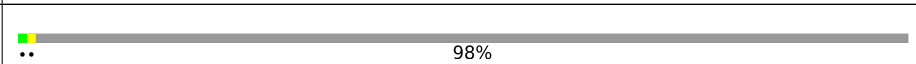
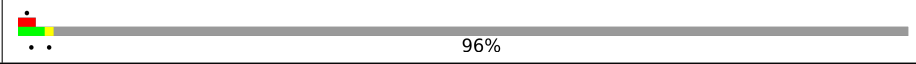
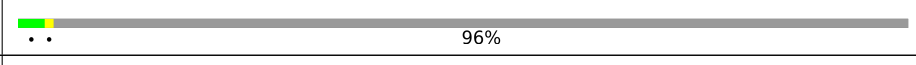
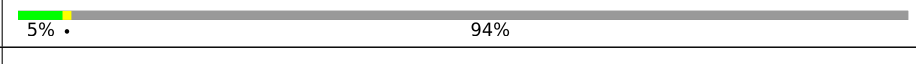
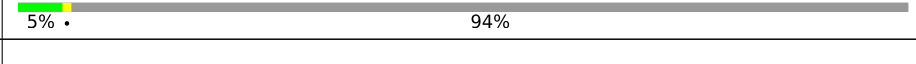
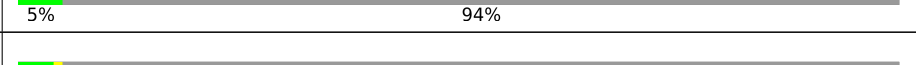
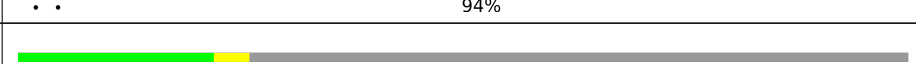
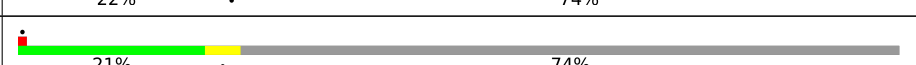
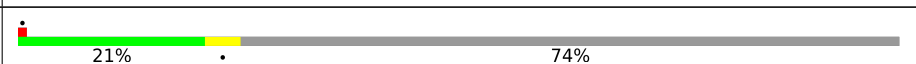

Continued on next page...

Continued from previous page...

Mol	Chain	Length	Quality of chain
6	An	437	 10% 81% 17%
6	Ao	437	 9% 81% 17%
6	Ap	437	 12% 78% 19%
6	Aq	437	 10% 80% 18%
6	Ar	437	 13% 81% 17%
6	As	437	 9% 81% 16%
6	At	437	 12% 80% 18%
6	Au	437	 14% 81% 16%
6	Av	437	 15% 77% 20%
6	Aw	437	 18% 81% 17%
6	Ax	437	 19% 81% 18%
6	Ay	437	 22% 76% 22%
6	Az	437	 27% 81% 16%
6	D	437	 7% 82% 17%
6	E	437	 0% 84% 15%
6	F	437	 5% 84% 15%
6	G	437	 6% 83% 16%
6	H	437	 7% 84% 15%
6	I	437	 7% 82% 16%
6	J	437	 6% 84% 15%
6	K	437	 7% 81% 18%
6	L	437	 8% 81% 16%
6	M	437	 6% 82% 16%
6	N	437	 7% 85% 14%
6	O	437	 7% 84% 14%

















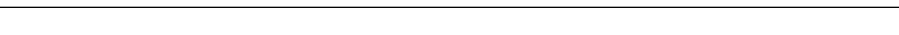
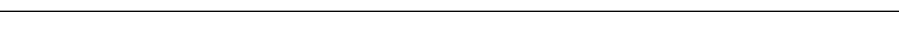
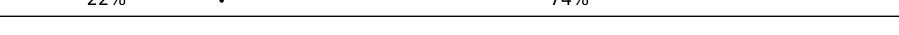
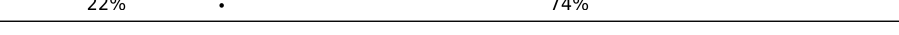
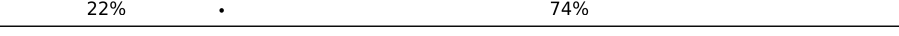



Continued on next page...

Continued from previous page...

Mol	Chain	Length	Quality of chain
7	AA	580	 97%
7	AB	580	 97%
7	AC	580	 97%
7	AD	580	 97%
7	AE	580	 97%
7	AF	580	 96%
7	AG	580	 98%
7	AH	580	 98%
7	AI	580	 98%
7	AJ	580	 96%
7	AK	580	 96%
7	AL	580	 94%
7	AM	580	 94%
7	AN	580	 94%
7	AO	580	 94%
7	D1	580	 74%
7	D2	580	 74%
7	D3	580	 74%
7	D4	580	 74%
7	D5	580	 74%
7	Dz	580	 74%
7	E1	580	 74%
7	E2	580	 74%
7	E3	580	 74%
7	E4	580	 74%

Continued on next page...

Continued from previous page...

Mol	Chain	Length	Quality of chain
7	E5	580	 22% 74%
7	EG	580	 21% 74%
7	EH	580	 22% 74%
7	EI	580	 22% 74%
7	EJ	580	 21% 74%
7	EK	580	 21% 74%
7	EL	580	 21% 74%
7	EM	580	 21% 74%
7	EN	580	 22% 74%
7	EO	580	 22% 74%
7	EP	580	 22% 74%
7	EQ	580	 22% 74%
7	ER	580	 21% 74%
7	ES	580	 21% 74%
7	ET	580	 22% 74%
7	EU	580	 22% 74%
7	EV	580	 22% 74%
7	EW	580	 22% 74%
7	EX	580	 11% 7% 80%
7	EY	580	 9% 9% 80%
7	EZ	580	 12% 7% 80%
7	Ea	580	 12% 7% 80%
7	Eb	580	 11% 7% 80%
7	Ec	580	 12% 5% 81%
7	Ed	580	 12% 6% 80%











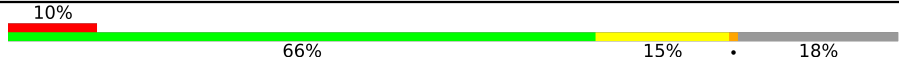

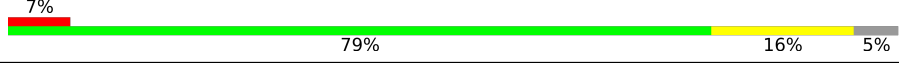

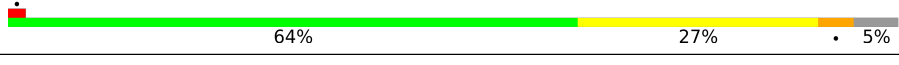
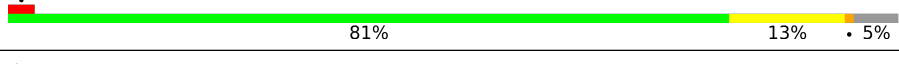
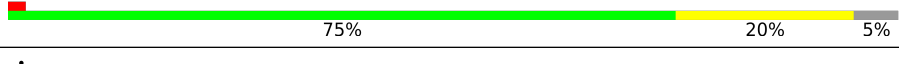

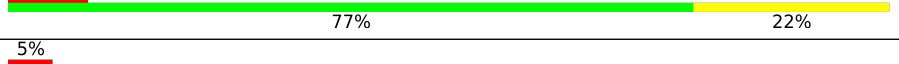
Continued on next page...

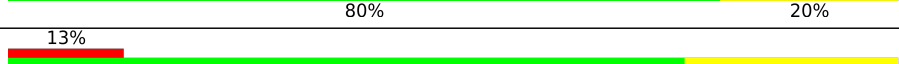
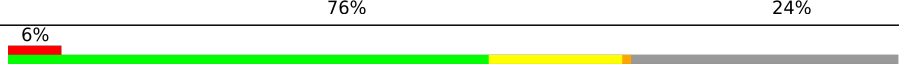
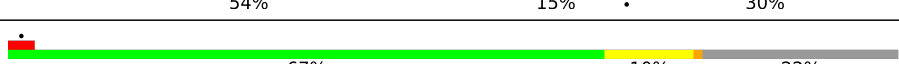
Continued from previous page...

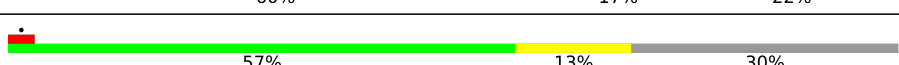
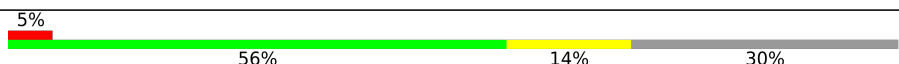
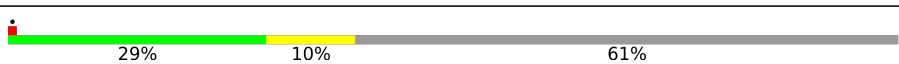
Mol	Chain	Length	Quality of chain
7	Ee	580	12% 6% 80%
7	Ef	580	13% 7% 80%
7	Eg	580	11% 5% 84%
7	Eh	580	10% 7% 82%
7	Ei	580	10% 7% 82%
7	Ej	580	10% 7% 82%
7	Ek	580	9% 6% 85%
7	El	580	10% 5% 84%
7	Em	580	9% 6% 84%
7	En	580	9% 6% 85%
7	Eo	580	10% 6% 84%
7	Ep	580	12% 7% 80%
7	Eq	580	12% 7% 80%
7	Er	580	13% 6% 80%
7	Es	580	10% 8% 82%
7	Et	580	12% 6% 80%
7	Eu	580	22% 5% 74%
7	Ev	580	21% 4% 74%
7	Ew	580	22% 5% 74%
7	Ex	580	21% 5% 74%
7	Ey	580	22% 4% 74%
7	Ez	580	22% 4% 74%
8	b	131	14% 69% 14% 17%
8	c	131	7% 63% 18% 18%
8	d	131	8% 69% 15% 17%

Continued on next page...

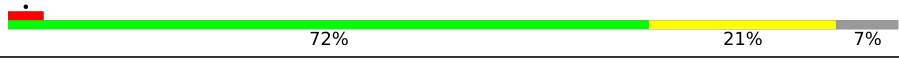
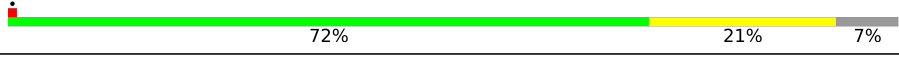
Continued from previous page...

Mol	Chain	Length	Quality of chain
8	e	131	
8	f	131	
9	g	137	
9	h	137	
9	i	137	
9	j	137	
9	k	137	
9	l	137	
10	m	249	
10	n	249	
10	o	249	
10	p	249	
10	q	249	
11	r	103	
11	s	103	
11	t	103	
11	u	103	
11	v	103	
11	w	103	
12	x	376	
13	A8	377	
13	B1	377	
13	B6	377	
13	B7	377	
13	BC	377	

















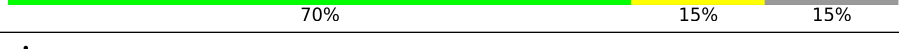
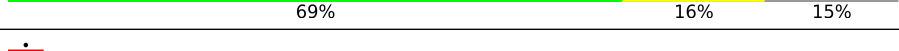
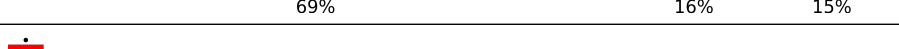
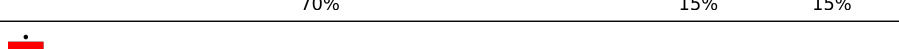
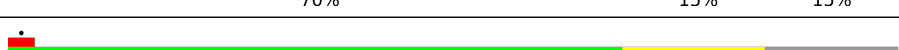

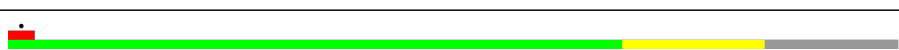
Continued on next page...

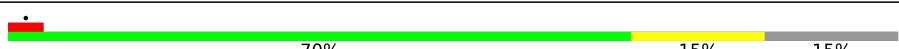
Continued from previous page...

Mol	Chain	Length	Quality of chain		
13	BH	377	5%	73%	20% 7%
13	BM	377	5%	74%	19% 7%
13	BR	377	5%	73%	20% 7%
13	BW	377	5%	73%	20% 7%
13	Bb	377	•	72%	21% 7%
13	Bg	377	•	71%	22% 7%
13	Bl	377	•	72%	21% 7%
13	Bq	377	•	73%	20% 7%
13	Bv	377	•	73%	20% 7%
13	C3	377	•	73%	20% 7%
13	C8	377	6%	73%	20% 7%
13	CB	377	•	73%	20% 7%
13	CJ	377	•	72%	21% 7%
13	CO	377	•	74%	19% 7%
13	CT	377	5%	72%	21% 7%
13	CY	377	5%	73%	20% 7%
13	Cd	377	5%	73%	20% 7%
13	Ci	377	•	72%	21% 7%
13	Cn	377	•	72%	21% 7%
13	Cs	377	•	72%	21% 7%
13	Cx	377	•	73%	20% 7%
14	A4	259	•	69%	17% 15%
14	A9	259	•	69%	16% 15%
14	B2	259	•	70%	15% 15%
14	B8	259	•	69%	16% 15%



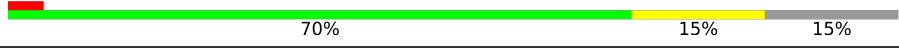
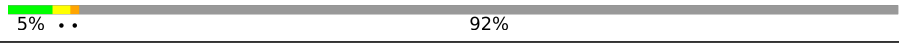
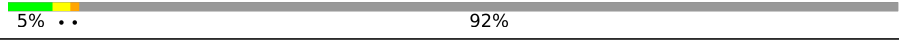
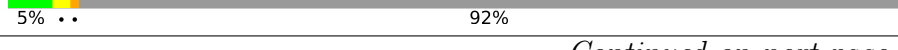













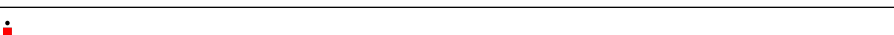
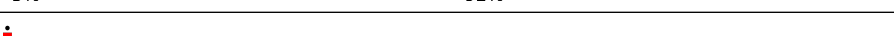
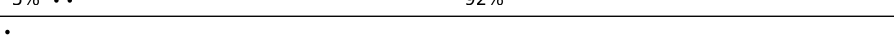
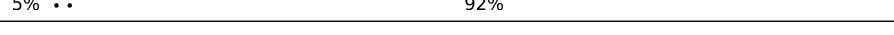
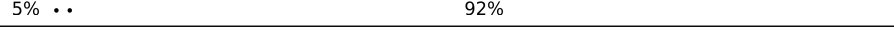

Continued on next page...

Continued from previous page...

Mol	Chain	Length	Quality of chain
14	BD	259	 69% 16% 15%
14	BI	259	 70% 15% 15%
14	BN	259	 69% 16% 15%
14	BS	259	 69% 17% 15%
14	BX	259	 69% 16% 15%
14	Bc	259	 70% 15% 15%
14	Bh	259	 70% 15% 15%
14	Bm	259	 69% 16% 15%
14	Br	259	 69% 16% 15%
14	Bw	259	 70% 15% 15%
14	C4	259	 70% 15% 15%
14	C9	259	 69% 16% 15%
14	CC	259	 70% 15% 15%
14	CK	259	 69% 16% 15%
14	CP	259	 69% 16% 15%
14	CU	259	 70% 15% 15%
14	CZ	259	 69% 16% 15%
14	Ce	259	 69% 16% 15%
14	Cj	259	 70% 15% 15%
14	Co	259	 70% 15% 15%
14	Ct	259	 70% 15% 15%
14	Cy	259	 70% 15% 15%
15	A0	143	 5% .. 92%
15	A5	143	 5% .. 92%
15	B3	143	 5% .. 92%

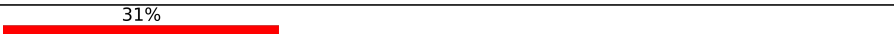

Continued on next page...

Continued from previous page...

Mol	Chain	Length	Quality of chain
15	B9	143	 5% .. 92%
15	BE	143	 5% .. 92%
15	BJ	143	 5% .. 92%
15	BO	143	 5% .. 92%
15	BT	143	 5% .. 92%
15	BY	143	 5% .. 92%
15	Bd	143	 5% .. 92%
15	Bi	143	 5% .. 92%
15	Bn	143	 5% .. 92%
15	Bs	143	 5% .. 92%
15	Bx	143	 5% .. 92%
15	C0	143	 5% .. 92%
15	C5	143	 5% .. 92%
15	CD	143	 5% .. 92%
15	CL	143	 5% .. 92%
15	CQ	143	 5% .. 92%
15	CV	143	 5% .. 92%
15	Ca	143	 5% .. 92%
15	Cf	143	 5% .. 92%
15	Ck	143	 5% .. 92%
15	Cp	143	 5% .. 92%
15	Cu	143	 5% .. 92%
15	Cz	143	 5% .. 92%
16	A6	13	 31% 92% 8%
16	B0	13	 31% 92% 8%



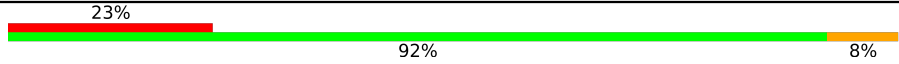
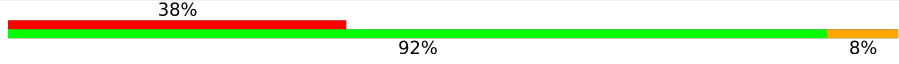
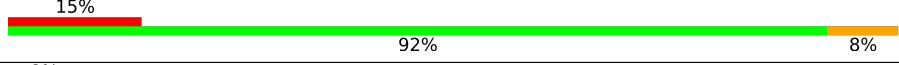
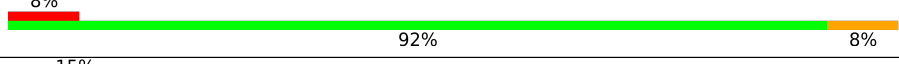
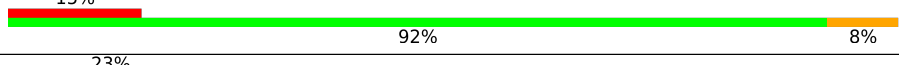
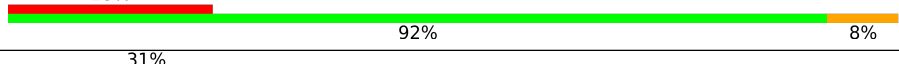
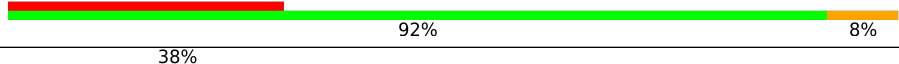
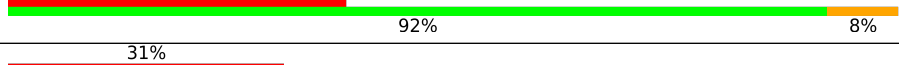
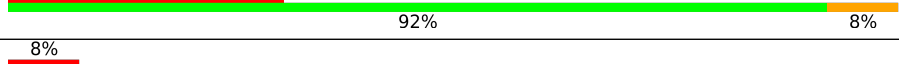
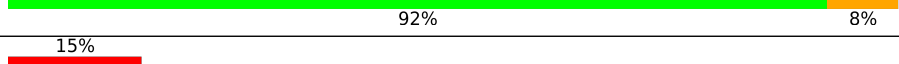
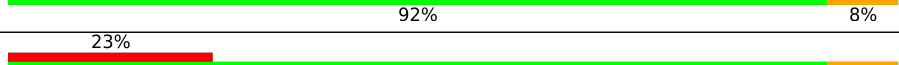
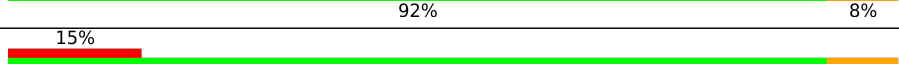
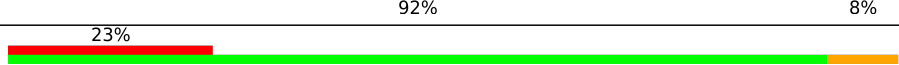
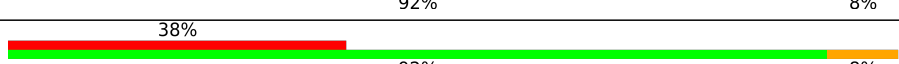
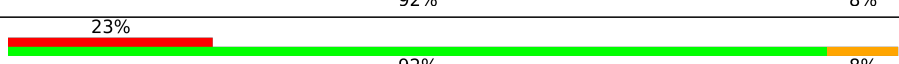
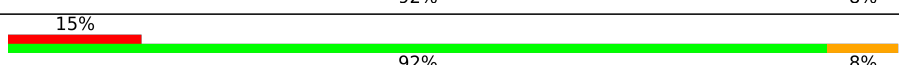
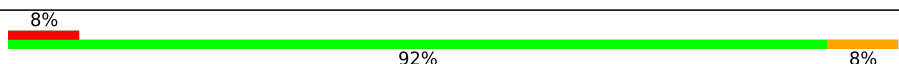
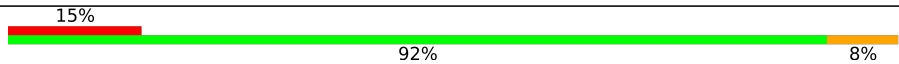
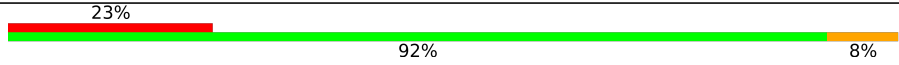
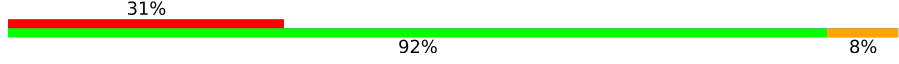
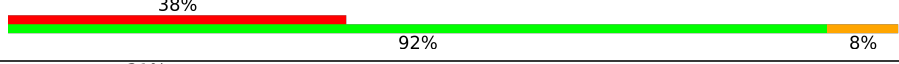
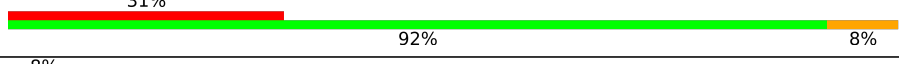
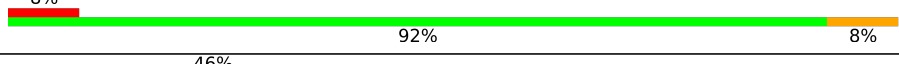









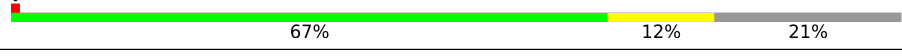
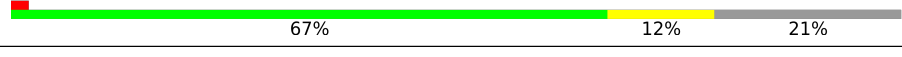



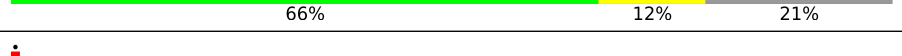
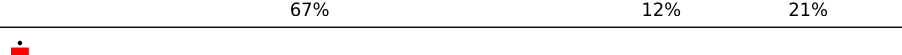
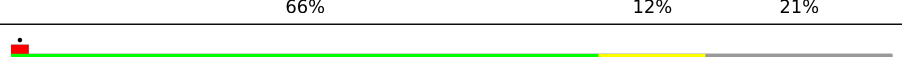
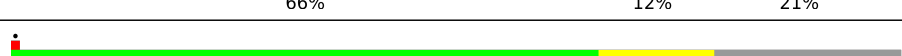

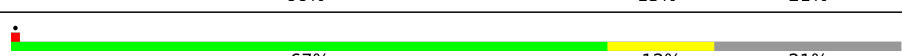
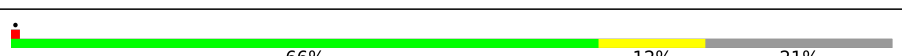
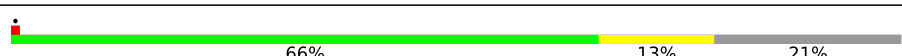
Continued on next page...

Continued from previous page...

Mol	Chain	Length	Quality of chain
16	B4	13	
16	BA	13	
16	BF	13	
16	BK	13	
16	BP	13	
16	BU	13	
16	BZ	13	
16	Be	13	
16	Bj	13	
16	Bo	13	
16	Bt	13	
16	By	13	
16	C1	13	
16	C6	13	
16	CE	13	
16	CH	13	
16	CM	13	
16	CR	13	
16	CW	13	
16	Cb	13	
16	Cg	13	
16	Cl	13	
16	Cq	13	
16	Cv	13	
16	D0	13	

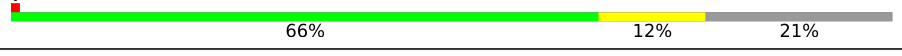
Continued on next page...

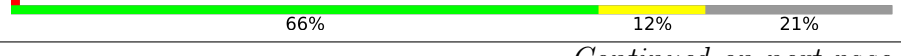
Continued from previous page...

Mol	Chain	Length	Quality of chain
17	A7	363	 67% 12% 21%
17	B5	363	 66% 13% 21%
17	BB	363	 67% 12% 21%
17	BG	363	 67% 12% 21%
17	BL	363	 67% 12% 21%
17	BQ	363	 67% 12% 21%
17	BV	363	 66% 12% 21%
17	Ba	363	 66% 12% 21%
17	Bf	363	 66% 12% 21%
17	Bk	363	 67% 12% 21%
17	Bp	363	 66% 12% 21%
17	Bu	363	 66% 12% 21%
17	Bz	363	 66% 13% 21%
17	C2	363	 66% 13% 21%
17	C7	363	 67% 12% 21%
17	CA	363	 66% 12% 21%
17	CF	363	 66% 13% 21%
17	CI	363	 67% 12% 21%
17	CN	363	 66% 13% 21%
17	CS	363	 65% 13% 21%
17	CX	363	 66% 13% 21%
17	Cc	363	 66% 13% 21%
17	Ch	363	 66% 12% 21%
17	Cm	363	 66% 12% 21%
17	Cr	363	 66% 12% 21%

















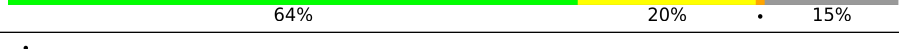
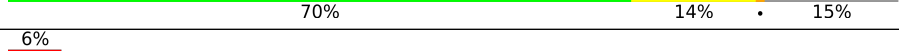
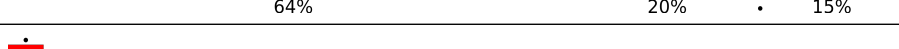
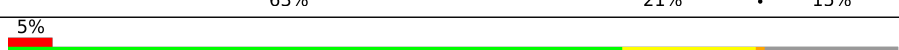

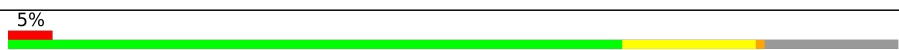
Continued on next page...

Continued from previous page...

Mol	Chain	Length	Quality of chain
17	Cw	363	66% 13% 21%
18	CG	293	74% 18% 8%
18	DA	293	71% 21% 8%
18	DD	293	73% 18% 8%
18	DE	293	71% 20% 8%
18	DH	293	73% 18% 8%
18	DI	293	71% 20% 8%
18	DL	293	74% 18% 8%
18	DM	293	71% 20% 8%
18	DP	293	73% 18% 8%
18	DQ	293	70% 22% 8%
18	DT	293	73% 18% 8%
18	DU	293	70% 21% 8%
18	DX	293	73% 18% 8%
18	DY	293	71% 20% 8%
18	Db	293	74% 17% 8%
18	Dc	293	71% 21% 8%
18	Df	293	74% 17% 8%
18	Dg	293	70% 21% 8%
18	Dj	293	73% 18% 8%
18	Dk	293	72% 20% 8%
18	Dn	293	74% 17% 8%
18	Do	293	71% 20% 8%
18	Dr	293	73% 18% 8%
18	Ds	293	70% 21% 8%

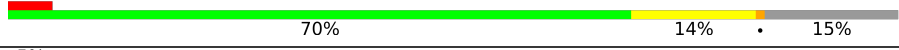
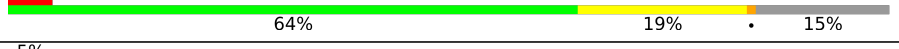







Continued on next page...

Continued from previous page...

Mol	Chain	Length	Quality of chain
18	Dv	293	 74% 17% 8%
18	Dw	293	 71% 20% 8%
19	DB	211	 63% 21% 15%
19	DC	211	 6% 71% 13% 15%
19	DF	211	 6% 64% 20% 15%
19	DG	211	 70% 14% 15%
19	DJ	211	 7% 64% 20% 15%
19	DK	211	 70% 14% 15%
19	DN	211	 6% 64% 20% 15%
19	DO	211	 71% 13% 15%
19	DR	211	 8% 63% 21% 15%
19	DS	211	 5% 69% 15% 15%
19	DV	211	 5% 63% 21% 15%
19	DW	211	 5% 69% 15% 15%
19	DZ	211	 63% 21% 15%
19	Da	211	 71% 13% 15%
19	Dd	211	 6% 64% 20% 15%
19	De	211	 6% 70% 14% 15%
19	Dh	211	 6% 63% 21% 15%
19	Di	211	 70% 14% 15%
19	Dl	211	 64% 20% 15%
19	Dm	211	 5% 70% 14% 15%
19	Dp	211	 5% 64% 19% 15%
19	Dq	211	 5% 68% 16% 15%
19	Dt	211	 5% 64% 20% 15%

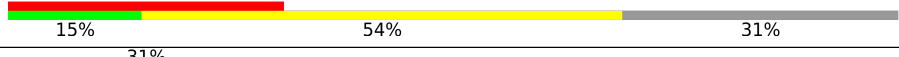
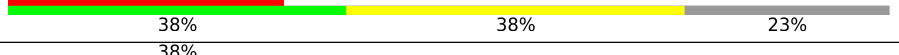
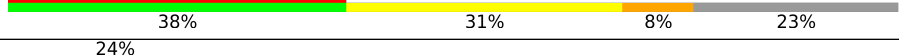
Continued on next page...

Continued from previous page...

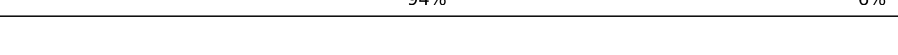
Mol	Chain	Length	Quality of chain
19	Du	211	 69% 15% 15%
19	Dx	211	 65% 19% 15%
19	Dy	211	 70% 14% 15%
20	D6	13	 38% 38% 15% 8%
20	D7	13	 31% 15% 54% 31%
20	D8	13	 31% 38% 38% 23%
20	D9	13	 38% 38% 31% 8% 23%
21	EA	17	 24% 88% 12%
21	EB	17	 24% 82% 18%
21	EC	17	 24% 88% 12%
21	ED	17	 47% 94% 6%
21	EE	17	 71% 88% 12%
21	EF	17	 65% 94% 6%

2 Entry composition i

There are 23 unique types of molecules in this entry. The entry contains 555596 atoms, of which 0 are hydrogens and 0 are deuteriums.

In the tables below, the AltConf column contains the number of residues with at least one atom in alternate conformation and the Trace column contains the number of residues modelled with at most 2 atoms.

- Molecule 1 is a protein called LRR.

Mol	Chain	Residues	Atoms					AltConf	Trace
			Total	C	N	O	S		
1	0	180	1361	876	231	253	1	0	0
1	9	180	1361	876	231	253	1	0	0

- Molecule 2 is a protein called Flagellar biosynthetic protein FliP.

Mol	Chain	Residues	Atoms					AltConf	Trace
			Total	C	N	O	S		
2	1	207	1599	1055	243	282	19	0	0
2	2	208	1608	1060	244	285	19	0	0
2	3	208	1608	1060	244	285	19	0	0
2	y	208	1608	1060	244	285	19	0	0
2	z	208	1608	1060	244	285	19	0	0

There are 10 discrepancies between the modelled and reference sequences:

Chain	Residue	Modelled	Actual	Comment	Reference
1	26	SER	THR	conflict	UNP A0A1W6TTE6
1	204	ASP	GLU	conflict	UNP A0A1W6TTE6
2	26	SER	THR	conflict	UNP A0A1W6TTE6
2	204	ASP	GLU	conflict	UNP A0A1W6TTE6
3	26	SER	THR	conflict	UNP A0A1W6TTE6
3	204	ASP	GLU	conflict	UNP A0A1W6TTE6
y	26	SER	THR	conflict	UNP A0A1W6TTE6
y	204	ASP	GLU	conflict	UNP A0A1W6TTE6
z	26	SER	THR	conflict	UNP A0A1W6TTE6
z	204	ASP	GLU	conflict	UNP A0A1W6TTE6

- Molecule 3 is a protein called Flagellar biosynthetic protein FliQ.

Mol	Chain	Residues	Atoms					AltConf	Trace
3	4	89	Total	C	N	O	S	0	0
			722	489	107	117	9		
3	5	89	Total	C	N	O	S	0	0
			722	489	107	117	9		
3	6	89	Total	C	N	O	S	0	0
			722	489	107	117	9		
3	7	89	Total	C	N	O	S	0	0
			722	489	107	117	9		

There are 4 discrepancies between the modelled and reference sequences:

Chain	Residue	Modelled	Actual	Comment	Reference
4	34	ILE	VAL	conflict	UNP A0A0H0YAF4
5	34	ILE	VAL	conflict	UNP A0A0H0YAF4
6	34	ILE	VAL	conflict	UNP A0A0H0YAF4
7	34	ILE	VAL	conflict	UNP A0A0H0YAF4

- Molecule 4 is a protein called Flagellar biosynthetic protein FliR.

Mol	Chain	Residues	Atoms					AltConf	Trace
4	8	242	Total	C	N	O	S	0	0
			1896	1265	295	315	21		

- Molecule 5 is a protein called Flagellar basal-body rod protein FlgG.

Mol	Chain	Residues	Atoms					AltConf	Trace
5	A	262	Total	C	N	O	S	0	0
			1956	1208	334	405	9		
5	AP	262	Total	C	N	O	S	0	0
			1956	1208	334	405	9		
5	AQ	262	Total	C	N	O	S	0	0
			1956	1208	334	405	9		
5	AR	248	Total	C	N	O	S	0	0
			1858	1151	317	382	8		
5	AS	248	Total	C	N	O	S	0	0
			1858	1151	317	382	8		
5	AT	249	Total	C	N	O	S	0	0
			1866	1156	318	383	9		
5	AU	248	Total	C	N	O	S	0	0
			1858	1151	317	382	8		
5	AV	248	Total	C	N	O	S	0	0
			1858	1151	317	382	8		

Continued on next page...

Continued from previous page...

Mol	Chain	Residues	Atoms					AltConf	Trace
5	AW	262	Total 1956	C 1208	N 334	O 405	S 9	0	0
5	AX	262	Total 1956	C 1208	N 334	O 405	S 9	0	0
5	AY	262	Total 1956	C 1208	N 334	O 405	S 9	0	0
5	AZ	262	Total 1956	C 1208	N 334	O 405	S 9	0	0
5	Aa	262	Total 1956	C 1208	N 334	O 405	S 9	0	0
5	B	262	Total 1956	C 1208	N 334	O 405	S 9	0	0
5	C	262	Total 1956	C 1208	N 334	O 405	S 9	0	0
5	P	262	Total 1956	C 1208	N 334	O 405	S 9	0	0
5	Q	262	Total 1956	C 1208	N 334	O 405	S 9	0	0
5	R	262	Total 1956	C 1208	N 334	O 405	S 9	0	0
5	S	262	Total 1956	C 1208	N 334	O 405	S 9	0	0
5	T	262	Total 1956	C 1208	N 334	O 405	S 9	0	0
5	U	262	Total 1956	C 1208	N 334	O 405	S 9	0	0
5	V	262	Total 1956	C 1208	N 334	O 405	S 9	0	0
5	W	262	Total 1956	C 1208	N 334	O 405	S 9	0	0
5	X	262	Total 1956	C 1208	N 334	O 405	S 9	0	0
5	Y	262	Total 1956	C 1208	N 334	O 405	S 9	0	0
5	Z	262	Total 1956	C 1208	N 334	O 405	S 9	0	0
5	a	262	Total 1956	C 1208	N 334	O 405	S 9	0	0

- Molecule 6 is a protein called Flagellar hook protein FlgE.

Mol	Chain	Residues	Atoms					AltConf	Trace
			Total	C	N	O	S		
6	A1	435	3319	2052	563	696	8	0	0
6	A2	435	3319	2052	563	696	8	0	0
6	A3	435	3319	2052	563	696	8	0	0
6	Ab	435	3319	2052	563	696	8	0	0
6	Ac	435	3319	2052	563	696	8	0	0
6	Ad	435	3319	2052	563	696	8	0	0
6	Ae	435	3319	2052	563	696	8	0	0
6	Af	435	3319	2052	563	696	8	0	0
6	Ag	435	3319	2052	563	696	8	0	0
6	Ah	435	3319	2052	563	696	8	0	0
6	Ai	435	3319	2052	563	696	8	0	0
6	Aj	435	3319	2052	563	696	8	0	0
6	Ak	435	3319	2052	563	696	8	0	0
6	Al	435	3319	2052	563	696	8	0	0
6	Am	435	3319	2052	563	696	8	0	0
6	An	435	3319	2052	563	696	8	0	0
6	Ao	435	3319	2052	563	696	8	0	0
6	Ap	435	3319	2052	563	696	8	0	0
6	Aq	435	3319	2052	563	696	8	0	0
6	Ar	435	3319	2052	563	696	8	0	0
6	As	435	3319	2052	563	696	8	0	0
6	At	435	3319	2052	563	696	8	0	0

Continued on next page...

Continued from previous page...

Mol	Chain	Residues	Atoms					AltConf	Trace
6	Au	435	Total 3319	C 2052	N 563	O 696	S 8	0	0
6	Av	435	Total 3319	C 2052	N 563	O 696	S 8	0	0
6	Aw	435	Total 3319	C 2052	N 563	O 696	S 8	0	0
6	Ax	435	Total 3319	C 2052	N 563	O 696	S 8	0	0
6	Ay	435	Total 3319	C 2052	N 563	O 696	S 8	0	0
6	Az	435	Total 3319	C 2052	N 563	O 696	S 8	0	0
6	D	435	Total 3319	C 2052	N 563	O 696	S 8	0	0
6	E	435	Total 3319	C 2052	N 563	O 696	S 8	0	0
6	F	435	Total 3319	C 2052	N 563	O 696	S 8	0	0
6	G	435	Total 3319	C 2052	N 563	O 696	S 8	0	0
6	H	435	Total 3319	C 2052	N 563	O 696	S 8	0	0
6	I	435	Total 3319	C 2052	N 563	O 696	S 8	0	0
6	J	435	Total 3319	C 2052	N 563	O 696	S 8	0	0
6	K	435	Total 3319	C 2052	N 563	O 696	S 8	0	0
6	L	435	Total 3319	C 2052	N 563	O 696	S 8	0	0
6	M	435	Total 3319	C 2052	N 563	O 696	S 8	0	0
6	N	435	Total 3319	C 2052	N 563	O 696	S 8	0	0
6	O	435	Total 3319	C 2052	N 563	O 696	S 8	0	0

There are 40 discrepancies between the modelled and reference sequences:

Chain	Residue	Modelled	Actual	Comment	Reference
A1	335	MET	LEU	conflict	UNP A0A0H0YA78
A2	335	MET	LEU	conflict	UNP A0A0H0YA78
A3	335	MET	LEU	conflict	UNP A0A0H0YA78

Continued on next page...

Continued from previous page...

Chain	Residue	Modelled	Actual	Comment	Reference
Ab	335	MET	LEU	conflict	UNP A0A0H0YA78
Ac	335	MET	LEU	conflict	UNP A0A0H0YA78
Ad	335	MET	LEU	conflict	UNP A0A0H0YA78
Ae	335	MET	LEU	conflict	UNP A0A0H0YA78
Af	335	MET	LEU	conflict	UNP A0A0H0YA78
Ag	335	MET	LEU	conflict	UNP A0A0H0YA78
Ah	335	MET	LEU	conflict	UNP A0A0H0YA78
Ai	335	MET	LEU	conflict	UNP A0A0H0YA78
Aj	335	MET	LEU	conflict	UNP A0A0H0YA78
Ak	335	MET	LEU	conflict	UNP A0A0H0YA78
Al	335	MET	LEU	conflict	UNP A0A0H0YA78
Am	335	MET	LEU	conflict	UNP A0A0H0YA78
An	335	MET	LEU	conflict	UNP A0A0H0YA78
Ao	335	MET	LEU	conflict	UNP A0A0H0YA78
Ap	335	MET	LEU	conflict	UNP A0A0H0YA78
Aq	335	MET	LEU	conflict	UNP A0A0H0YA78
Ar	335	MET	LEU	conflict	UNP A0A0H0YA78
As	335	MET	LEU	conflict	UNP A0A0H0YA78
At	335	MET	LEU	conflict	UNP A0A0H0YA78
Au	335	MET	LEU	conflict	UNP A0A0H0YA78
Av	335	MET	LEU	conflict	UNP A0A0H0YA78
Aw	335	MET	LEU	conflict	UNP A0A0H0YA78
Ax	335	MET	LEU	conflict	UNP A0A0H0YA78
Ay	335	MET	LEU	conflict	UNP A0A0H0YA78
Az	335	MET	LEU	conflict	UNP A0A0H0YA78
D	335	MET	LEU	conflict	UNP A0A0H0YA78
E	335	MET	LEU	conflict	UNP A0A0H0YA78
F	335	MET	LEU	conflict	UNP A0A0H0YA78
G	335	MET	LEU	conflict	UNP A0A0H0YA78
H	335	MET	LEU	conflict	UNP A0A0H0YA78
I	335	MET	LEU	conflict	UNP A0A0H0YA78
J	335	MET	LEU	conflict	UNP A0A0H0YA78
K	335	MET	LEU	conflict	UNP A0A0H0YA78
L	335	MET	LEU	conflict	UNP A0A0H0YA78
M	335	MET	LEU	conflict	UNP A0A0H0YA78
N	335	MET	LEU	conflict	UNP A0A0H0YA78
O	335	MET	LEU	conflict	UNP A0A0H0YA78

- Molecule 7 is a protein called Flagellar M-ring protein.

Mol	Chain	Residues	Atoms					AltConf	Trace
			Total	C	N	O	S		
7	AA	19	135	82	23	29	1	0	0

Continued on next page...

Continued from previous page...

Mol	Chain	Residues	Atoms					AltConf	Trace
7	AB	19	Total	C	N	O	S	0	0
			135	82	23	29	1		
7	AC	20	Total	C	N	O	S	0	0
			139	84	24	30	1		
7	AD	19	Total	C	N	O	S	0	0
			135	82	23	29	1		
7	AE	19	Total	C	N	O	S	0	0
			135	82	23	29	1		
7	AF	23	Total	C	N	O	S	0	0
			158	97	27	33	1		
7	AG	11	Total	C	N	O		0	0
			73	46	13	14			
7	AH	11	Total	C	N	O		0	0
			73	46	13	14			
7	AI	11	Total	C	N	O		0	0
			73	46	13	14			
7	AJ	24	Total	C	N	O	S	0	0
			163	100	28	34	1		
7	AK	25	Total	C	N	O	S	0	0
			169	104	29	35	1		
7	AL	32	Total	C	N	O	S	0	0
			220	134	38	46	2		
7	AM	33	Total	C	N	O	S	0	0
			224	136	39	47	2		
7	AN	33	Total	C	N	O	S	0	0
			224	136	39	47	2		
7	AO	32	Total	C	N	O	S	0	0
			220	134	38	46	2		
7	Dz	148	Total	C	N	O	S	0	0
			1171	719	215	235	2		
7	D1	148	Total	C	N	O	S	0	0
			1171	719	215	235	2		
7	D2	148	Total	C	N	O	S	0	0
			1171	719	215	235	2		
7	D3	148	Total	C	N	O	S	0	0
			1171	719	215	235	2		
7	D4	148	Total	C	N	O	S	0	0
			1171	719	215	235	2		
7	D5	148	Total	C	N	O	S	0	0
			1171	719	215	235	2		
7	EG	148	Total	C	N	O	S	0	0
			1171	719	215	235	2		

Continued on next page...

Continued from previous page...

Mol	Chain	Residues	Atoms					AltConf	Trace
7	EH	148	Total	C	N	O	S	0	0
			1171	719	215	235	2		
7	EI	148	Total	C	N	O	S	0	0
			1171	719	215	235	2		
7	EJ	148	Total	C	N	O	S	0	0
			1171	719	215	235	2		
7	EK	148	Total	C	N	O	S	0	0
			1171	719	215	235	2		
7	EL	148	Total	C	N	O	S	0	0
			1171	719	215	235	2		
7	EM	148	Total	C	N	O	S	0	0
			1171	719	215	235	2		
7	EN	148	Total	C	N	O	S	0	0
			1171	719	215	235	2		
7	EO	148	Total	C	N	O	S	0	0
			1171	719	215	235	2		
7	EP	148	Total	C	N	O	S	0	0
			1171	719	215	235	2		
7	EQ	148	Total	C	N	O	S	0	0
			1171	719	215	235	2		
7	ER	148	Total	C	N	O	S	0	0
			1171	719	215	235	2		
7	ES	148	Total	C	N	O	S	0	0
			1171	719	215	235	2		
7	ET	148	Total	C	N	O	S	0	0
			1171	719	215	235	2		
7	EU	148	Total	C	N	O	S	0	0
			1171	719	215	235	2		
7	EV	148	Total	C	N	O	S	0	0
			1171	719	215	235	2		
7	EW	148	Total	C	N	O	S	0	0
			1171	719	215	235	2		
7	EX	114	Total	C	N	O	S	0	0
			881	543	165	169	4		
7	EY	114	Total	C	N	O	S	0	0
			881	543	165	169	4		
7	EZ	114	Total	C	N	O	S	0	0
			881	543	165	169	4		
7	Ea	114	Total	C	N	O	S	0	0
			881	543	165	169	4		
7	Eb	114	Total	C	N	O	S	0	0
			881	543	165	169	4		

Continued on next page...

Continued from previous page...

Mol	Chain	Residues	Atoms					AltConf	Trace
			Total	C	N	O	S		
7	Ec	109	Total 839	C 515	N 157	O 163	S 4	0	0
7	Ed	114	Total 881	C 543	N 165	O 169	S 4	0	0
7	Ee	114	Total 881	C 543	N 165	O 169	S 4	0	0
7	Ef	114	Total 881	C 543	N 165	O 169	S 4	0	0
7	Eg	94	Total 724	C 446	N 135	O 140	S 3	0	0
7	Eh	103	Total 803	C 496	N 153	O 151	S 3	0	0
7	Ei	103	Total 803	C 496	N 153	O 151	S 3	0	0
7	Ej	103	Total 803	C 496	N 153	O 151	S 3	0	0
7	Ek	85	Total 660	C 405	N 125	O 127	S 3	0	0
7	El	92	Total 704	C 432	N 132	O 137	S 3	0	0
7	Em	91	Total 695	C 427	N 131	O 134	S 3	0	0
7	En	89	Total 684	C 420	N 129	O 132	S 3	0	0
7	Eo	92	Total 704	C 432	N 132	O 137	S 3	0	0
7	Ep	114	Total 881	C 543	N 165	O 169	S 4	0	0
7	Eq	114	Total 881	C 543	N 165	O 169	S 4	0	0
7	Er	114	Total 881	C 543	N 165	O 169	S 4	0	0
7	Es	105	Total 802	C 494	N 147	O 157	S 4	0	0
7	Et	114	Total 881	C 543	N 165	O 169	S 4	0	0
7	Eu	148	Total 1171	C 719	N 215	O 235	S 2	0	0
7	Ev	148	Total 1171	C 719	N 215	O 235	S 2	0	0
7	Ew	148	Total 1171	C 719	N 215	O 235	S 2	0	0

Continued on next page...

Continued from previous page...

Mol	Chain	Residues	Atoms					AltConf	Trace
7	Ex	148	Total	C	N	O	S	0	0
			1171	719	215	235	2		
7	Ey	148	Total	C	N	O	S	0	0
			1171	719	215	235	2		
7	Ez	148	Total	C	N	O	S	0	0
			1171	719	215	235	2		
7	E1	148	Total	C	N	O	S	0	0
			1171	719	215	235	2		
7	E2	148	Total	C	N	O	S	0	0
			1171	719	215	235	2		
7	E3	148	Total	C	N	O	S	0	0
			1171	719	215	235	2		
7	E4	148	Total	C	N	O	S	0	0
			1171	719	215	235	2		
7	E5	148	Total	C	N	O	S	0	0
			1171	719	215	235	2		

- Molecule 8 is a protein called Flagellar basal body rod protein FlgB.

Mol	Chain	Residues	Atoms					AltConf	Trace
8	b	109	Total	C	N	O	S	0	0
			845	523	155	166	1		
8	c	107	Total	C	N	O	S	0	0
			835	518	153	163	1		
8	d	109	Total	C	N	O	S	0	0
			845	523	155	166	1		
8	e	108	Total	C	N	O	S	0	0
			837	519	154	163	1		
8	f	108	Total	C	N	O	S	0	0
			837	519	154	163	1		

- Molecule 9 is a protein called Flagellar basal-body rod protein FlgC.

Mol	Chain	Residues	Atoms					AltConf	Trace
9	g	130	Total	C	N	O	S	0	0
			983	605	168	203	7		
9	h	130	Total	C	N	O	S	0	0
			983	605	168	203	7		
9	i	130	Total	C	N	O	S	0	0
			983	605	168	203	7		
9	j	130	Total	C	N	O	S	0	0
			983	605	168	203	7		

Continued on next page...

Continued from previous page...

Mol	Chain	Residues	Atoms					AltConf	Trace
9	k	130	Total	C	N	O	S	0	0
			983	605	168	203	7		
9	l	130	Total	C	N	O	S	0	0
			983	605	168	203	7		

- Molecule 10 is a protein called Flagellar basal-body rod protein FlgF.

Mol	Chain	Residues	Atoms					AltConf	Trace
10	m	248	Total	C	N	O	S	0	0
			1879	1156	338	373	12		
10	n	248	Total	C	N	O	S	0	0
			1879	1156	338	373	12		
10	o	248	Total	C	N	O	S	0	0
			1879	1156	338	373	12		
10	p	248	Total	C	N	O	S	0	0
			1879	1156	338	373	12		
10	q	248	Total	C	N	O	S	0	0
			1879	1156	338	373	12		

- Molecule 11 is a protein called Flagellar hook-basal body complex protein FlIE.

Mol	Chain	Residues	Atoms					AltConf	Trace
11	r	72	Total	C	N	O	S	0	0
			560	345	99	113	3		
11	s	80	Total	C	N	O	S	0	0
			605	372	108	122	3		
11	t	80	Total	C	N	O	S	0	0
			605	372	108	122	3		
11	u	72	Total	C	N	O	S	0	0
			560	345	99	113	3		
11	v	72	Total	C	N	O	S	0	0
			560	345	99	113	3		
11	w	40	Total	C	N	O	S	0	0
			311	194	53	61	3		

There are 6 discrepancies between the modelled and reference sequences:

Chain	Residue	Modelled	Actual	Comment	Reference
r	3	VAL	ILE	conflict	UNP A0A0H0Y9C1
s	3	VAL	ILE	conflict	UNP A0A0H0Y9C1
t	3	VAL	ILE	conflict	UNP A0A0H0Y9C1
u	3	VAL	ILE	conflict	UNP A0A0H0Y9C1

Continued on next page...

Continued from previous page...

Chain	Residue	Modelled	Actual	Comment	Reference
v	3	VAL	ILE	conflict	UNP A0A0H0Y9C1
w	3	VAL	ILE	conflict	UNP A0A0H0Y9C1

- Molecule 12 is a protein called Flagellar biosynthetic protein FlhB.

Mol	Chain	Residues	Atoms					AltConf	Trace
			Total	C	N	O	S		
12	x	71	552	370	83	95	4	0	0

There is a discrepancy between the modelled and reference sequences:

Chain	Residue	Modelled	Actual	Comment	Reference
x	87	THR	SER	conflict	UNP A0A0H0YB55

- Molecule 13 is a protein called Flagella basal-body protein.

Mol	Chain	Residues	Atoms					AltConf	Trace
			Total	C	N	O	S		
13	B7	352	2774	1735	483	544	12	0	0
13	CB	352	2774	1735	483	544	12	0	0
13	CJ	352	2774	1735	483	544	12	0	0
13	A8	352	2774	1735	483	544	12	0	0
13	CO	352	2774	1735	483	544	12	0	0
13	CT	352	2774	1735	483	544	12	0	0
13	CY	352	2774	1735	483	544	12	0	0
13	Cd	352	2774	1735	483	544	12	0	0
13	Ci	352	2774	1735	483	544	12	0	0
13	Cn	352	2774	1735	483	544	12	0	0
13	Cs	352	2774	1735	483	544	12	0	0
13	Cx	352	2774	1735	483	544	12	0	0

Continued on next page...

Continued from previous page...

Mol	Chain	Residues	Atoms					AltConf	Trace
13	C3	352	Total	C	N	O	S	0	0
			2774	1735	483	544	12		
13	C8	352	Total	C	N	O	S	0	0
			2774	1735	483	544	12		
13	B1	352	Total	C	N	O	S	0	0
			2774	1735	483	544	12		
13	B6	352	Total	C	N	O	S	0	0
			2774	1735	483	544	12		
13	BC	352	Total	C	N	O	S	0	0
			2774	1735	483	544	12		
13	BH	352	Total	C	N	O	S	0	0
			2774	1735	483	544	12		
13	BM	352	Total	C	N	O	S	0	0
			2774	1735	483	544	12		
13	BR	352	Total	C	N	O	S	0	0
			2774	1735	483	544	12		
13	BW	352	Total	C	N	O	S	0	0
			2774	1735	483	544	12		
13	Bb	352	Total	C	N	O	S	0	0
			2774	1735	483	544	12		
13	Bg	352	Total	C	N	O	S	0	0
			2774	1735	483	544	12		
13	Bl	352	Total	C	N	O	S	0	0
			2774	1735	483	544	12		
13	Bq	352	Total	C	N	O	S	0	0
			2774	1735	483	544	12		
13	Bv	352	Total	C	N	O	S	0	0
			2774	1735	483	544	12		

- Molecule 14 is a protein called FlgH.

Mol	Chain	Residues	Atoms					AltConf	Trace
14	B8	221	Total	C	N	O	S	0	0
			1678	1038	288	349	3		
14	CC	221	Total	C	N	O	S	0	0
			1678	1038	288	349	3		
14	A4	221	Total	C	N	O	S	0	0
			1678	1038	288	349	3		
14	A9	221	Total	C	N	O	S	0	0
			1678	1038	288	349	3		
14	CK	221	Total	C	N	O	S	0	0
			1678	1038	288	349	3		

Continued on next page...

Continued from previous page...

Mol	Chain	Residues	Atoms					AltConf	Trace
			Total	C	N	O	S		
14	CP	221	Total 1678	C 1038	N 288	O 349	S 3	0	0
14	CU	221	Total 1678	C 1038	N 288	O 349	S 3	0	0
14	CZ	221	Total 1678	C 1038	N 288	O 349	S 3	0	0
14	Ce	221	Total 1678	C 1038	N 288	O 349	S 3	0	0
14	Cj	221	Total 1678	C 1038	N 288	O 349	S 3	0	0
14	Co	221	Total 1678	C 1038	N 288	O 349	S 3	0	0
14	Ct	221	Total 1678	C 1038	N 288	O 349	S 3	0	0
14	Cy	221	Total 1678	C 1038	N 288	O 349	S 3	0	0
14	C4	221	Total 1678	C 1038	N 288	O 349	S 3	0	0
14	C9	221	Total 1678	C 1038	N 288	O 349	S 3	0	0
14	B2	221	Total 1678	C 1038	N 288	O 349	S 3	0	0
14	BD	221	Total 1678	C 1038	N 288	O 349	S 3	0	0
14	BI	221	Total 1678	C 1038	N 288	O 349	S 3	0	0
14	BN	221	Total 1678	C 1038	N 288	O 349	S 3	0	0
14	BS	221	Total 1678	C 1038	N 288	O 349	S 3	0	0
14	BX	221	Total 1678	C 1038	N 288	O 349	S 3	0	0
14	Bc	221	Total 1678	C 1038	N 288	O 349	S 3	0	0
14	Bh	221	Total 1678	C 1038	N 288	O 349	S 3	0	0
14	Bm	221	Total 1678	C 1038	N 288	O 349	S 3	0	0
14	Br	221	Total 1678	C 1038	N 288	O 349	S 3	0	0
14	Bw	221	Total 1678	C 1038	N 288	O 349	S 3	0	0

- Molecule 15 is a protein called Flagellar assembly lipoprotein FlgP.

Mol	Chain	Residues	Atoms				AltConf	Trace
			Total	C	N	O		
15	B9	11	97	61	18	18	0	0
15	CD	11	97	61	18	18	0	0
15	A0	11	97	61	18	18	0	0
15	A5	11	97	61	18	18	0	0
15	CL	11	97	61	18	18	0	0
15	CQ	11	97	61	18	18	0	0
15	CV	11	97	61	18	18	0	0
15	Ca	11	97	61	18	18	0	0
15	Cf	11	97	61	18	18	0	0
15	Ck	11	97	61	18	18	0	0
15	Cp	11	97	61	18	18	0	0
15	Cu	11	97	61	18	18	0	0
15	Cz	11	97	61	18	18	0	0
15	C5	11	97	61	18	18	0	0
15	C0	11	97	61	18	18	0	0
15	B3	11	97	61	18	18	0	0
15	BE	11	97	61	18	18	0	0
15	BJ	11	97	61	18	18	0	0
15	BO	11	97	61	18	18	0	0
15	BT	11	97	61	18	18	0	0
15	BY	11	97	61	18	18	0	0

Continued on next page...

Continued from previous page...

Mol	Chain	Residues	Atoms				AltConf	Trace
			Total	C	N	O		
15	Bd	11	97	61	18	18	0	0
15	Bi	11	97	61	18	18	0	0
15	Bn	11	97	61	18	18	0	0
15	Bs	11	97	61	18	18	0	0
15	Bx	11	97	61	18	18	0	0

- Molecule 16 is a protein called FlgH.

Mol	Chain	Residues	Atoms				AltConf	Trace
			Total	C	N	O		
16	B0	13	65	39	13	13	0	0
16	CE	13	65	39	13	13	0	0
16	CH	13	65	39	13	13	0	0
16	A6	13	65	39	13	13	0	0
16	CM	13	65	39	13	13	0	0
16	CR	13	65	39	13	13	0	0
16	CW	13	65	39	13	13	0	0
16	Cb	13	65	39	13	13	0	0
16	Cg	13	65	39	13	13	0	0
16	Cl	13	65	39	13	13	0	0
16	Cq	13	65	39	13	13	0	0
16	Cv	13	65	39	13	13	0	0
16	C1	13	65	39	13	13	0	0
16	C6	13	65	39	13	13	0	0

Continued on next page...

Continued from previous page...

Mol	Chain	Residues	Atoms				AltConf	Trace
			Total	C	N	O		
16	B4	13	65	39	13	13	0	0
16	BA	13	65	39	13	13	0	0
16	BF	13	65	39	13	13	0	0
16	BK	13	65	39	13	13	0	0
16	BP	13	65	39	13	13	0	0
16	BU	13	65	39	13	13	0	0
16	BZ	13	65	39	13	13	0	0
16	Be	13	65	39	13	13	0	0
16	Bj	13	65	39	13	13	0	0
16	Bo	13	65	39	13	13	0	0
16	Bt	13	65	39	13	13	0	0
16	By	13	65	39	13	13	0	0
16	D0	13	65	39	13	13	0	0

- Molecule 17 is a protein called FlgI.

Mol	Chain	Residues	Atoms					AltConf	Trace
			Total	C	N	O	S		
17	CA	287	2102	1324	371	400	7	0	0
17	CF	287	2102	1324	371	400	7	0	0
17	CI	287	2102	1324	371	400	7	0	0
17	A7	287	2102	1324	371	400	7	0	0
17	CN	287	2102	1324	371	400	7	0	0
17	CS	287	2102	1324	371	400	7	0	0

Continued on next page...

Continued from previous page...

Mol	Chain	Residues	Atoms					AltConf	Trace
			Total	C	N	O	S		
17	CX	287	Total 2102	C 1324	N 371	O 400	S 7	0	0
17	Cc	287	Total 2102	C 1324	N 371	O 400	S 7	0	0
17	Ch	287	Total 2102	C 1324	N 371	O 400	S 7	0	0
17	Cm	287	Total 2102	C 1324	N 371	O 400	S 7	0	0
17	Cr	287	Total 2102	C 1324	N 371	O 400	S 7	0	0
17	Cw	287	Total 2102	C 1324	N 371	O 400	S 7	0	0
17	C2	287	Total 2102	C 1324	N 371	O 400	S 7	0	0
17	C7	287	Total 2102	C 1324	N 371	O 400	S 7	0	0
17	B5	287	Total 2102	C 1324	N 371	O 400	S 7	0	0
17	BB	287	Total 2102	C 1324	N 371	O 400	S 7	0	0
17	BG	287	Total 2102	C 1324	N 371	O 400	S 7	0	0
17	BL	287	Total 2102	C 1324	N 371	O 400	S 7	0	0
17	BQ	287	Total 2102	C 1324	N 371	O 400	S 7	0	0
17	BV	287	Total 2102	C 1324	N 371	O 400	S 7	0	0
17	Ba	287	Total 2102	C 1324	N 371	O 400	S 7	0	0
17	Bf	287	Total 2102	C 1324	N 371	O 400	S 7	0	0
17	Bk	287	Total 2102	C 1324	N 371	O 400	S 7	0	0
17	Bp	287	Total 2102	C 1324	N 371	O 400	S 7	0	0
17	Bu	287	Total 2102	C 1324	N 371	O 400	S 7	0	0
17	Bz	287	Total 2102	C 1324	N 371	O 400	S 7	0	0

- Molecule 18 is a protein called Component of sodium-driven polar flagellar motor.

Mol	Chain	Residues	Atoms					AltConf	Trace
18	CG	270	Total 2183	C 1372	N 394	O 410	S 7	0	0
18	DA	271	Total 2190	C 1377	N 395	O 411	S 7	0	0
18	DD	270	Total 2183	C 1372	N 394	O 410	S 7	0	0
18	DE	271	Total 2190	C 1377	N 395	O 411	S 7	0	0
18	DH	270	Total 2183	C 1372	N 394	O 410	S 7	0	0
18	DI	271	Total 2190	C 1377	N 395	O 411	S 7	0	0
18	DL	270	Total 2183	C 1372	N 394	O 410	S 7	0	0
18	DM	271	Total 2190	C 1377	N 395	O 411	S 7	0	0
18	DP	270	Total 2183	C 1372	N 394	O 410	S 7	0	0
18	DQ	271	Total 2190	C 1377	N 395	O 411	S 7	0	0
18	DT	270	Total 2183	C 1372	N 394	O 410	S 7	0	0
18	DU	271	Total 2190	C 1377	N 395	O 411	S 7	0	0
18	DX	270	Total 2183	C 1372	N 394	O 410	S 7	0	0
18	DY	271	Total 2190	C 1377	N 395	O 411	S 7	0	0
18	Db	270	Total 2183	C 1372	N 394	O 410	S 7	0	0
18	Dc	271	Total 2190	C 1377	N 395	O 411	S 7	0	0
18	Df	270	Total 2183	C 1372	N 394	O 410	S 7	0	0
18	Dg	271	Total 2190	C 1377	N 395	O 411	S 7	0	0
18	Dj	270	Total 2183	C 1372	N 394	O 410	S 7	0	0
18	Dk	271	Total 2190	C 1377	N 395	O 411	S 7	0	0
18	Dn	270	Total 2183	C 1372	N 394	O 410	S 7	0	0
18	Do	271	Total 2190	C 1377	N 395	O 411	S 7	0	0

Continued on next page...

Continued from previous page...

Mol	Chain	Residues	Atoms					AltConf	Trace
			Total	C	N	O	S		
18	Dr	270	Total 2183	C 1372	N 394	O 410	S 7	0	0
18	Ds	271	Total 2190	C 1377	N 395	O 411	S 7	0	0
18	Dv	270	Total 2183	C 1372	N 394	O 410	S 7	0	0
18	Dw	271	Total 2190	C 1377	N 395	O 411	S 7	0	0

- Molecule 19 is a protein called Sodium-type flagellar motor component.

Mol	Chain	Residues	Atoms					AltConf	Trace
			Total	C	N	O	S		
19	DB	179	Total 1471	C 927	N 270	O 269	S 5	0	0
19	DC	179	Total 1471	C 927	N 270	O 269	S 5	0	0
19	DF	179	Total 1471	C 927	N 270	O 269	S 5	0	0
19	DG	179	Total 1471	C 927	N 270	O 269	S 5	0	0
19	DJ	179	Total 1471	C 927	N 270	O 269	S 5	0	0
19	DK	179	Total 1471	C 927	N 270	O 269	S 5	0	0
19	DN	179	Total 1471	C 927	N 270	O 269	S 5	0	0
19	DO	179	Total 1471	C 927	N 270	O 269	S 5	0	0
19	DR	179	Total 1471	C 927	N 270	O 269	S 5	0	0
19	DS	179	Total 1471	C 927	N 270	O 269	S 5	0	0
19	DV	179	Total 1471	C 927	N 270	O 269	S 5	0	0
19	DW	179	Total 1471	C 927	N 270	O 269	S 5	0	0
19	DZ	179	Total 1471	C 927	N 270	O 269	S 5	0	0
19	Da	179	Total 1471	C 927	N 270	O 269	S 5	0	0
19	Dd	179	Total 1471	C 927	N 270	O 269	S 5	0	0

Continued on next page...

Continued from previous page...

Mol	Chain	Residues	Atoms					AltConf	Trace
19	De	179	Total	C	N	O	S	0	0
			1471	927	270	269	5		
19	Dh	179	Total	C	N	O	S	0	0
			1471	927	270	269	5		
19	Di	179	Total	C	N	O	S	0	0
			1471	927	270	269	5		
19	Dl	179	Total	C	N	O	S	0	0
			1471	927	270	269	5		
19	Dm	179	Total	C	N	O	S	0	0
			1471	927	270	269	5		
19	Dp	179	Total	C	N	O	S	0	0
			1471	927	270	269	5		
19	Dq	179	Total	C	N	O	S	0	0
			1471	927	270	269	5		
19	Dt	179	Total	C	N	O	S	0	0
			1471	927	270	269	5		
19	Du	179	Total	C	N	O	S	0	0
			1471	927	270	269	5		
19	Dx	179	Total	C	N	O	S	0	0
			1471	927	270	269	5		
19	Dy	179	Total	C	N	O	S	0	0
			1471	927	270	269	5		

- Molecule 20 is a protein called FlgB-Dc.

Mol	Chain	Residues	Atoms				AltConf	Trace
20	D6	12	Total	C	N	O	0	0
			58	34	12	12		
20	D7	9	Total	C	N	O	0	0
			43	25	9	9		
20	D8	10	Total	C	N	O	0	0
			48	28	10	10		
20	D9	10	Total	C	N	O	0	0
			48	28	10	10		

- Molecule 21 is a protein called FliE-helix 1.

Mol	Chain	Residues	Atoms				AltConf	Trace
21	EA	17	Total	C	N	O	0	0
			84	50	17	17		
21	EB	17	Total	C	N	O	0	0
			84	50	17	17		

Continued on next page...

Continued from previous page...

Mol	Chain	Residues	Atoms				AltConf	Trace
			Total	C	N	O		
21	EC	17	84	50	17	17	0	0
21	ED	17	84	50	17	17	0	0
21	EE	17	84	50	17	17	0	0
21	EF	17	84	50	17	17	0	0

- Molecule 22 is (1S)-2-{{[(2R)-2,3-DIHYDROXYPROPYL]OXY}(HYDROXY)PHOSPHORYL]OXY}-1-[(PALMITOYL)OXY]METHYL]ETHYL STEARATE (CCD ID: PGT) (formula: C₄₀H₇₉O₁₀P) (labeled as "Ligand of Interest" by depositor).

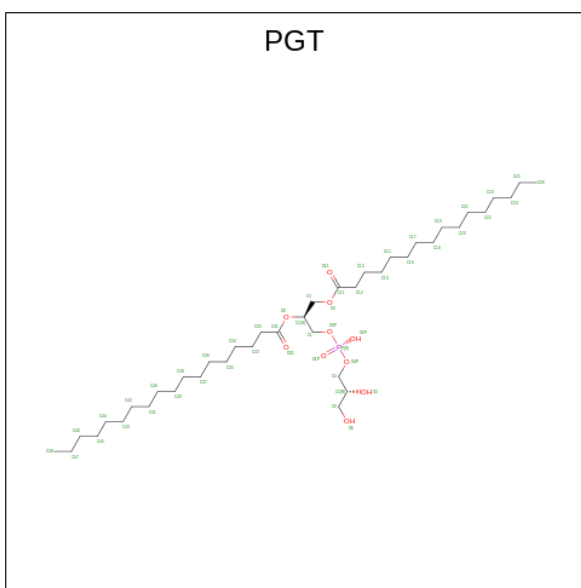

Mol	Chain	Residues	Atoms				AltConf
			Total	C	O	P	
22	2	1	51	40	10	1	0
22	e	1	51	40	10	1	0
22	t	1	51	40	10	1	0
22	v	1	51	40	10	1	0

- Molecule 23 is (11R,14S)-17-amino-14-hydroxy-8,14-dioxo-9,13,15-trioxa-14lambda 5 -phosphaheptadecan-11-yl decanoate (CCD ID: XKP) (formula: C₂₃H₄₆NO₈P) (labeled as "Ligand of Interest" by depositor).

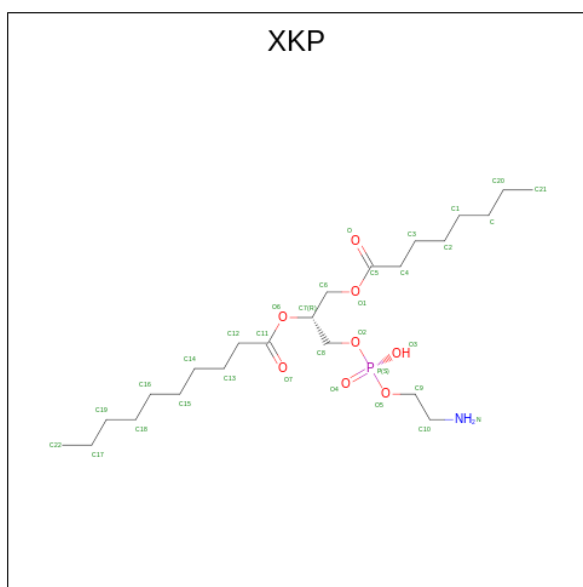

Mol	Chain	Residues	Atoms					AltConf
			Total	C	N	O	P	
23	e	1	Total	C	N	O	P	0
			32	22	1	8	1	
23	s	1	Total	C	N	O	P	0
			32	22	1	8	1	
23	t	1	Total	C	N	O	P	0
			32	22	1	8	1	
23	u	1	Total	C	N	O	P	0
			32	22	1	8	1	
23	v	1	Total	C	N	O	P	0
			32	22	1	8	1	

3 Residue-property plots [i](#)

These plots are drawn for all protein, RNA, DNA and oligosaccharide chains in the entry. The first graphic for a chain summarises the proportions of the various outlier classes displayed in the second graphic. The second graphic shows the sequence view annotated by issues in geometry and atom inclusion in map density. Residues are color-coded according to the number of geometric quality criteria for which they contain at least one outlier: green = 0, yellow = 1, orange = 2 and red = 3 or more. A red diamond above a residue indicates a poor fit to the EM map for this residue (all-atom inclusion < 40%). Stretches of 2 or more consecutive residues without any outlier are shown as a green connector. Residues present in the sample, but not in the model, are shown in grey.

- Molecule 1: LRR

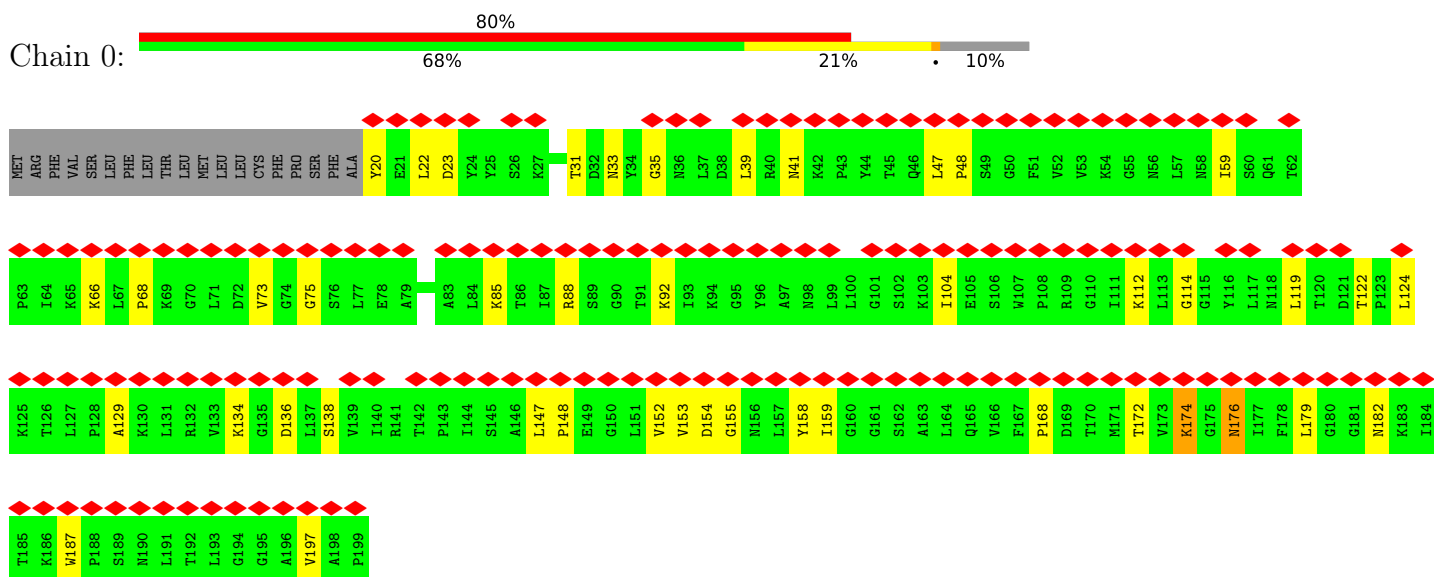

- Molecule 1: LRR

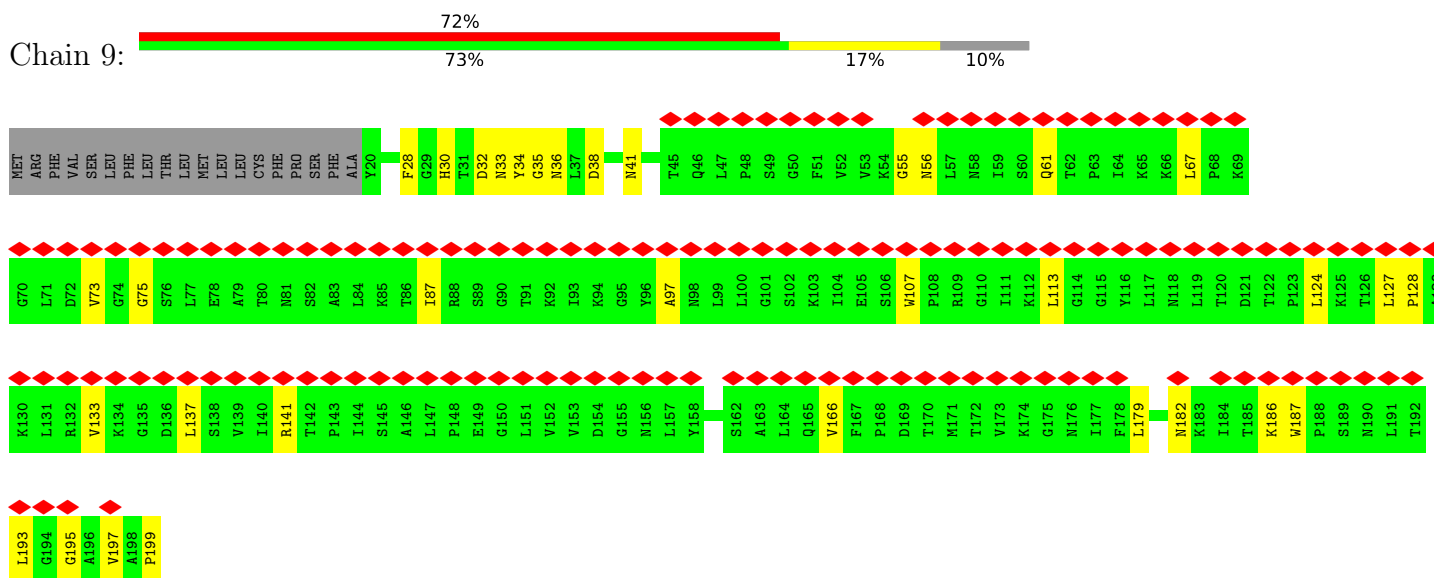

- Molecule 2: Flagellar biosynthetic protein FlIP

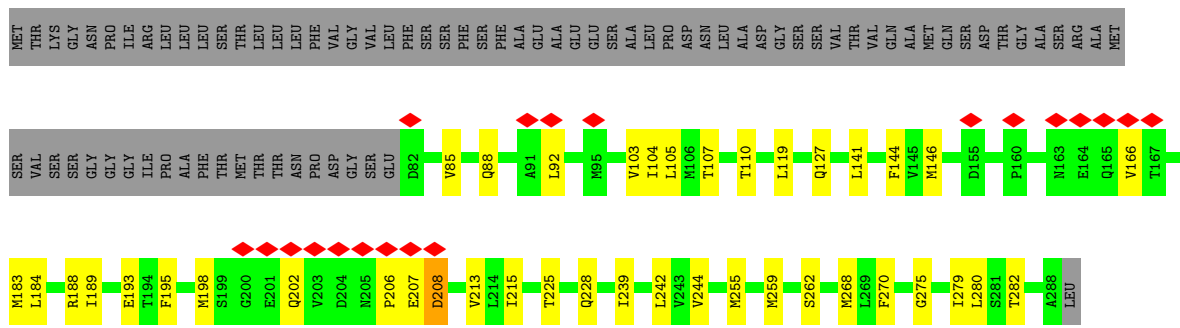

• Molecule 2: Flagellar biosynthetic protein FliP

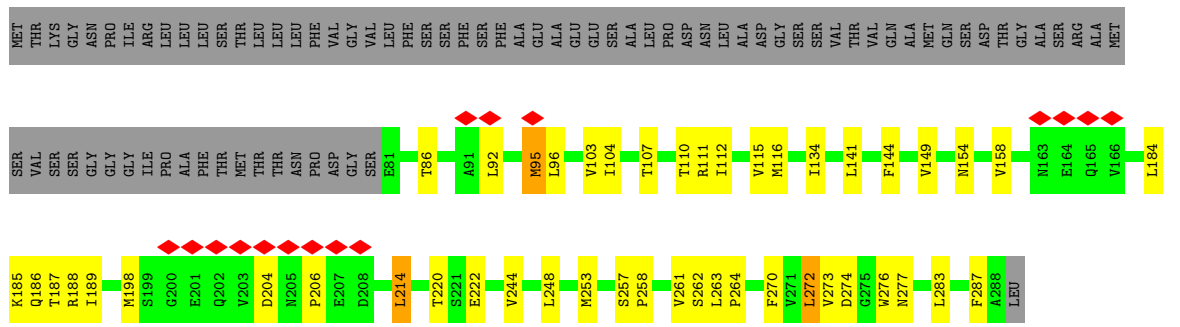

• Molecule 2: Flagellar biosynthetic protein FliP

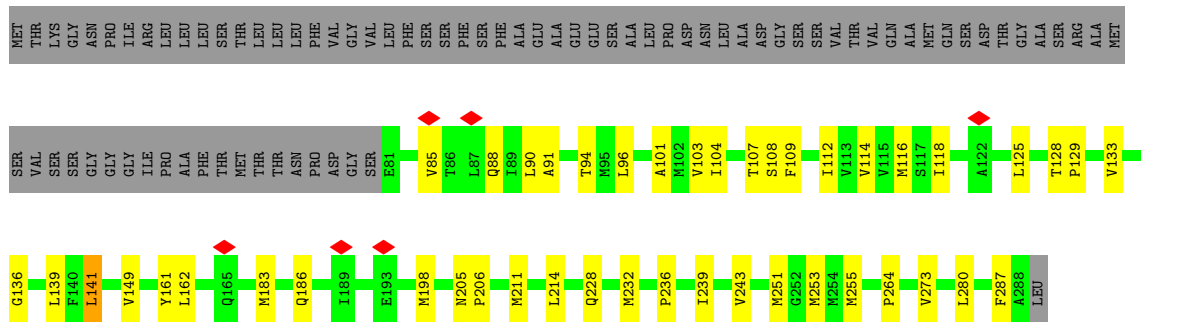

• Molecule 2: Flagellar biosynthetic protein FliP

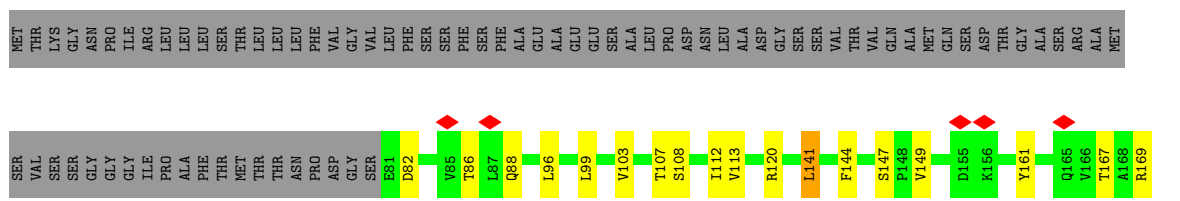

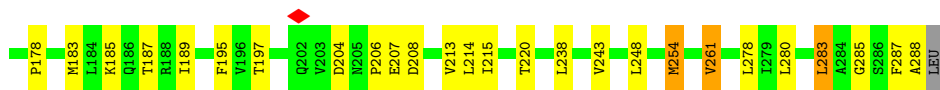

• Molecule 2: Flagellar biosynthetic protein FliP

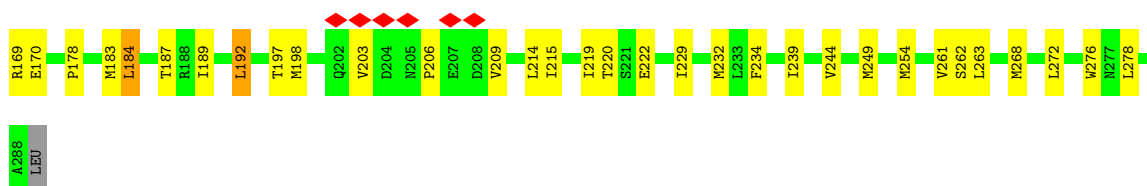
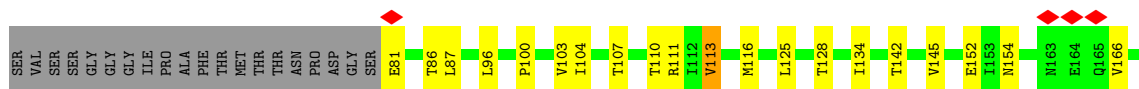
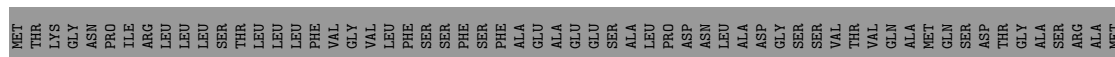

• Molecule 3: Flagellar biosynthetic protein FliQ



• Molecule 3: Flagellar biosynthetic protein FliQ



• Molecule 3: Flagellar biosynthetic protein FliQ



• Molecule 3: Flagellar biosynthetic protein FliQ

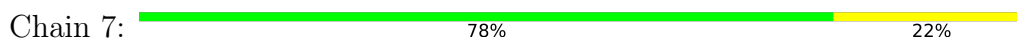

• Molecule 4: Flagellar biosynthetic protein FliR

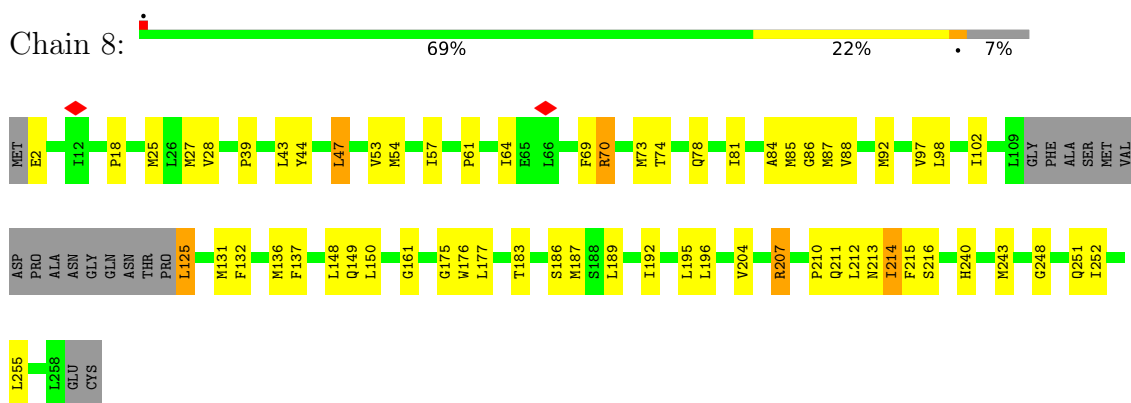

• Molecule 5: Flagellar basal-body rod protein FlgG

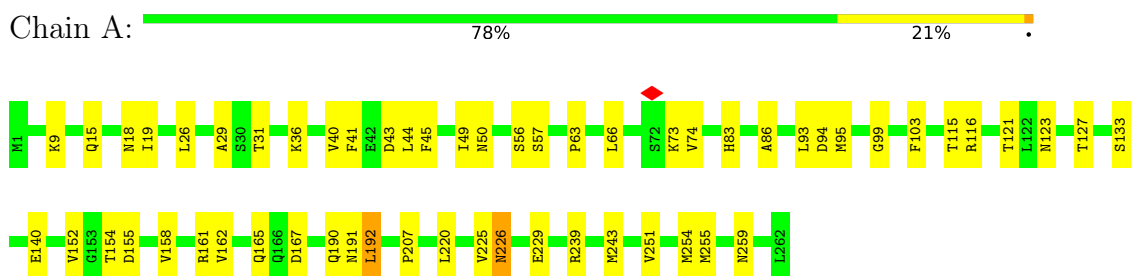

• Molecule 5: Flagellar basal-body rod protein FlgG

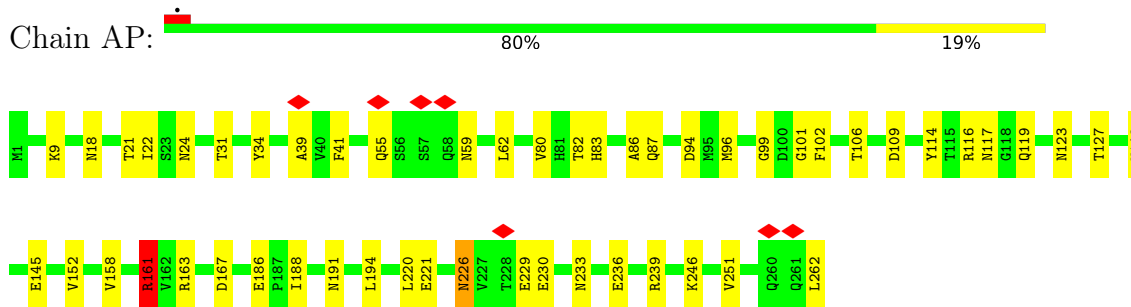

• Molecule 5: Flagellar basal-body rod protein FlgG

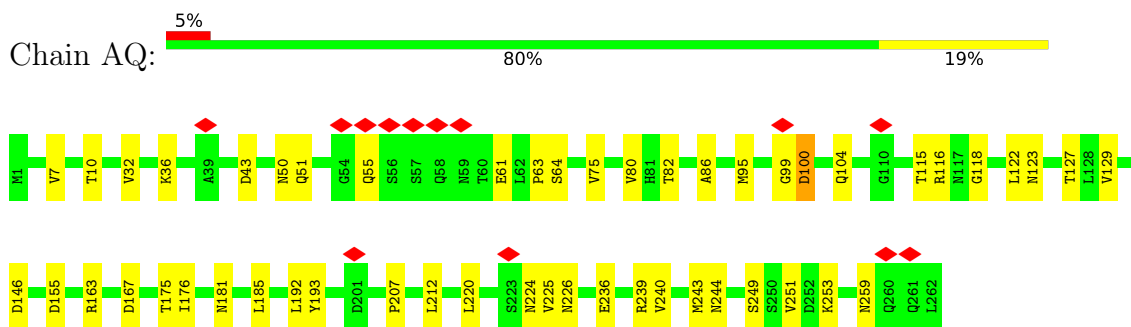

• Molecule 5: Flagellar basal-body rod protein FlgG



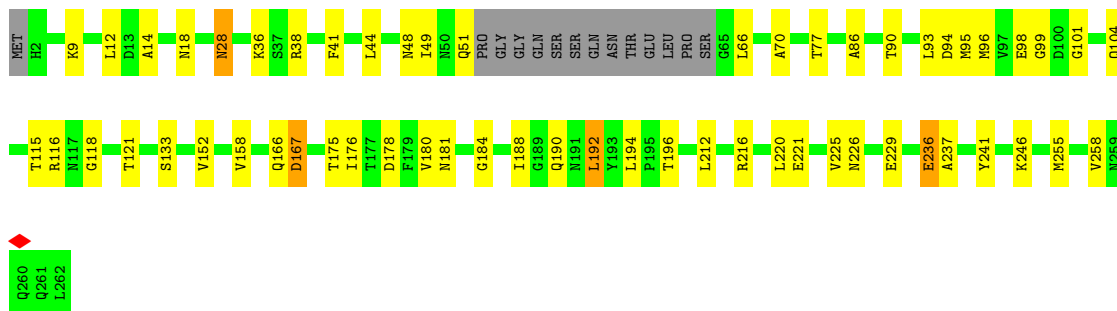

• Molecule 5: Flagellar basal-body rod protein FlgG

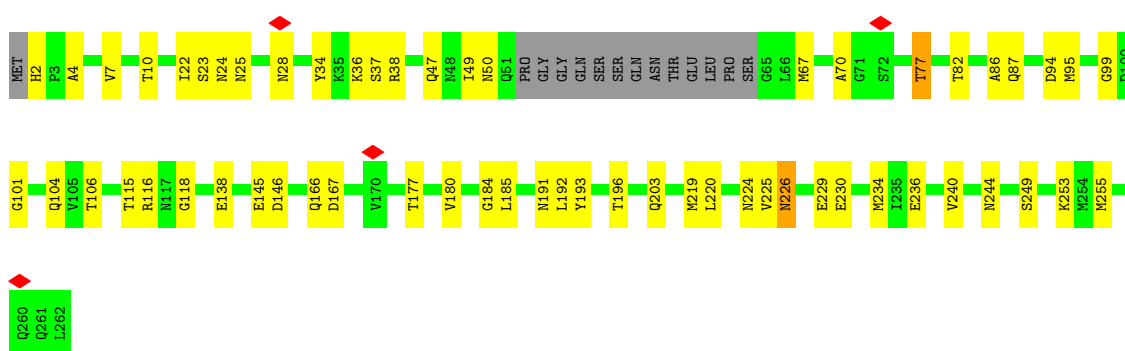

• Molecule 5: Flagellar basal-body rod protein FlgG

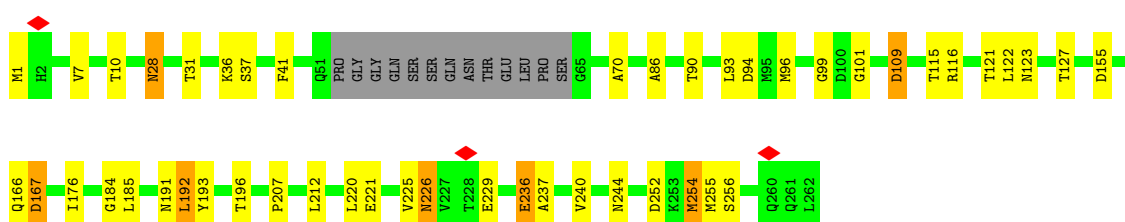
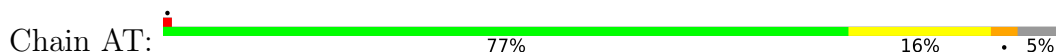

• Molecule 5: Flagellar basal-body rod protein FlgG

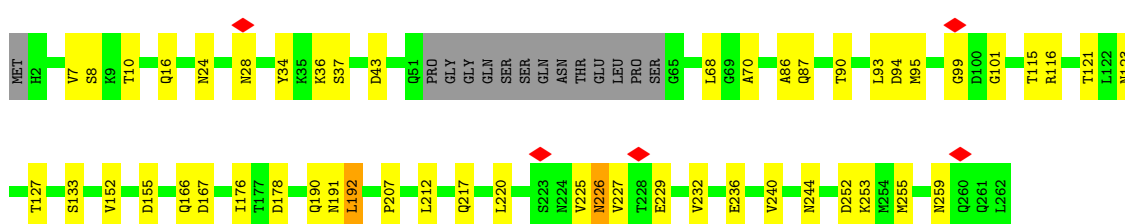
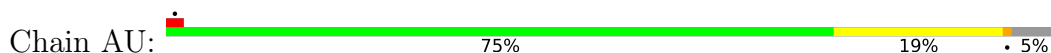

• Molecule 5: Flagellar basal-body rod protein FlgG

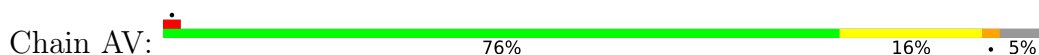

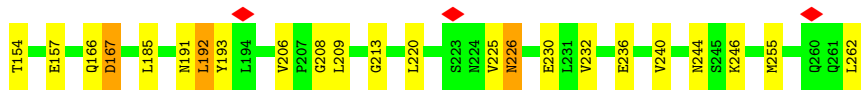
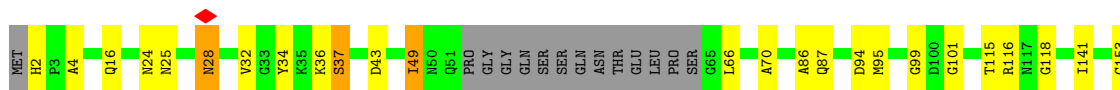

• Molecule 5: Flagellar basal-body rod protein FlgG

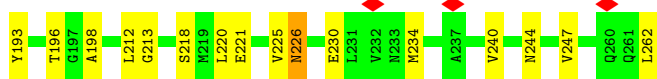
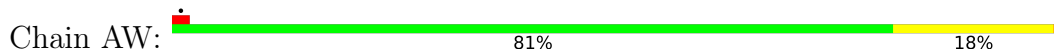

• Molecule 5: Flagellar basal-body rod protein FlgG

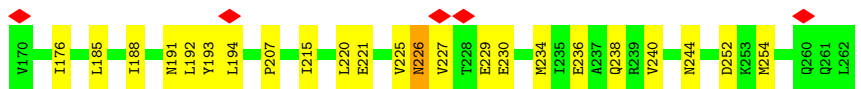
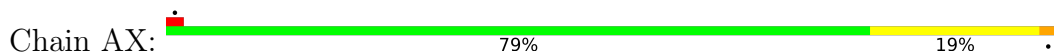

• Molecule 5: Flagellar basal-body rod protein FlgG

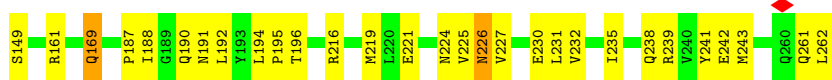
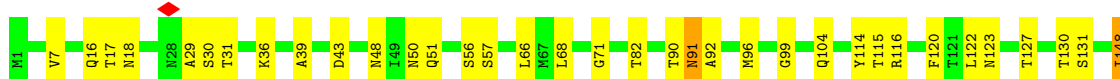
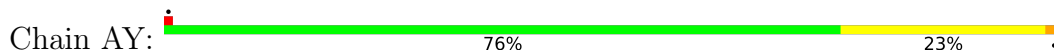

• Molecule 5: Flagellar basal-body rod protein FlgG



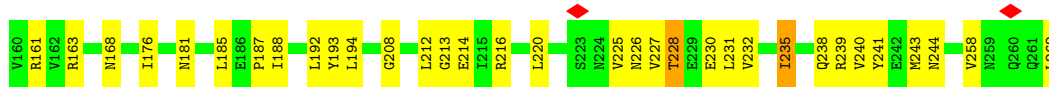

• Molecule 5: Flagellar basal-body rod protein FlgG

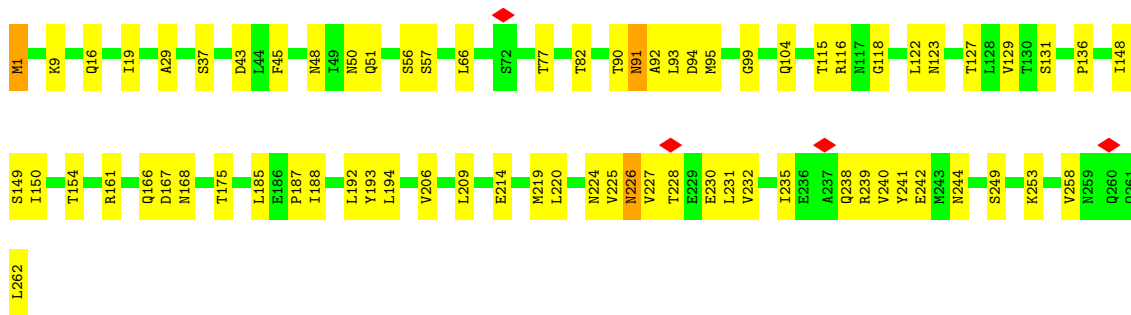
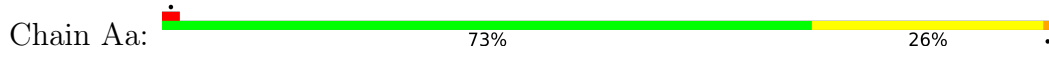

• Molecule 5: Flagellar basal-body rod protein FlgG

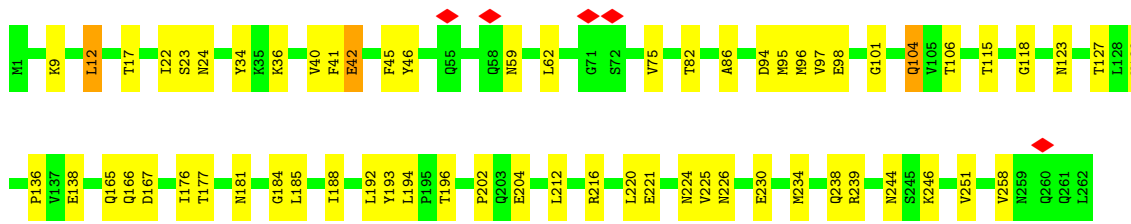
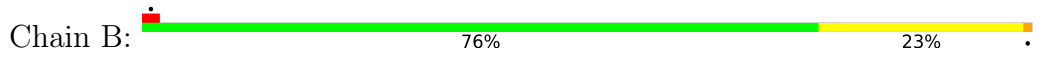

• Molecule 5: Flagellar basal-body rod protein FlgG

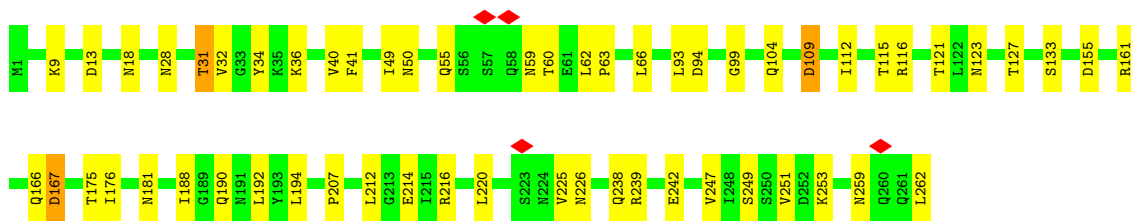
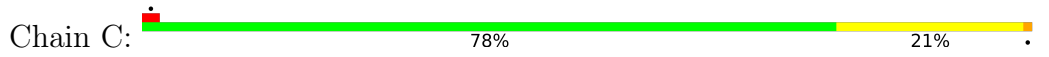

• Molecule 5: Flagellar basal-body rod protein FlgG

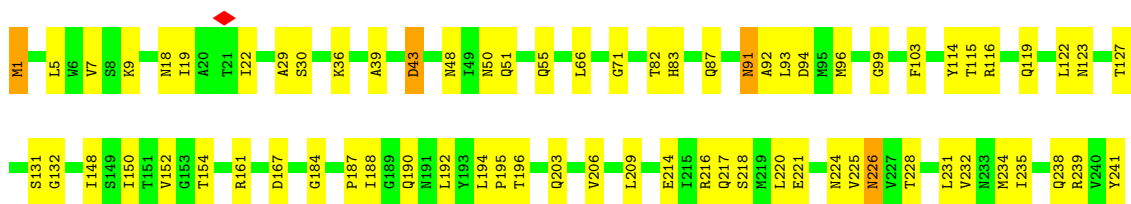

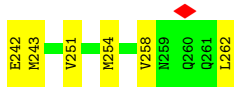

• Molecule 5: Flagellar basal-body rod protein FlgG

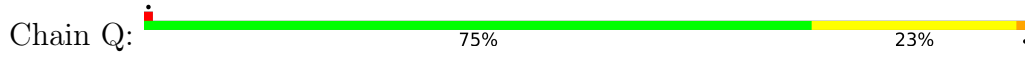

• Molecule 5: Flagellar basal-body rod protein FlgG

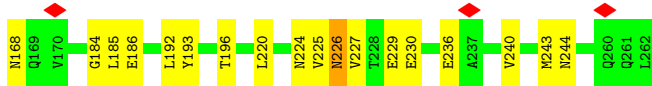
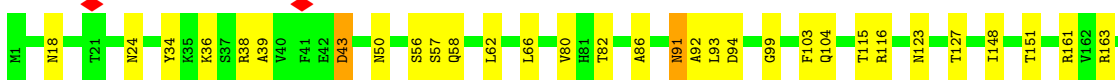
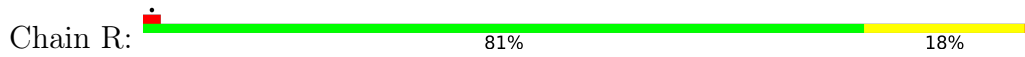

• Molecule 5: Flagellar basal-body rod protein FlgG

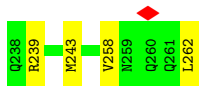

• Molecule 5: Flagellar basal-body rod protein FlgG

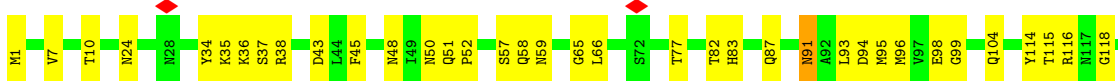

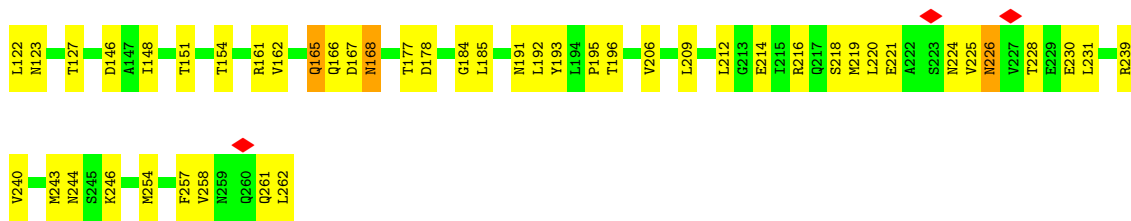

• Molecule 5: Flagellar basal-body rod protein FlgG

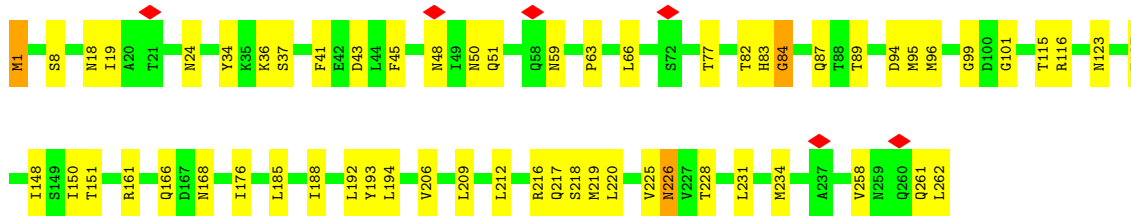
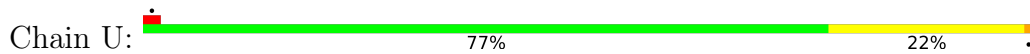

• Molecule 5: Flagellar basal-body rod protein FlgG

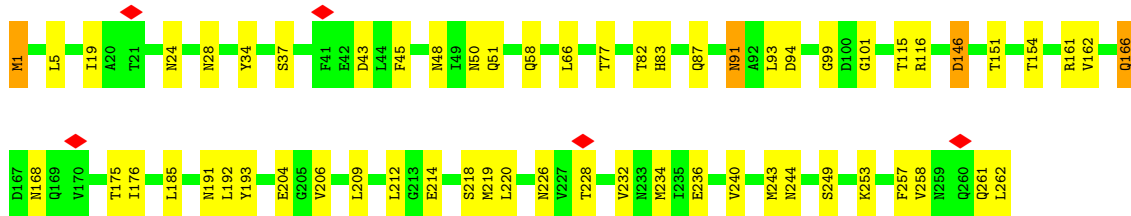
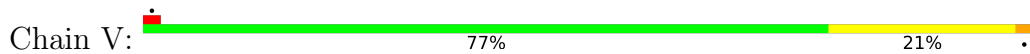

• Molecule 5: Flagellar basal-body rod protein FlgG

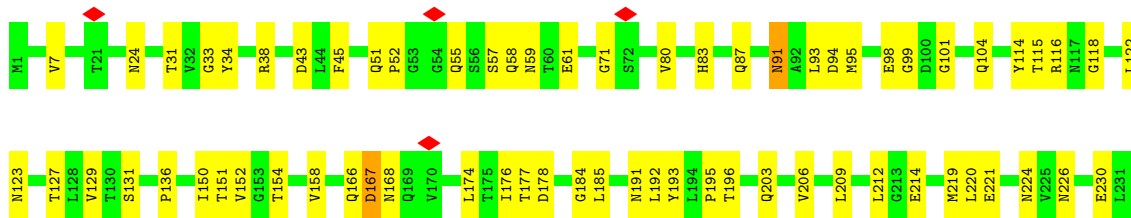

• Molecule 5: Flagellar basal-body rod protein FlgG

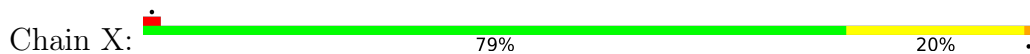

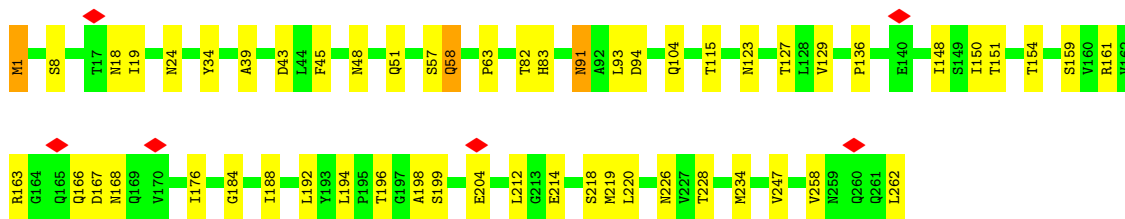

• Molecule 5: Flagellar basal-body rod protein FlgG

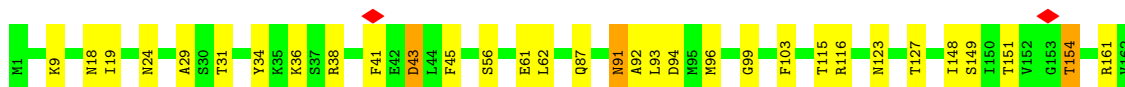
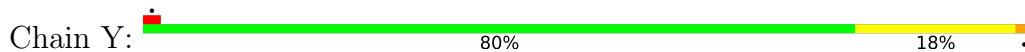

• Molecule 5: Flagellar basal-body rod protein FlgG

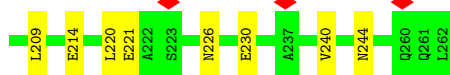

• Molecule 5: Flagellar basal-body rod protein FlgG

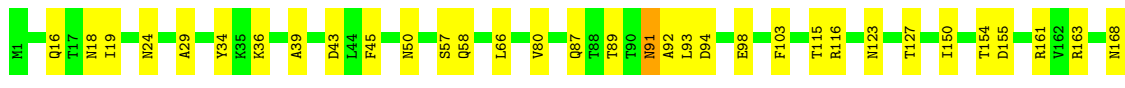
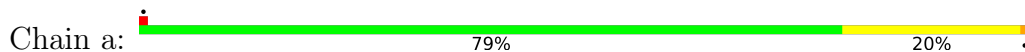

• Molecule 6: Flagellar hook protein FlgE

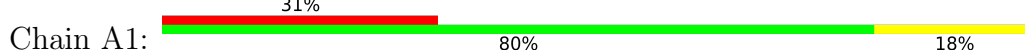

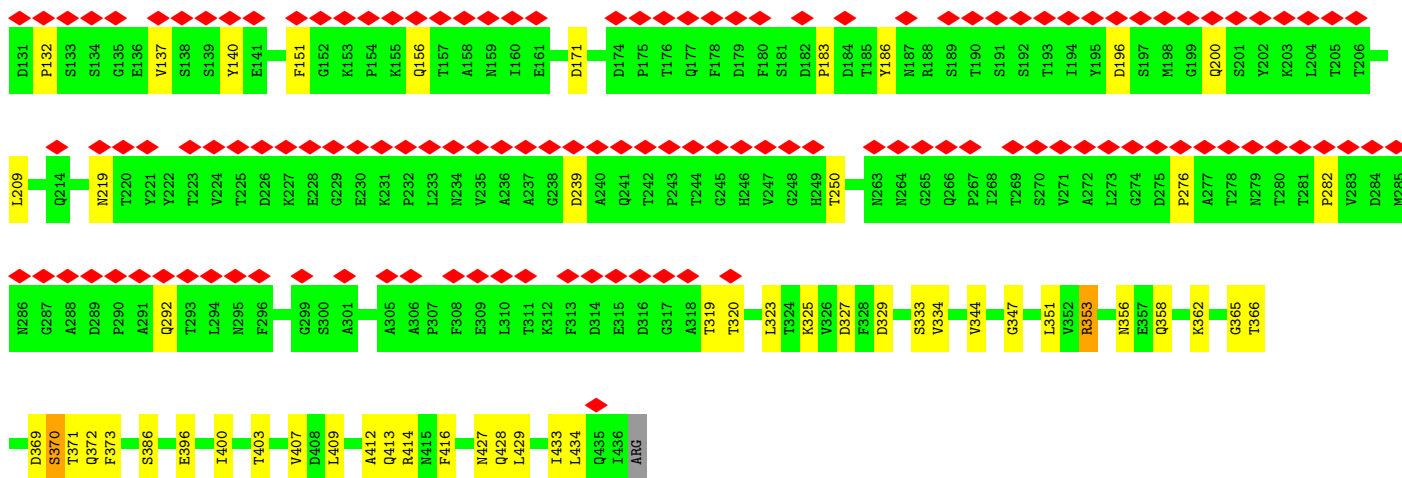

• Molecule 6: Flagellar hook protein FlgE

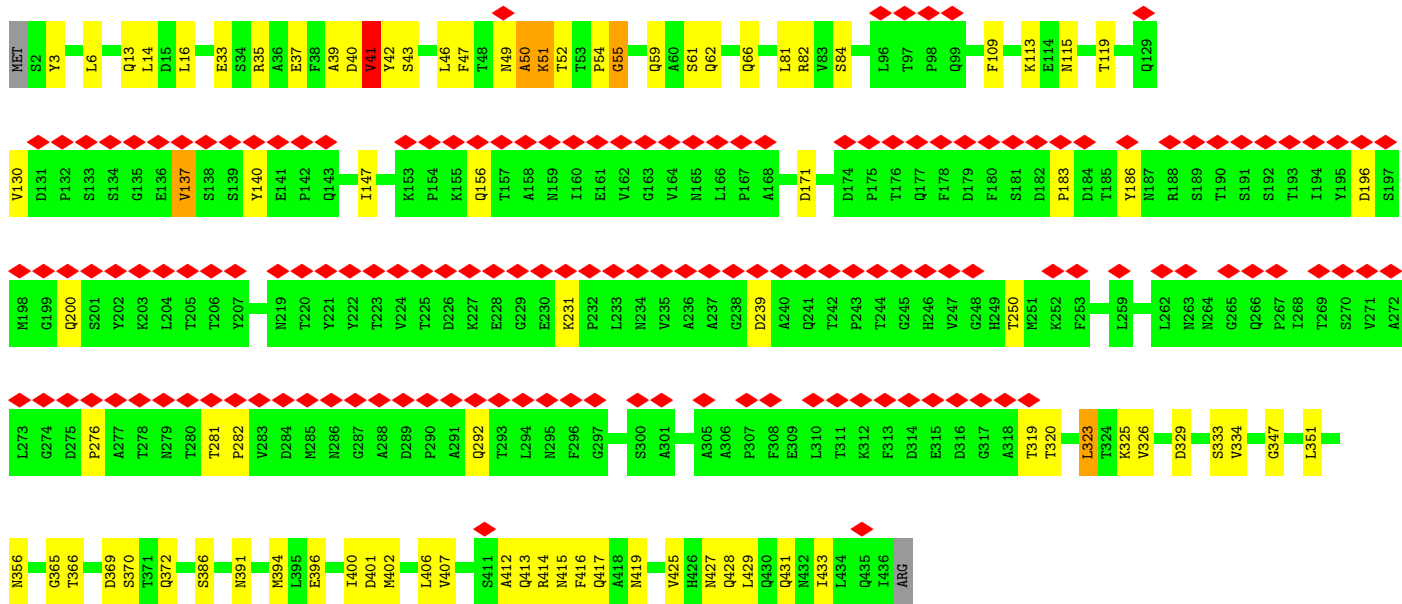
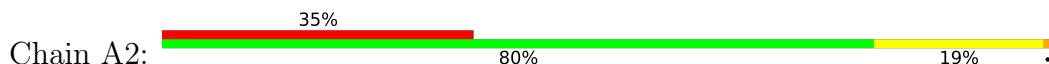

• Molecule 6: Flagellar hook protein FlgE

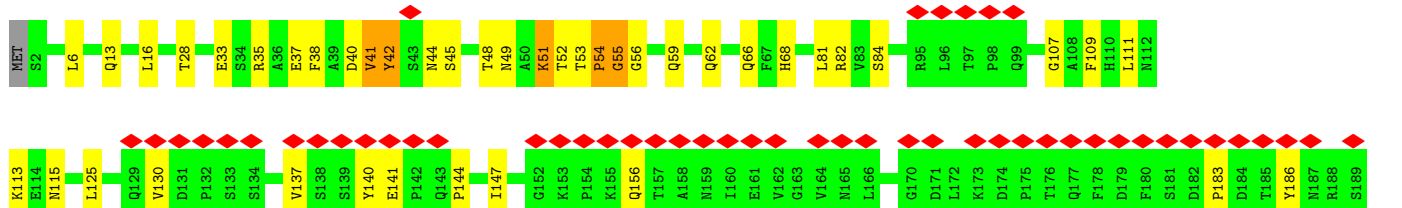
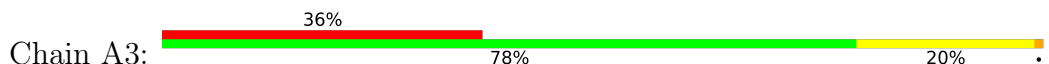

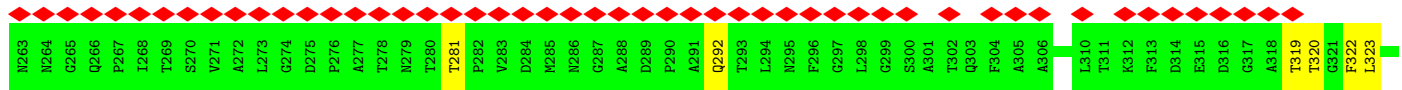
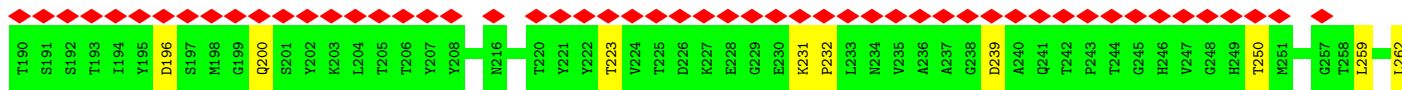

• Molecule 6: Flagellar hook protein FlgE

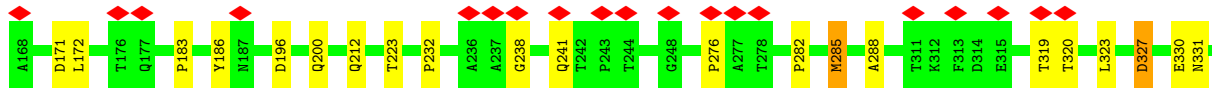
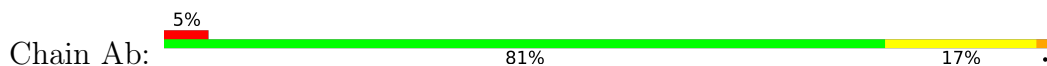

• Molecule 6: Flagellar hook protein FlgE

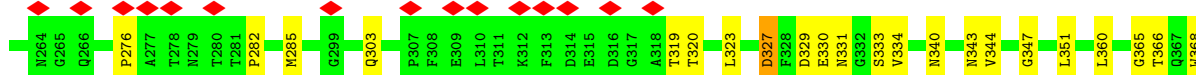
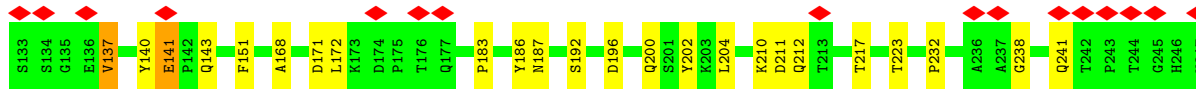
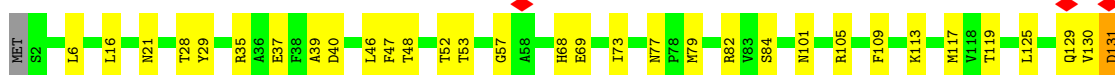
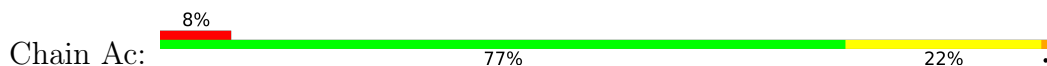

• Molecule 6: Flagellar hook protein FlgE

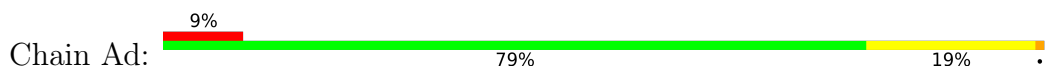

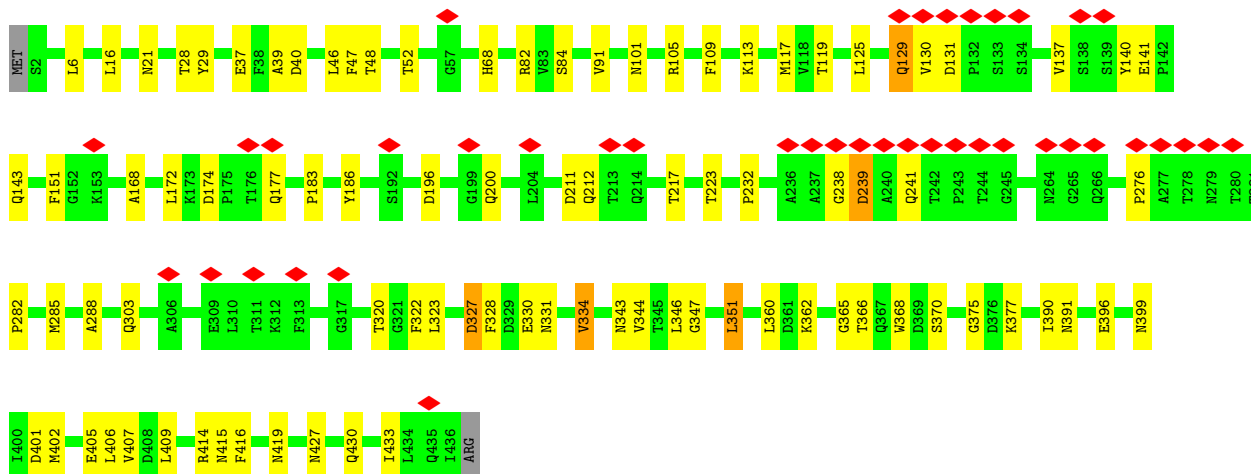

• Molecule 6: Flagellar hook protein FlgE

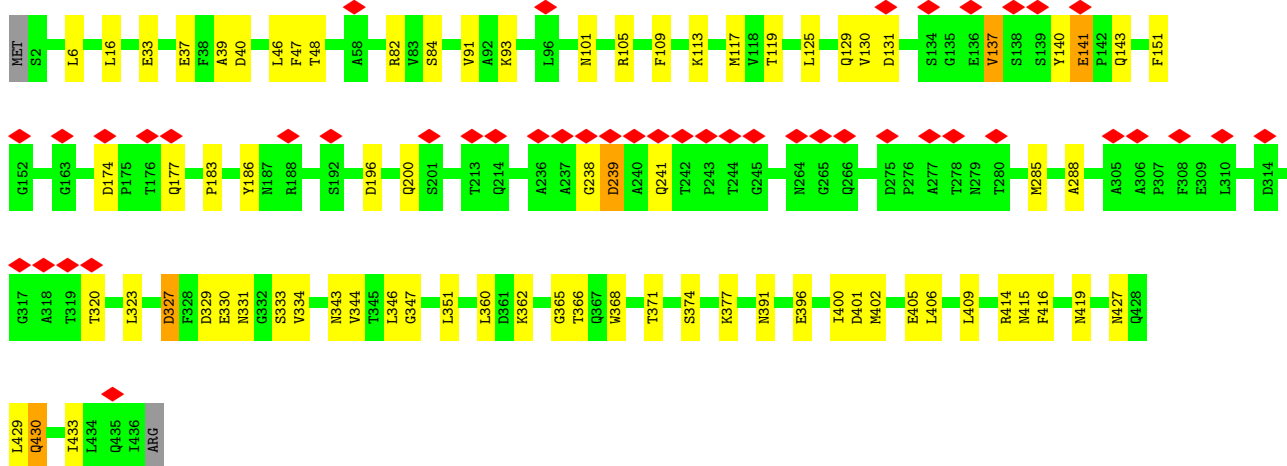
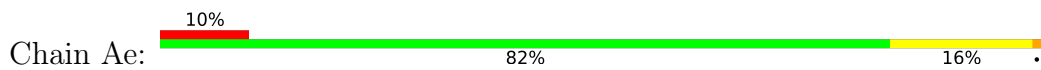

• Molecule 6: Flagellar hook protein FlgE

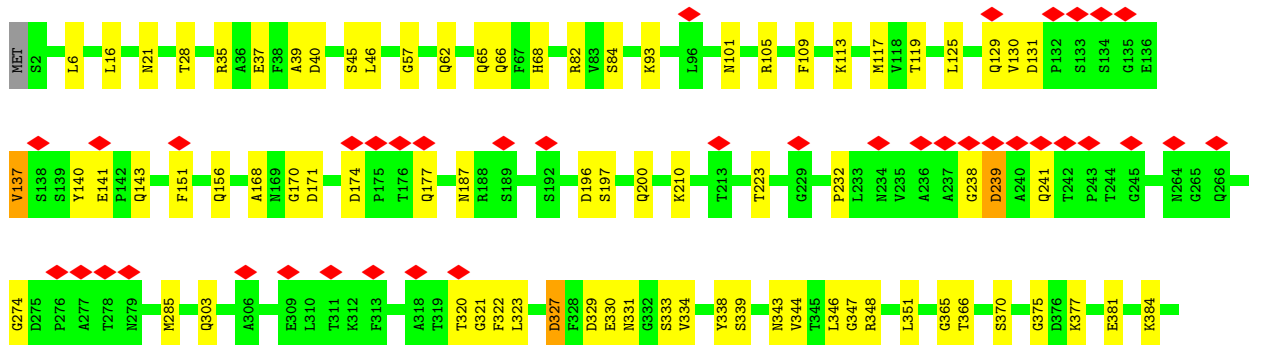
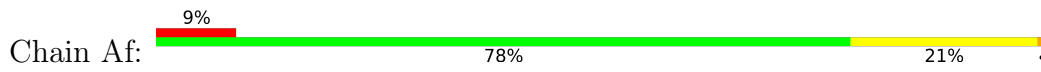

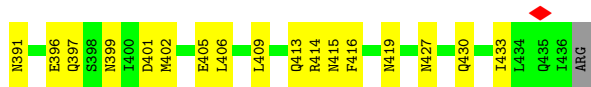

• Molecule 6: Flagellar hook protein FlgE

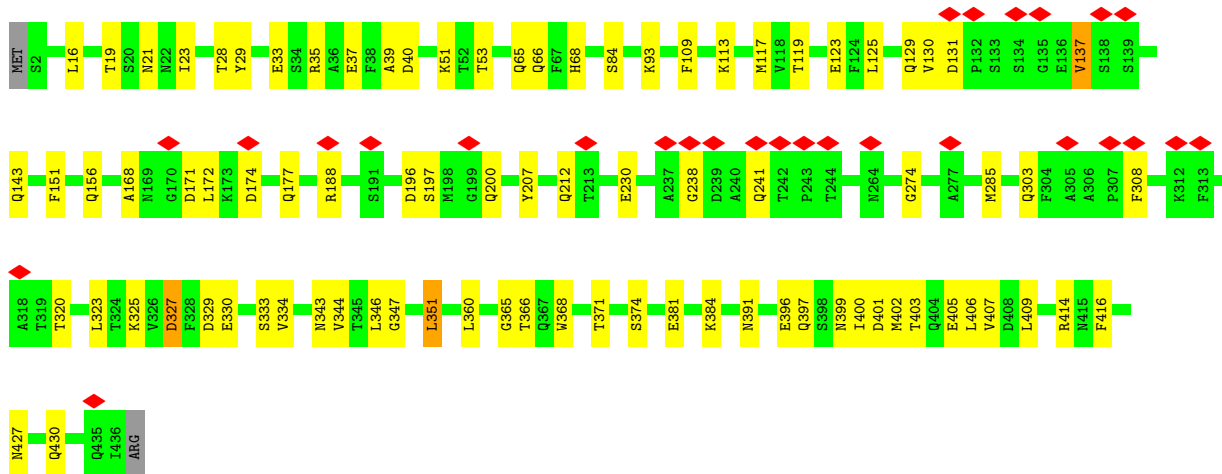
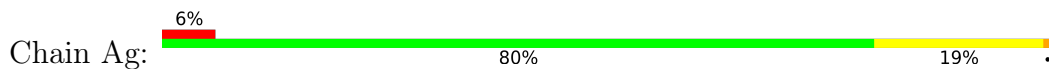

• Molecule 6: Flagellar hook protein FlgE

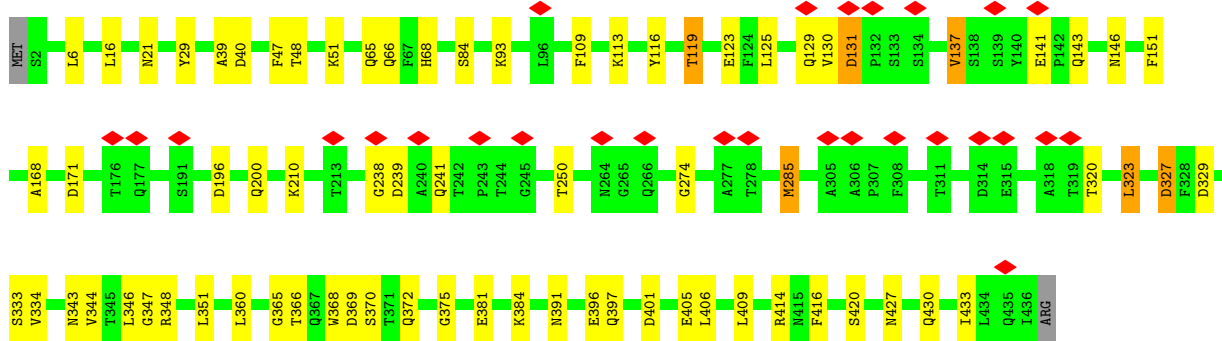
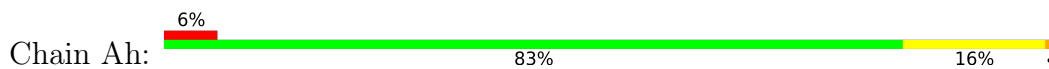

• Molecule 6: Flagellar hook protein FlgE

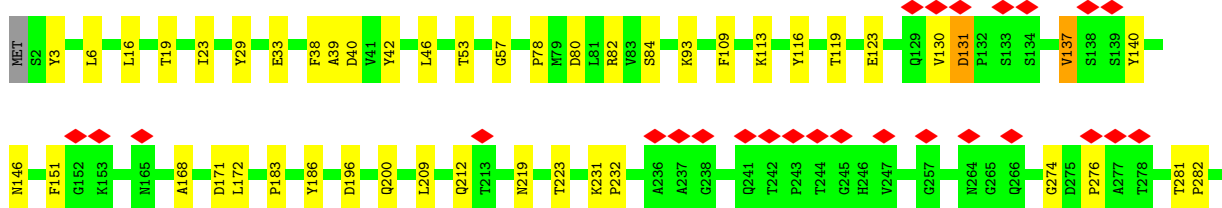
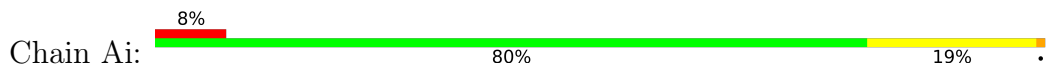

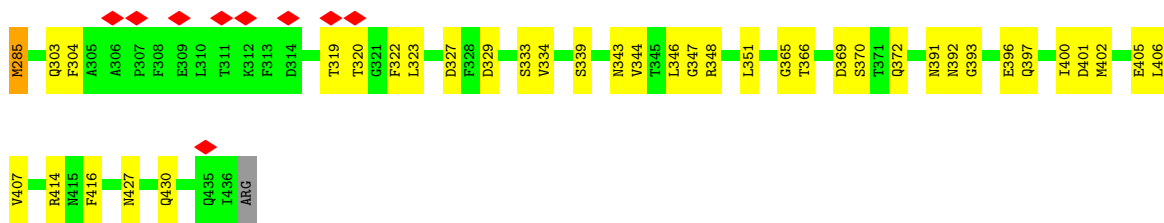

• Molecule 6: Flagellar hook protein FlgE

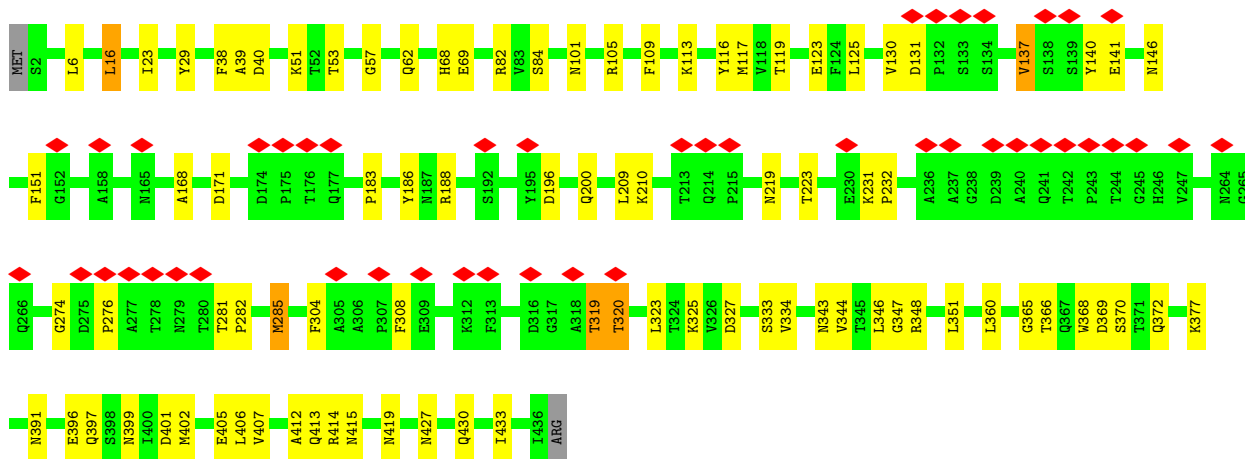
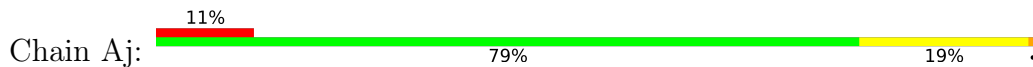

• Molecule 6: Flagellar hook protein FlgE

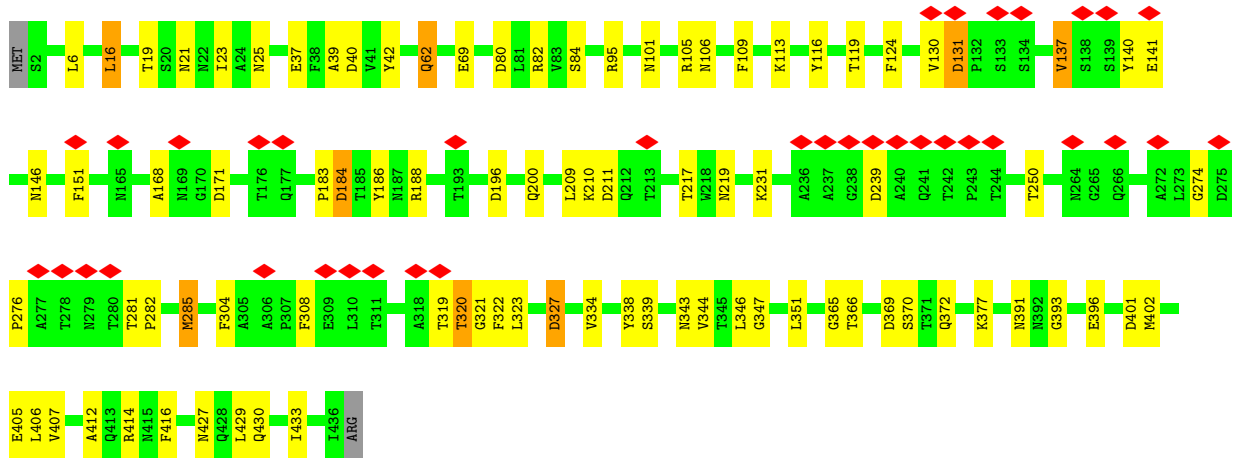
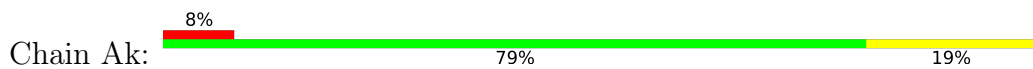

• Molecule 6: Flagellar hook protein FlgE

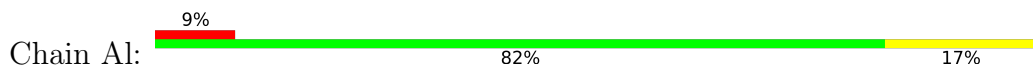

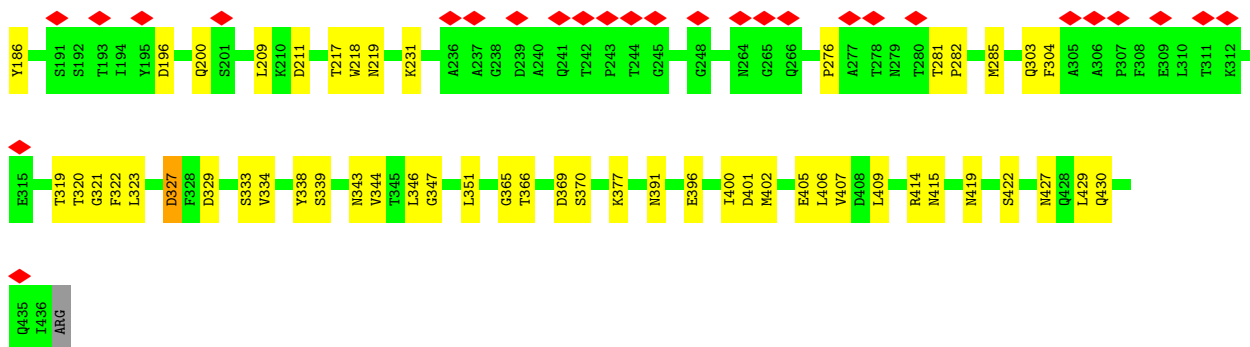

• Molecule 6: Flagellar hook protein FlgE

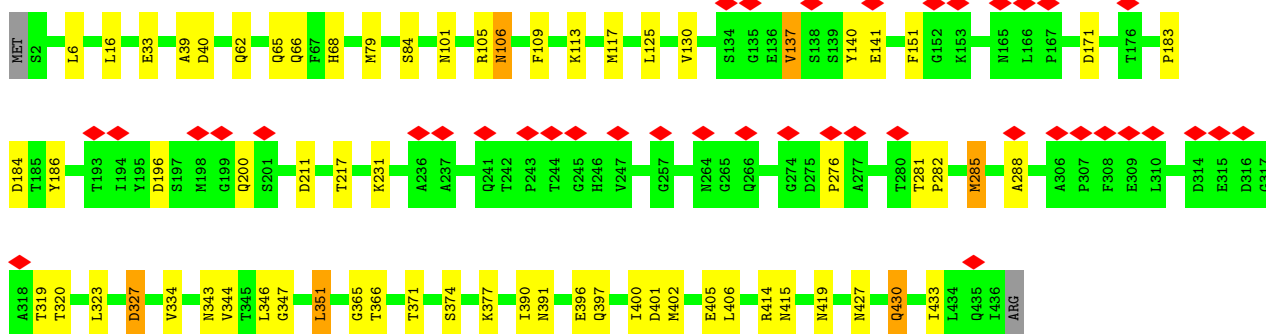
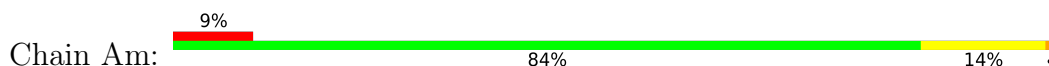

• Molecule 6: Flagellar hook protein FlgE

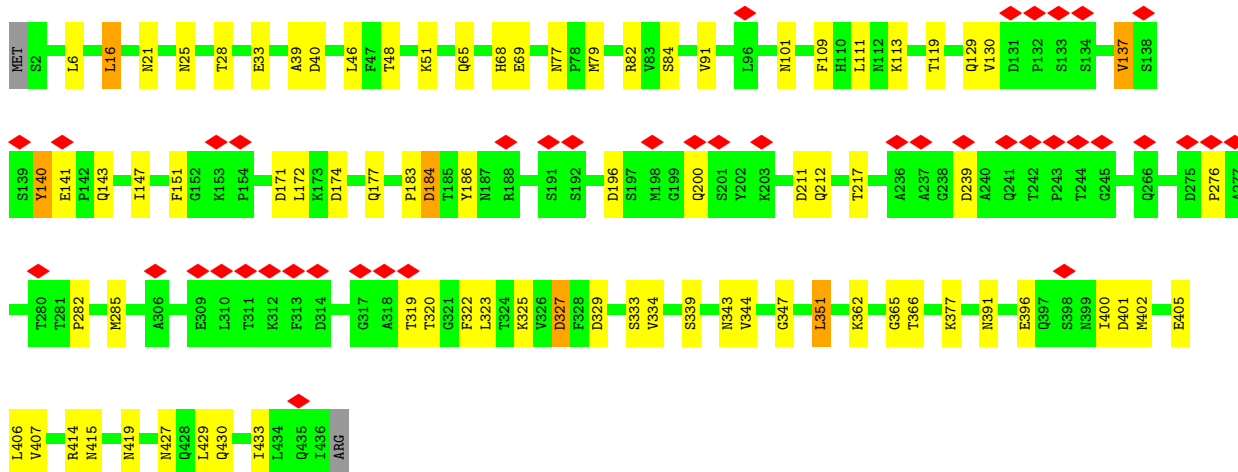
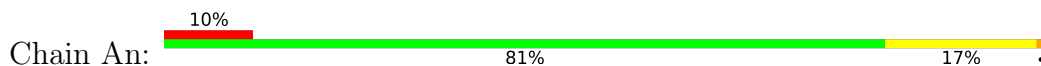

• Molecule 6: Flagellar hook protein FlgE

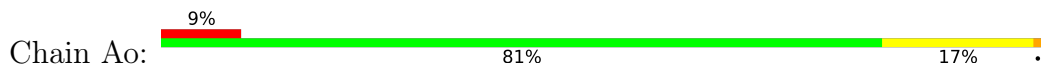

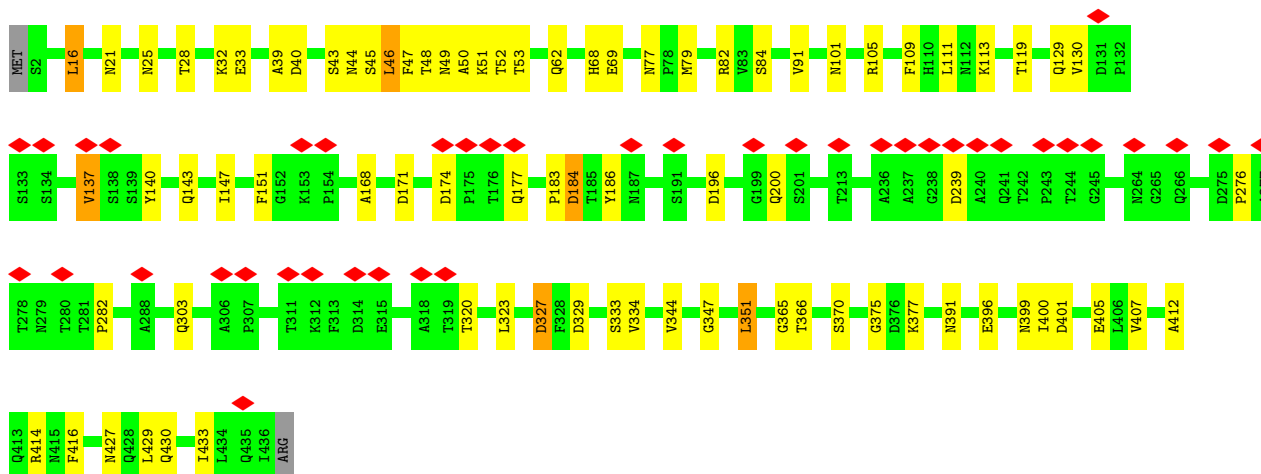

• Molecule 6: Flagellar hook protein FlgE

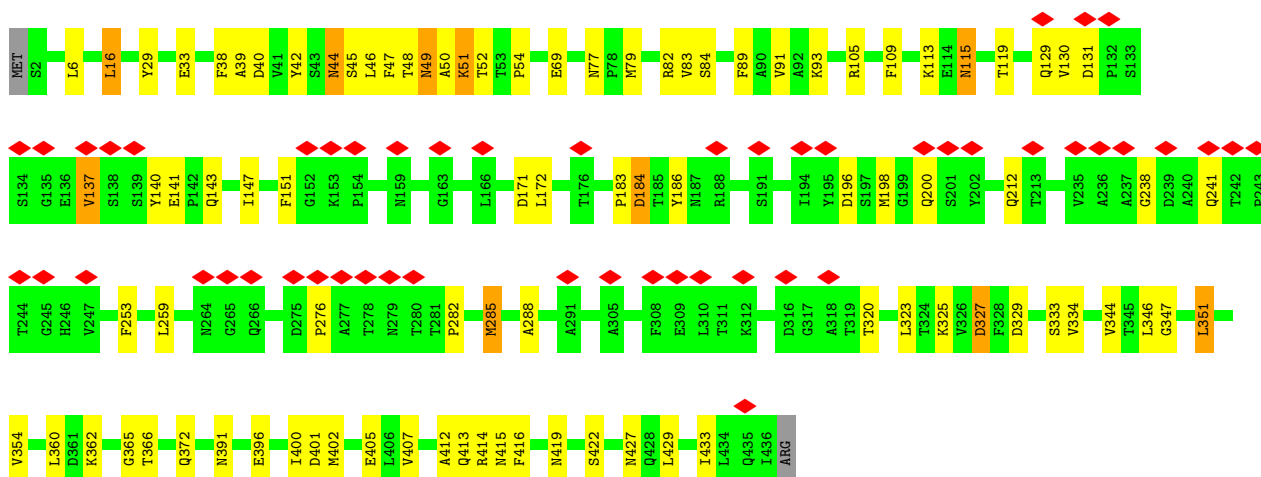
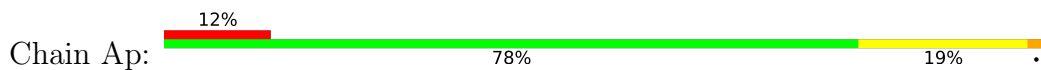

• Molecule 6: Flagellar hook protein FlgE

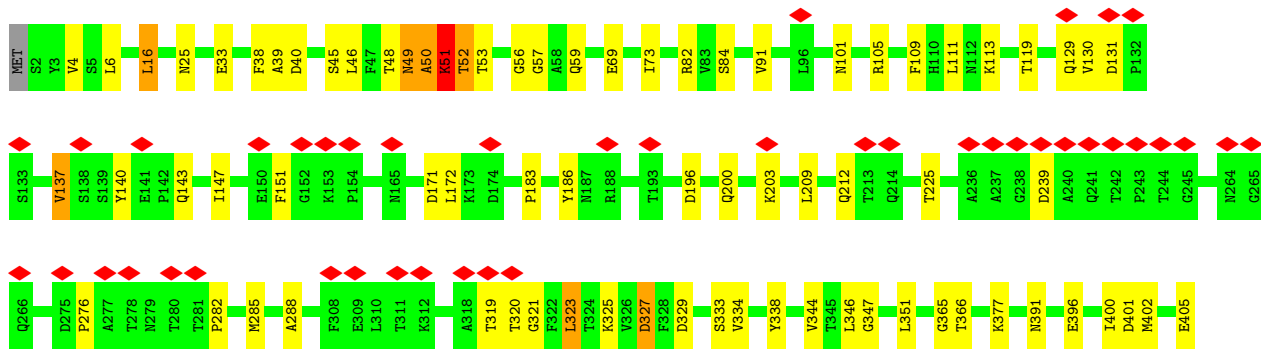
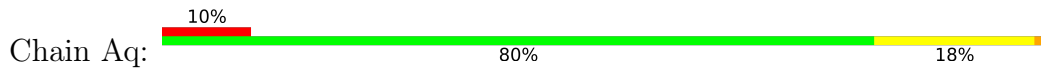

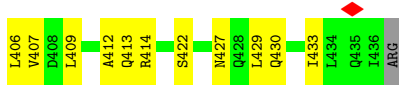

• Molecule 6: Flagellar hook protein FlgE

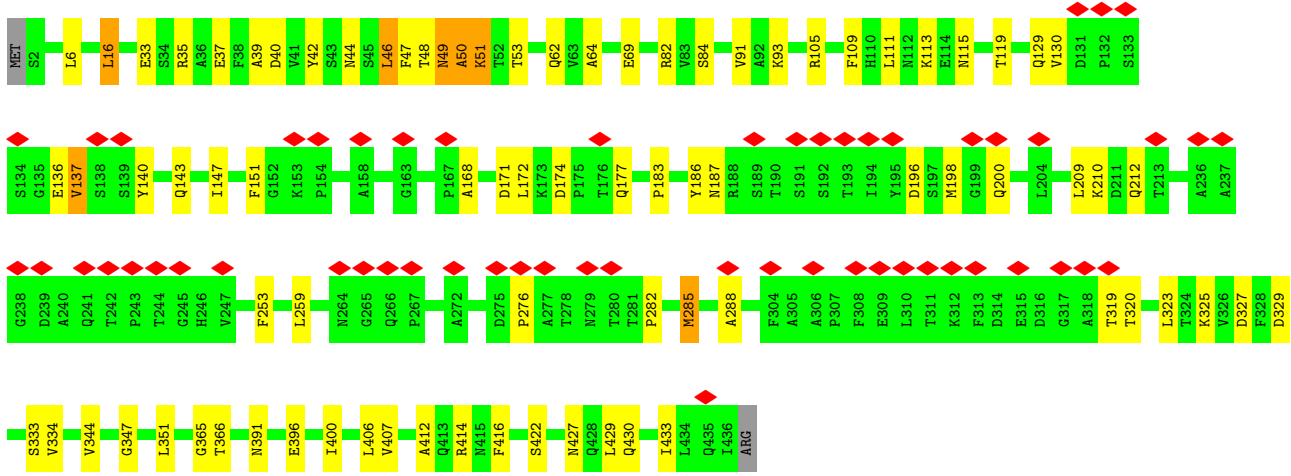
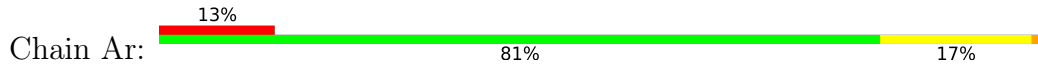

• Molecule 6: Flagellar hook protein FlgE

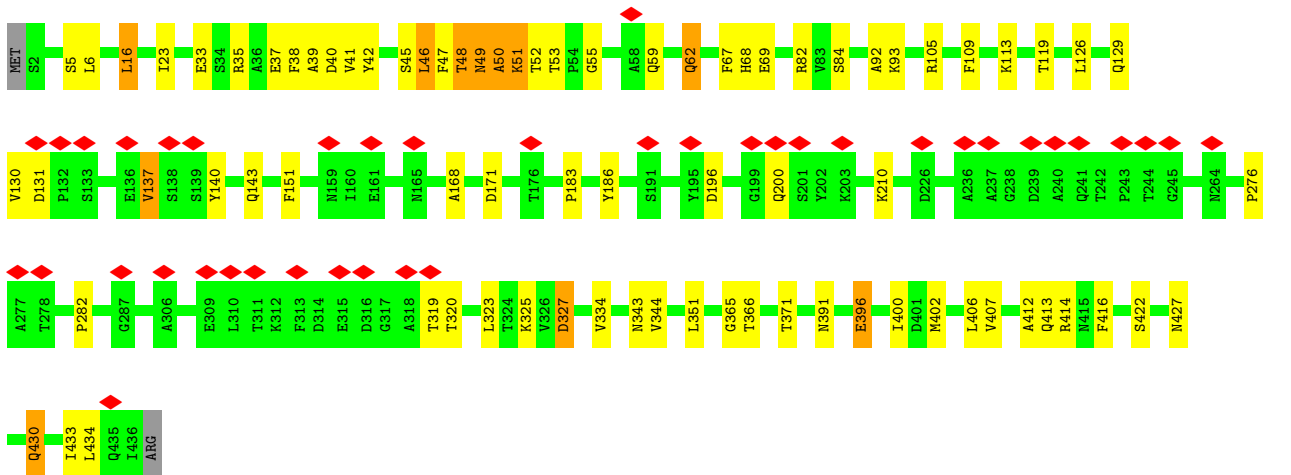
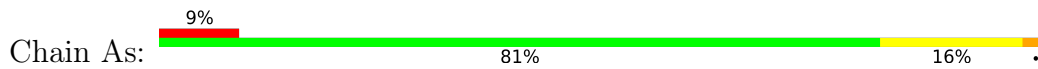

• Molecule 6: Flagellar hook protein FlgE

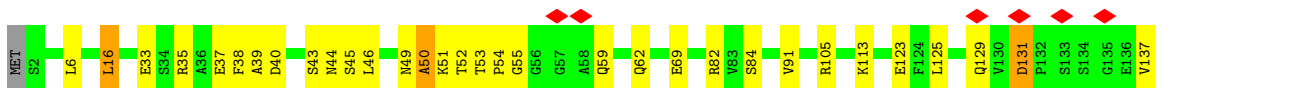
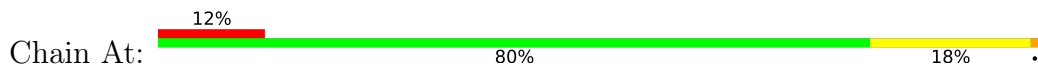

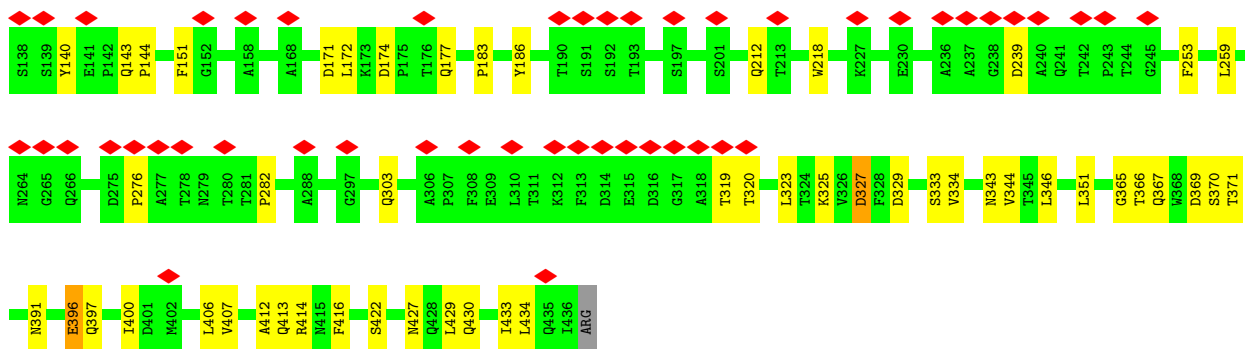

• Molecule 6: Flagellar hook protein FlgE

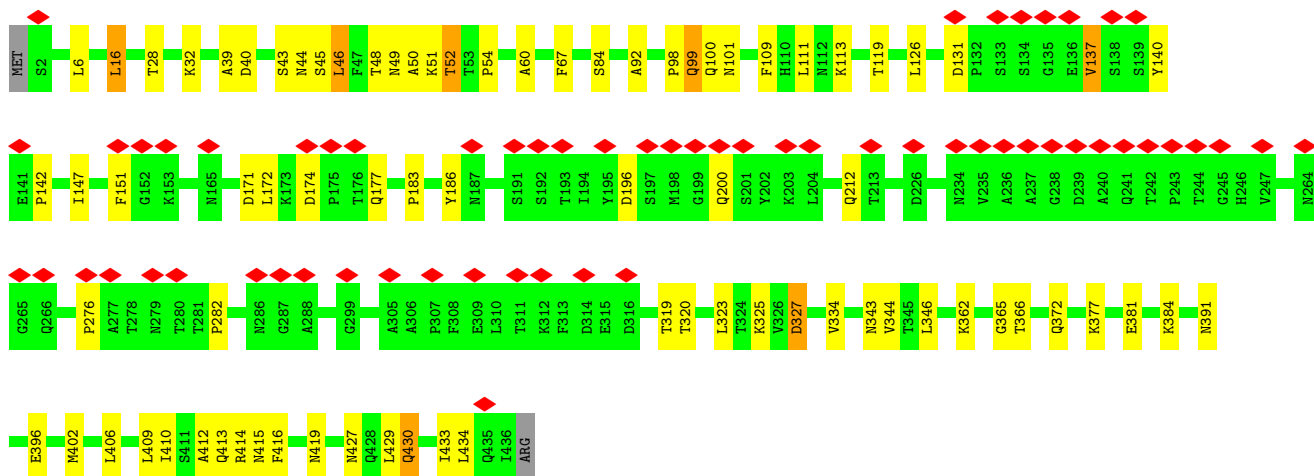
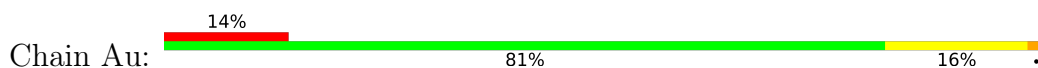

• Molecule 6: Flagellar hook protein FlgE

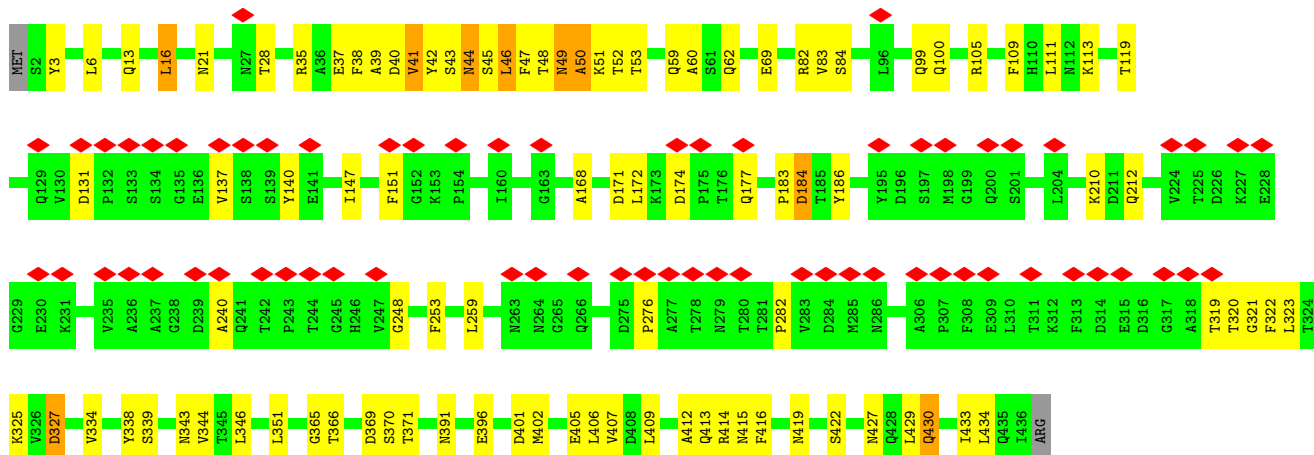
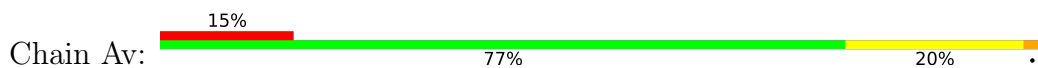

• Molecule 6: Flagellar hook protein FlgE

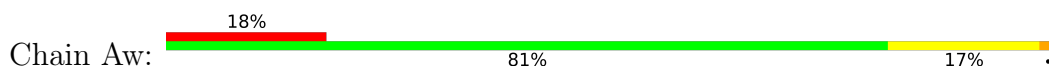

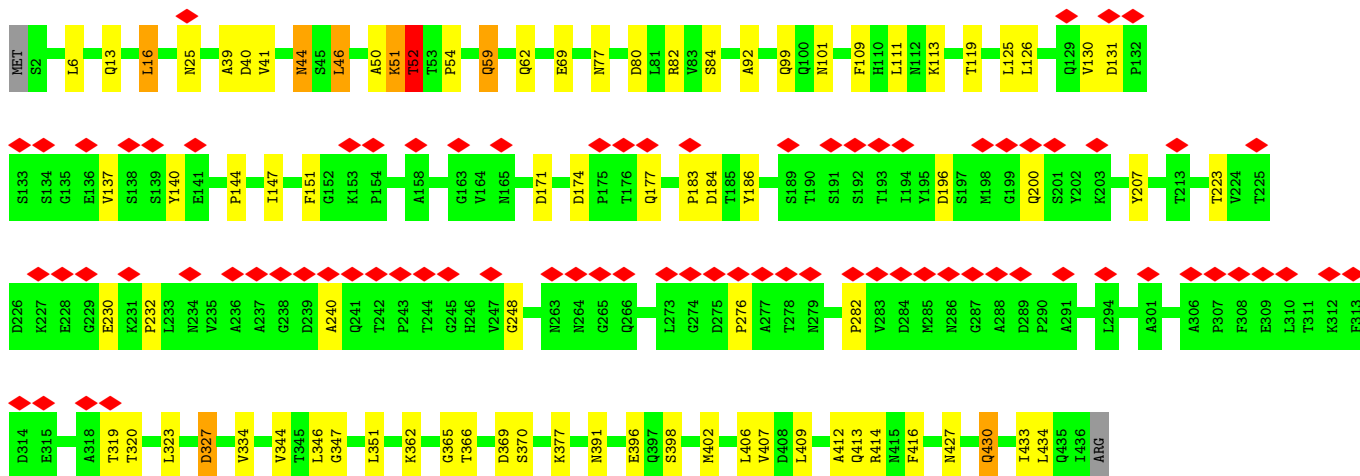

• Molecule 6: Flagellar hook protein FlgE

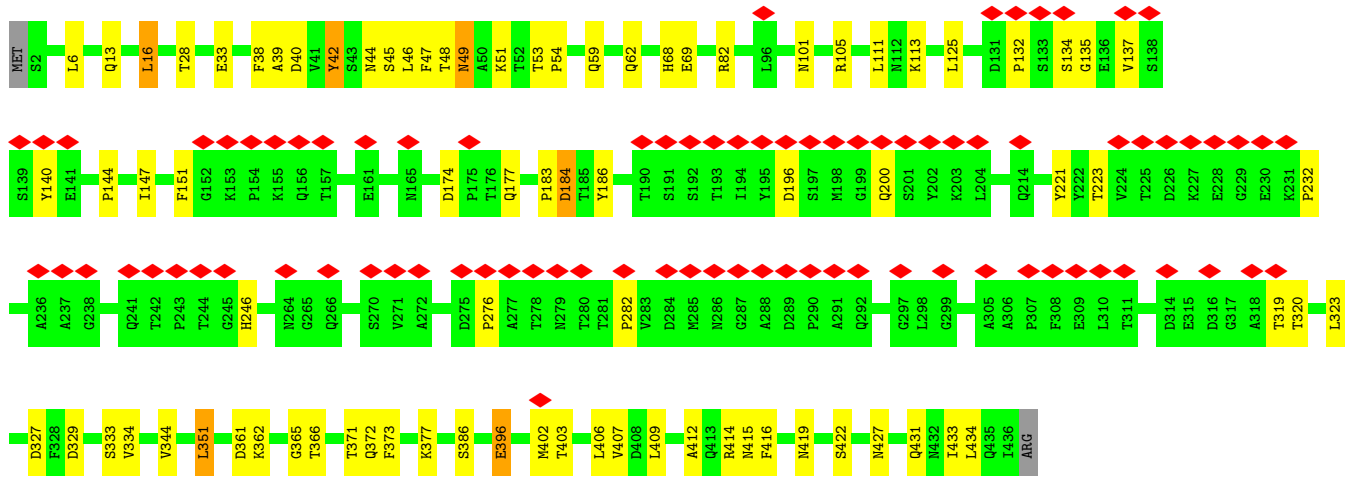
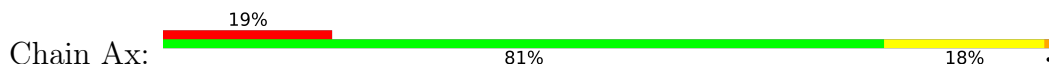

• Molecule 6: Flagellar hook protein FlgE

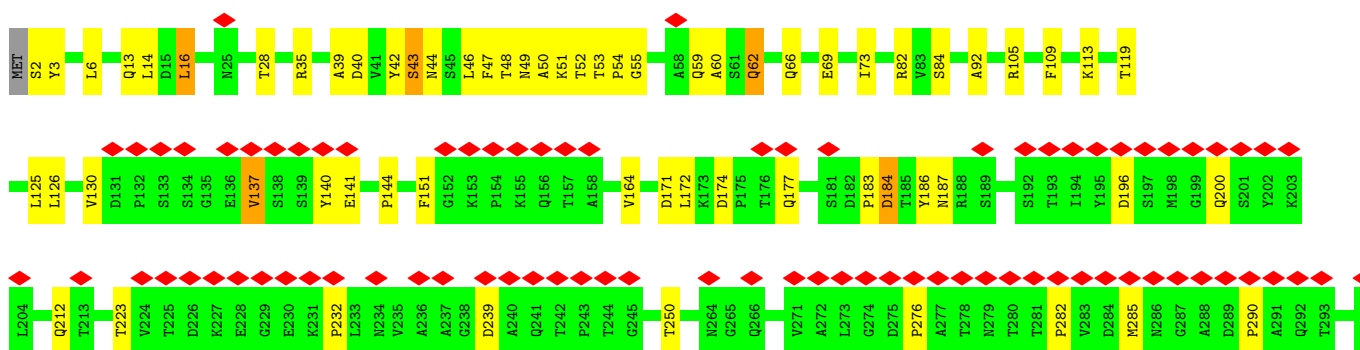
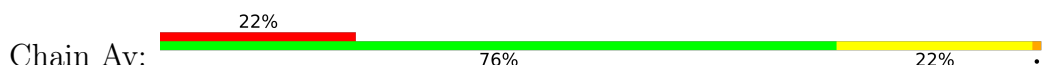

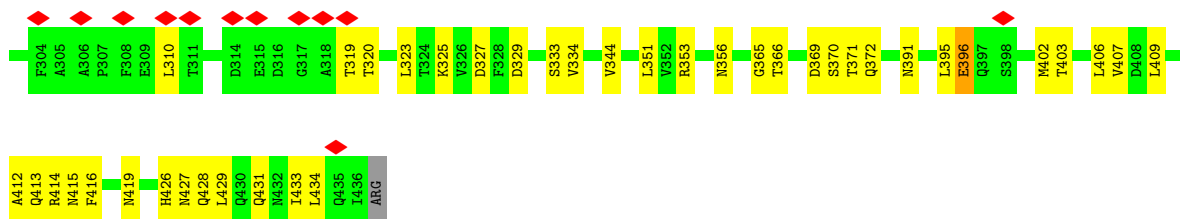

• Molecule 6: Flagellar hook protein FlgE

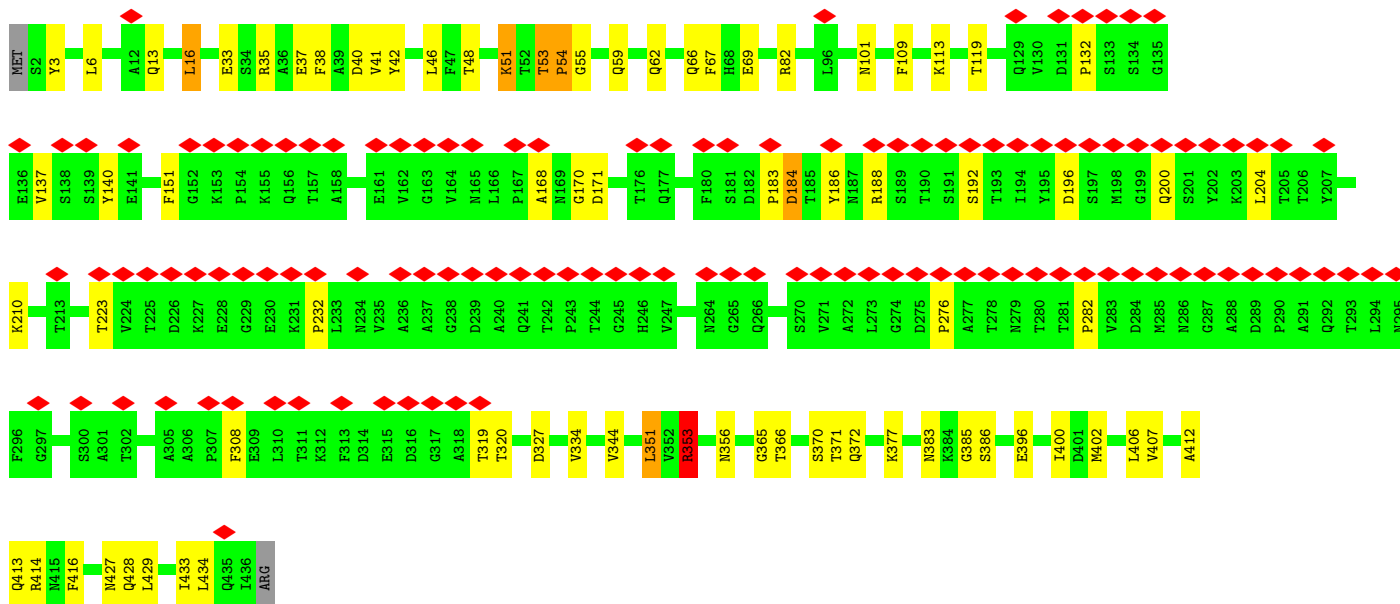
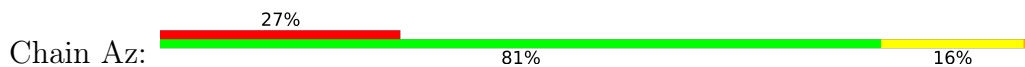

• Molecule 6: Flagellar hook protein FlgE

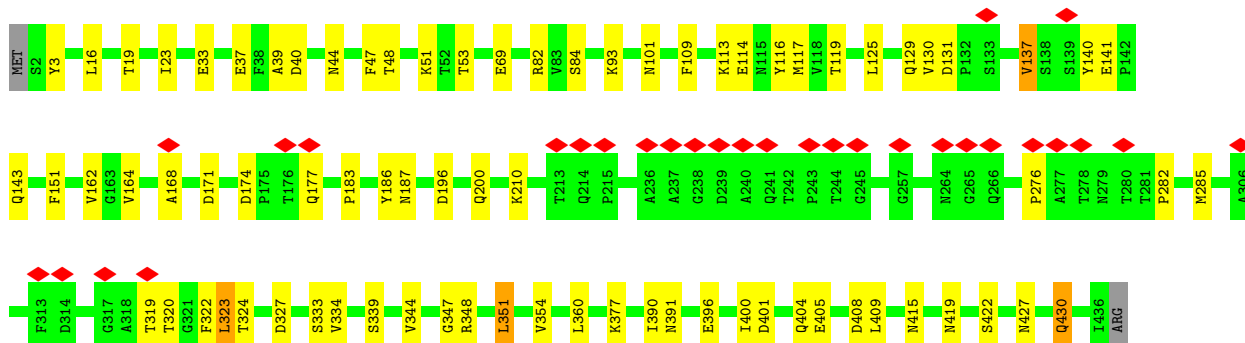
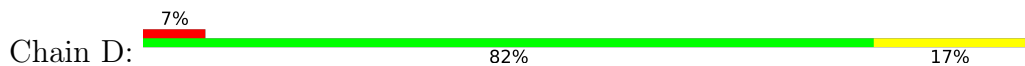

• Molecule 6: Flagellar hook protein FlgE

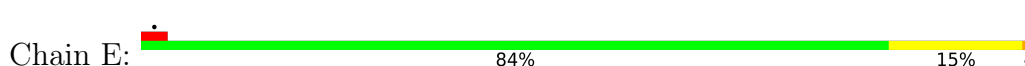

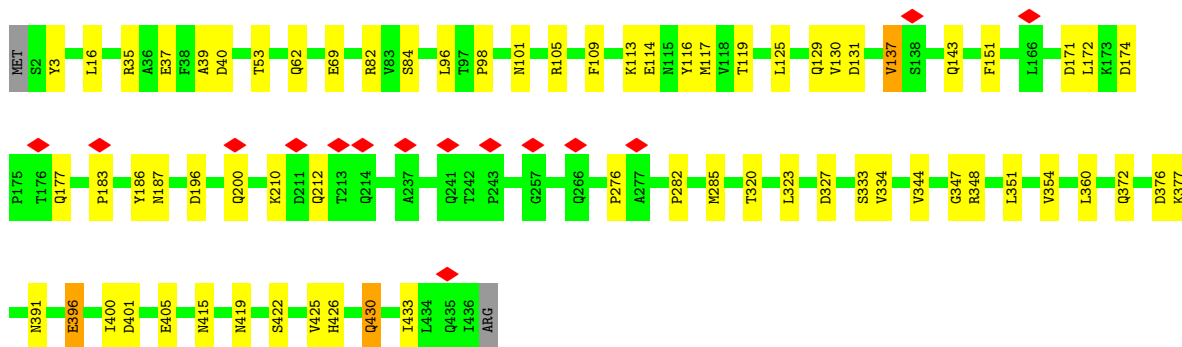

• Molecule 6: Flagellar hook protein FlgE

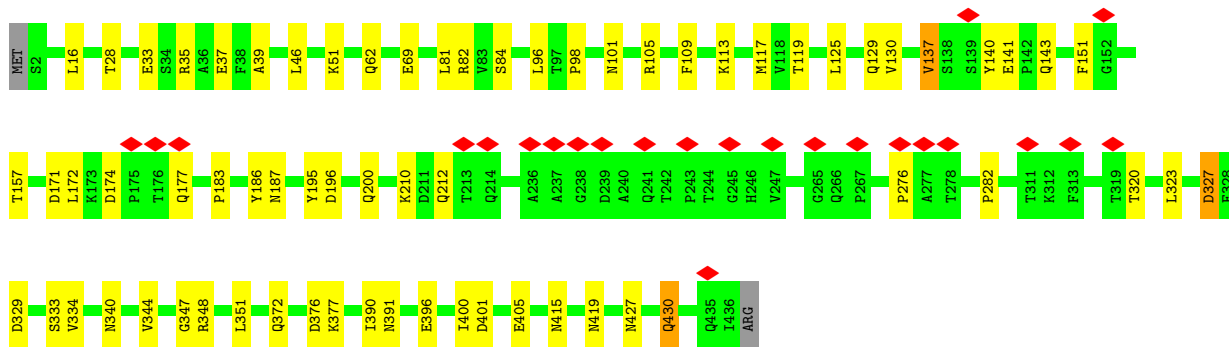
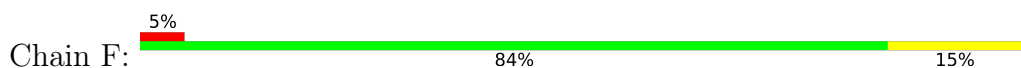

• Molecule 6: Flagellar hook protein FlgE

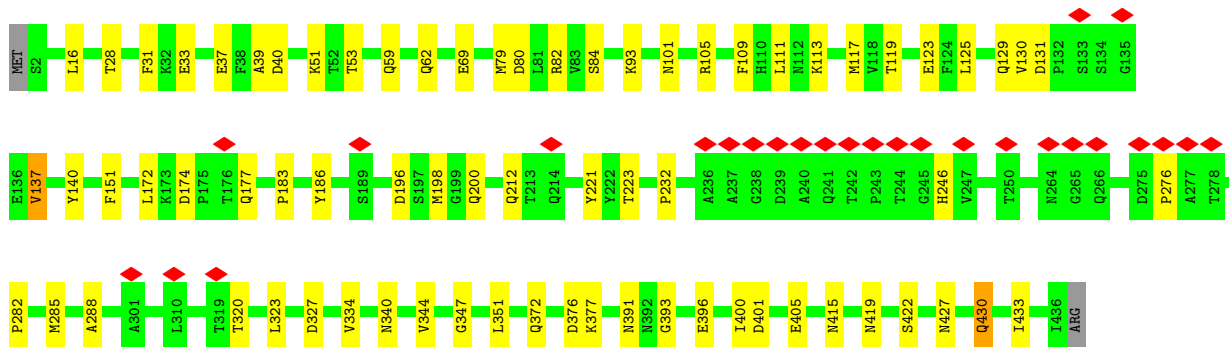
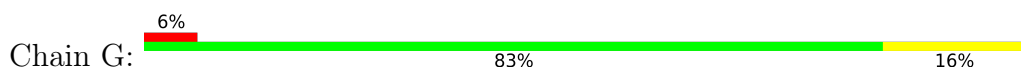

• Molecule 6: Flagellar hook protein FlgE

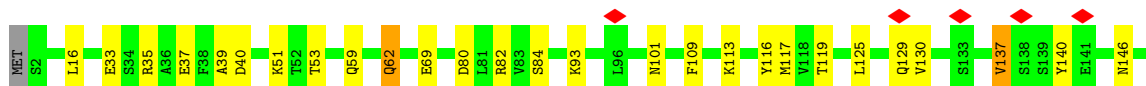
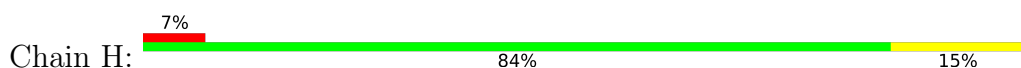

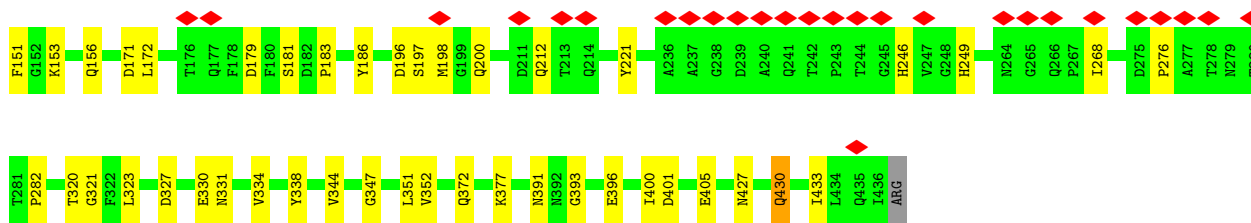

• Molecule 6: Flagellar hook protein FlgE

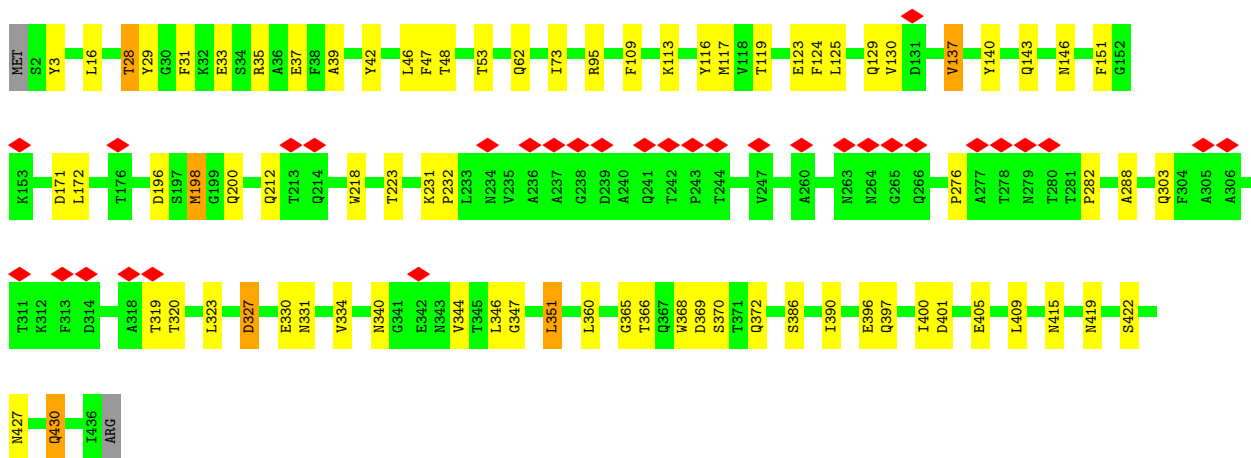
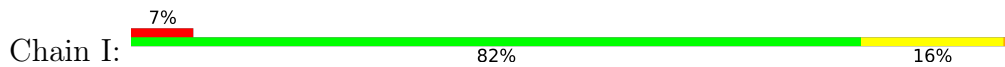

• Molecule 6: Flagellar hook protein FlgE

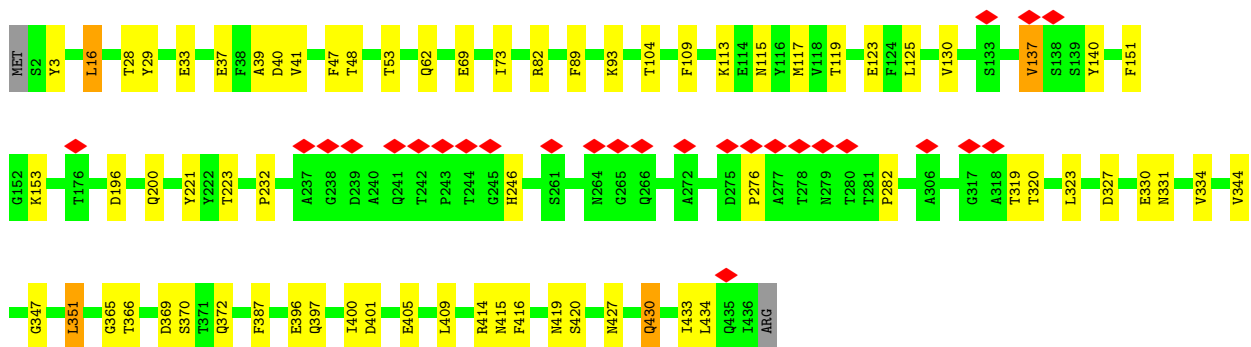
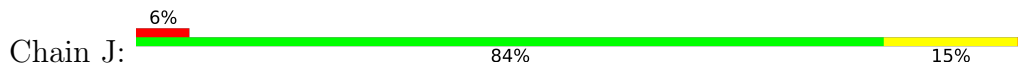

• Molecule 6: Flagellar hook protein FlgE

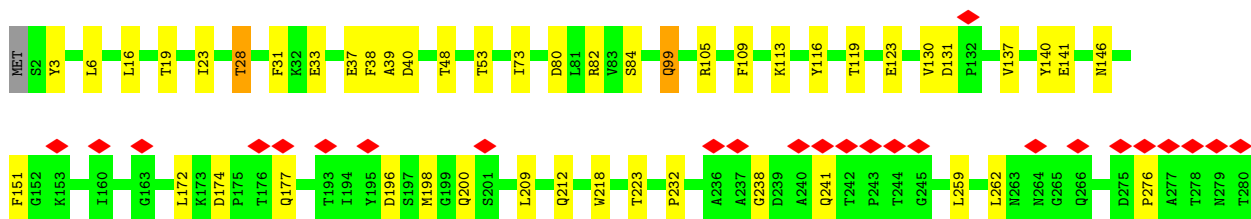
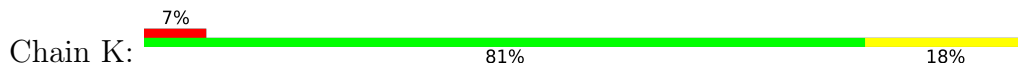

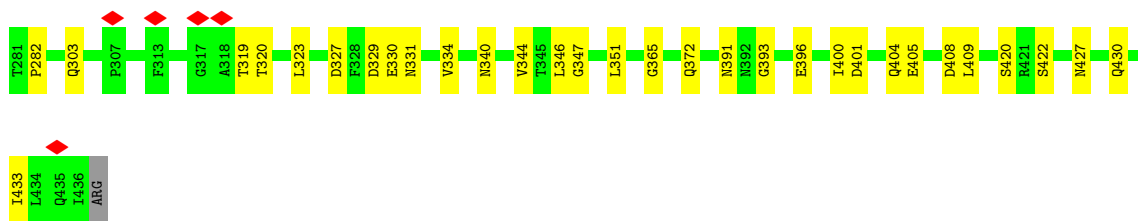

• Molecule 6: Flagellar hook protein FlgE

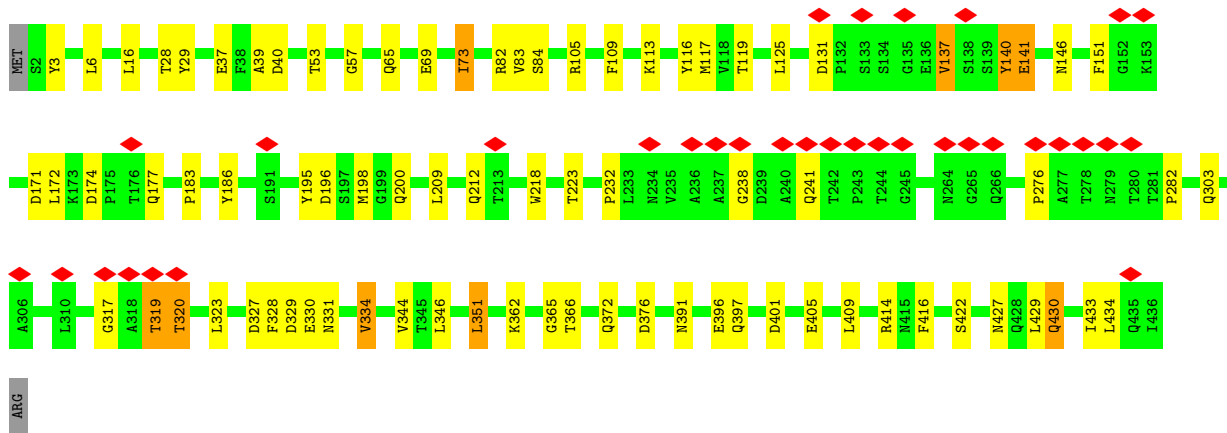
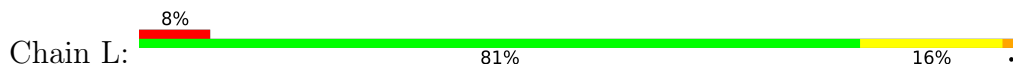

• Molecule 6: Flagellar hook protein FlgE

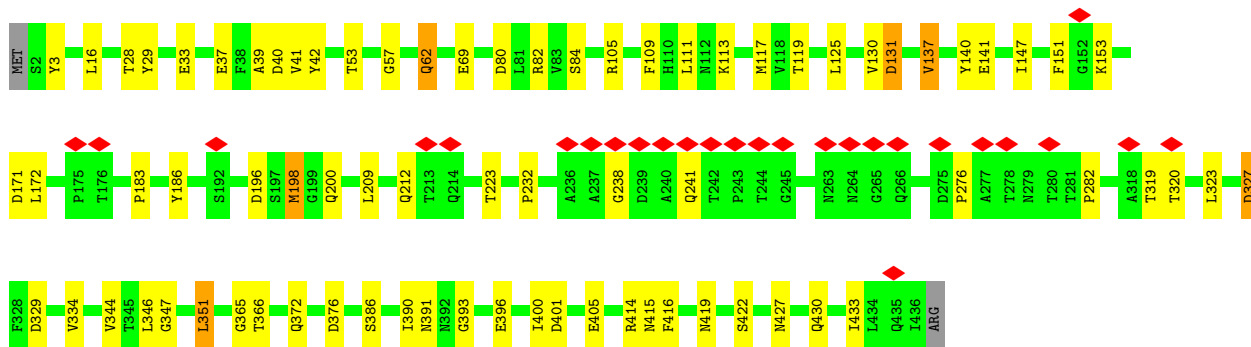
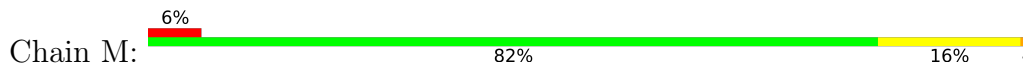

• Molecule 6: Flagellar hook protein FlgE

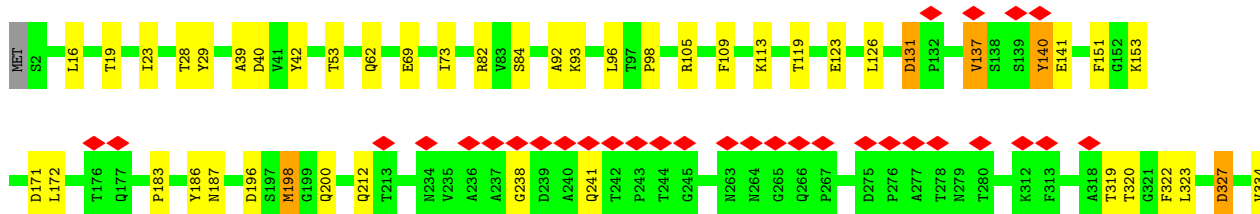
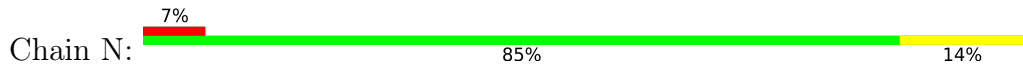

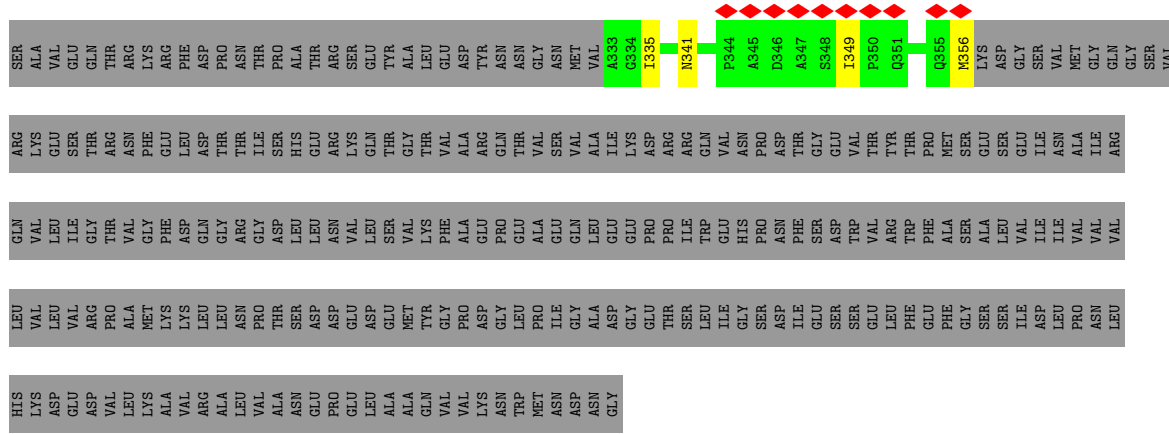

● Molecule 7: Flagellar M-ring protein

Chain AK: .. 96%

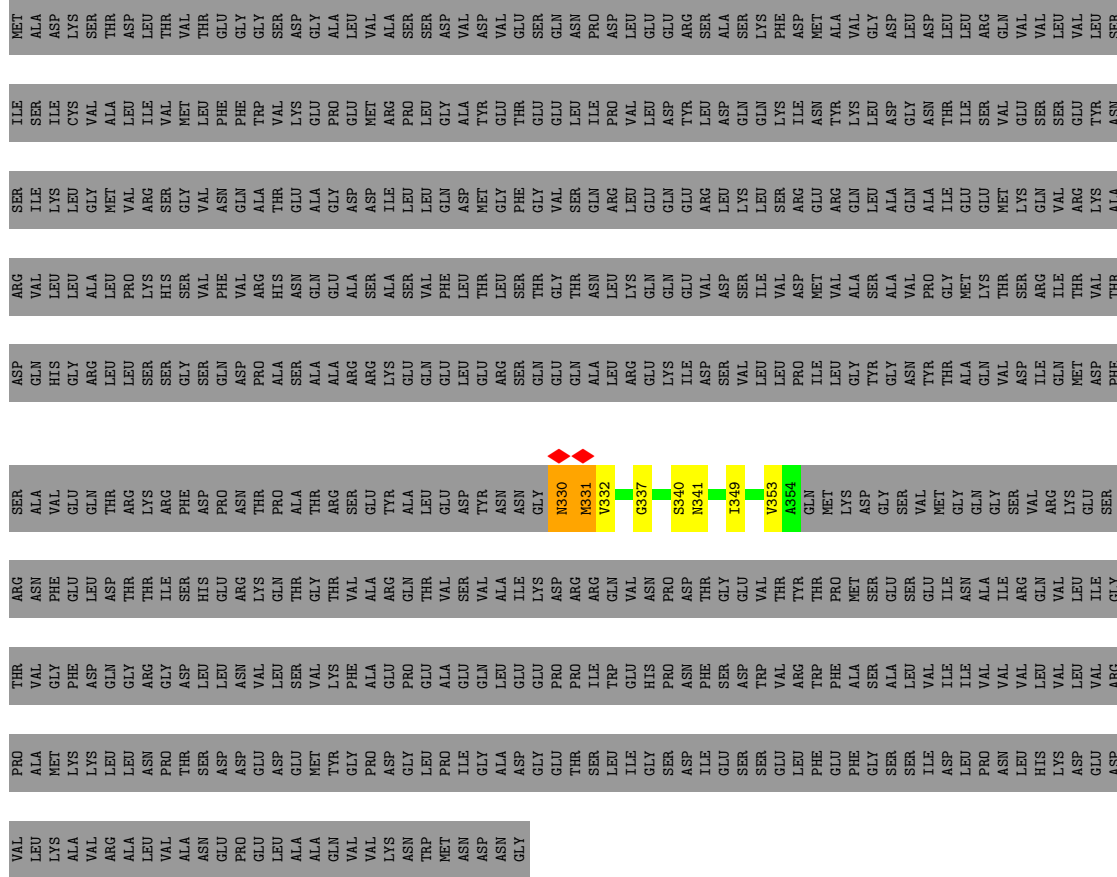

● Molecule 7: Flagellar M-ring protein

Chain AL: 5% 94%



ALA ASN
GLU PRO
PHO GLU
LEU LEU
ALA ALA
GLN
GLN VAL
VAL VAL
VAL LYS
ASN LYS
TRP MET
ASN ASN
ASN GLY

• Molecule 7: Flagellar M-ring protein

Chain AN: 5% 94%

MET ALA ASP LYS VAL THR ASP LEU THR THR VAL VAL MET LEU THR VAL PHE GLU GLY GLY SER ASP GLY ALA ALA VAL VAL VAL

ILE SER ILE ILE CYS VAL VAL ALA LEU ILE ILE SER VAL MET MET PHE VAL VAL VAL VAL VAL VAL VAL VAL VAL VAL VAL VAL VAL VAL

SER ILE LYS LEU CYS MET GLY VAL

ARG VAL LEU

ASP GLN HIS GLY THR

SER ALA VAL GLU GLN THR

ARG LYS GLN THR

ASN VAL LEU LEU VAL PHE VAL

ASP GLU ASP GLU MET THR TYR GLY ASP

PRO
GLU
ALA
LEU
GLN
VAL
VAL
LYS
ASP
ASN
ASP
ASN
ASN
GLY

• Molecule 7: Flagellar M-ring protein

Chain AO: . . . 94%

MET ALA ASP LYS VAL THR ASP LEU THR THR VAL VAL MET LEU THR VAL PHE GLU GLY GLY SER ASP GLY ALA ALA VAL VAL VAL

ILE SER ILE ILE CYS VAL VAL ALA LEU ILE ILE SER VAL MET MET PHE VAL VAL VAL VAL VAL VAL VAL VAL VAL VAL VAL VAL VAL VAL

SER ILE LYS LEU CYS MET GLY VAL

ARG VAL LEU

ASP GLN HIS GLY THR

SER ALA VAL GLU GLN THR



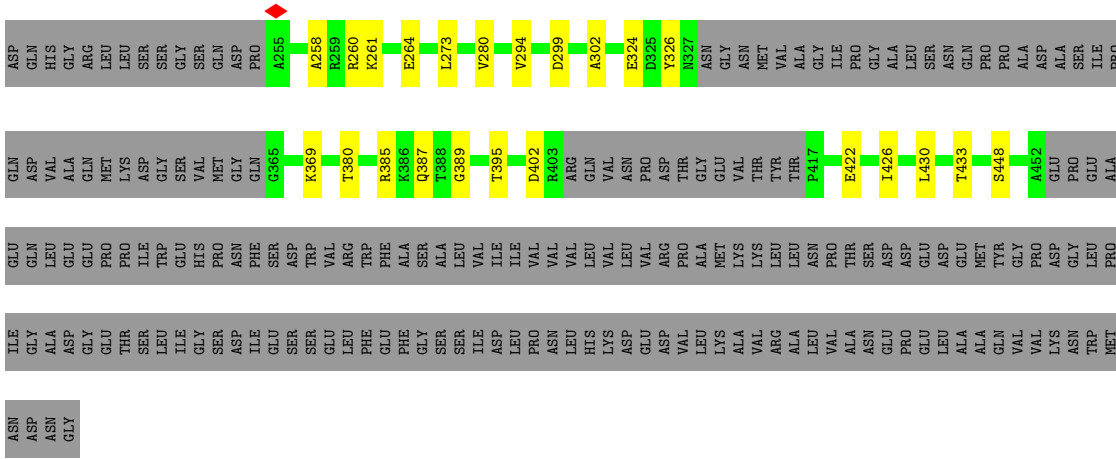

• Molecule 7: Flagellar M-ring protein

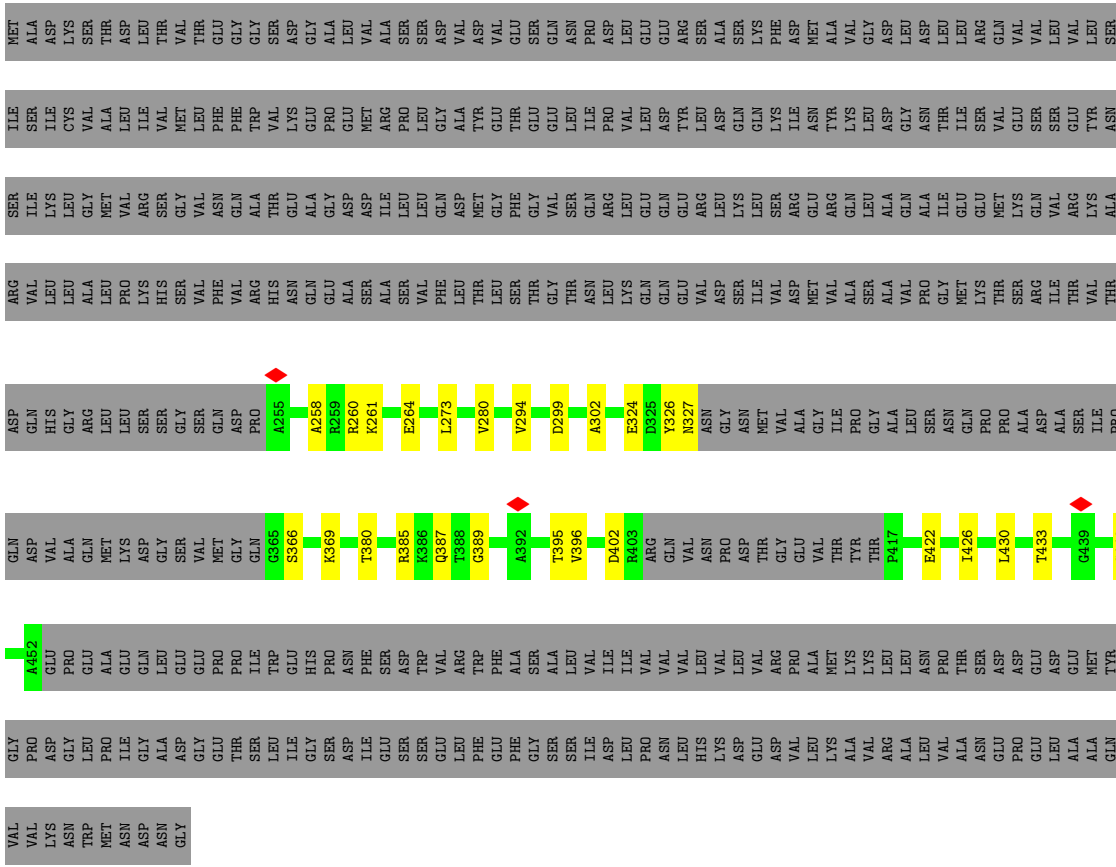

• Molecule 7: Flagellar M-ring protein

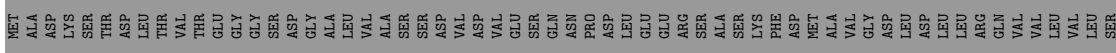

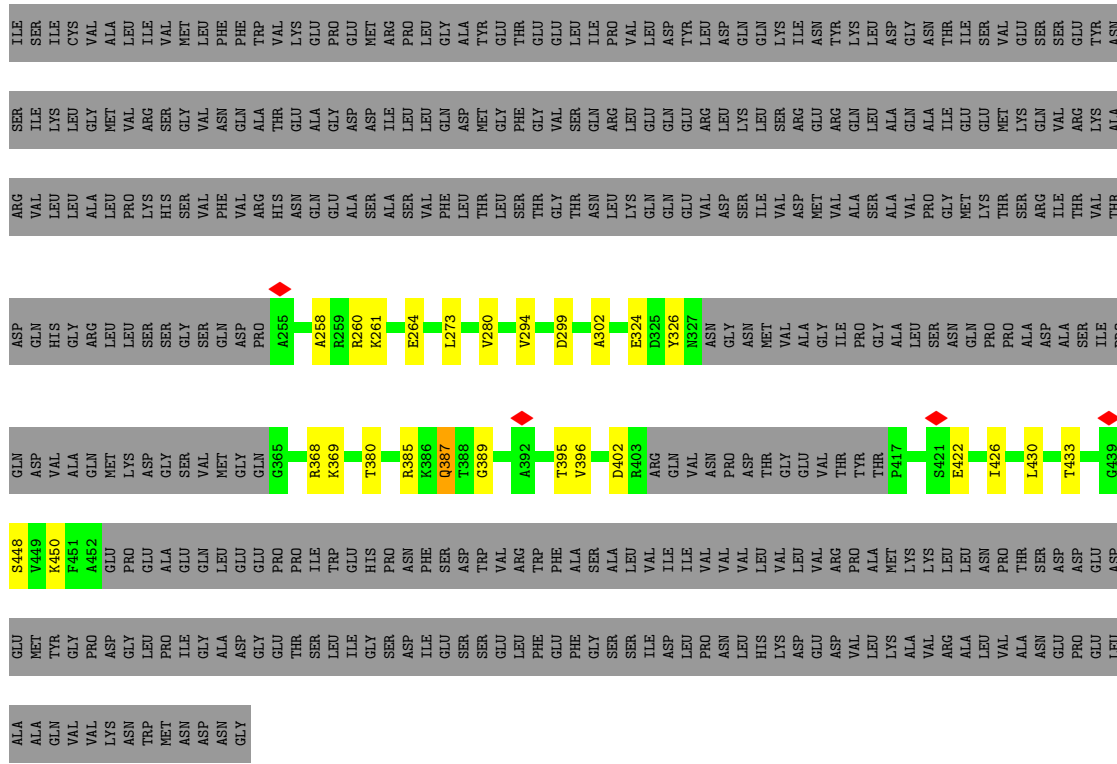

• Molecule 7: Flagellar M-ring protein

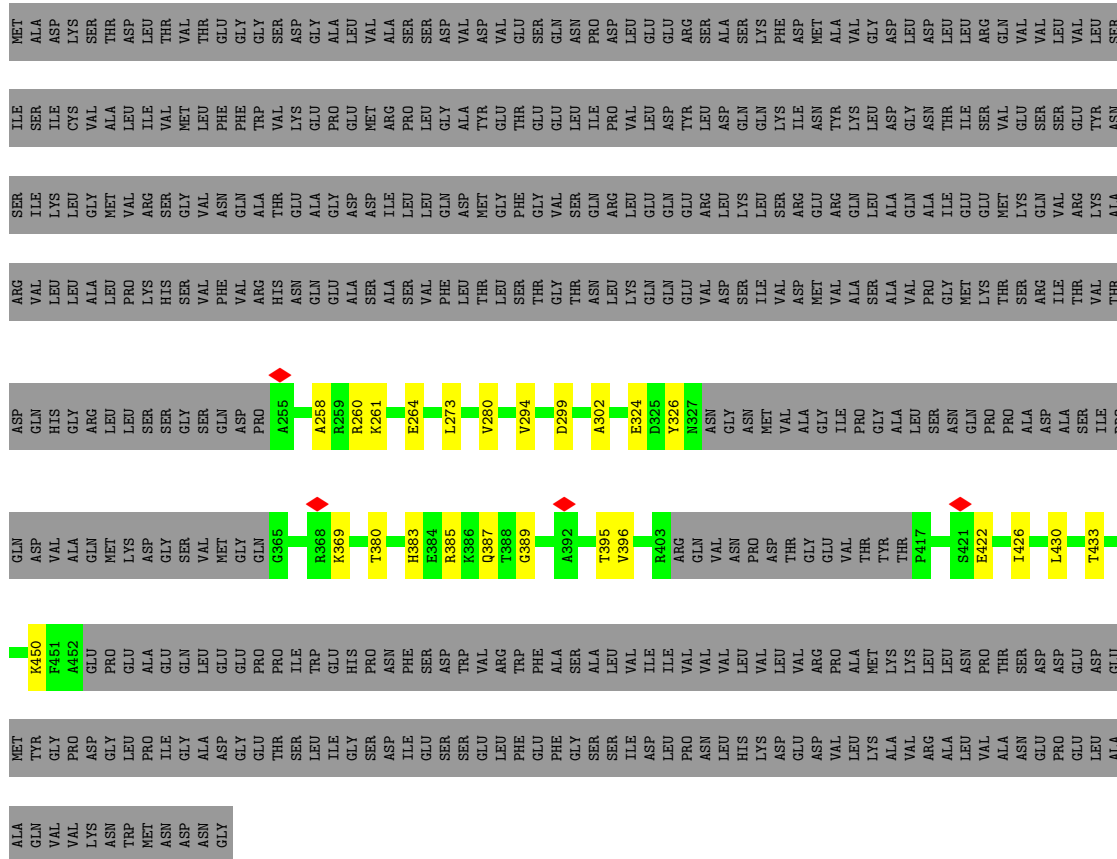

• Molecule 7: Flagellar M-ring protein

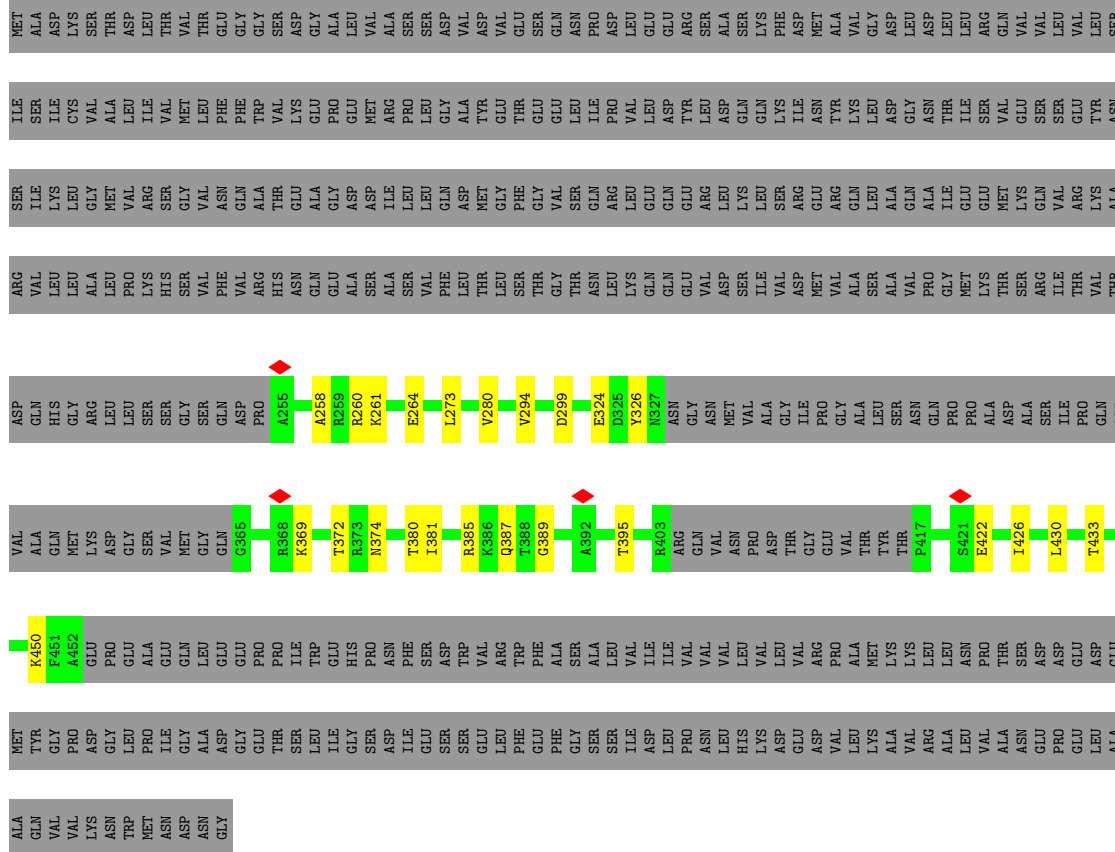

• Molecule 7: Flagellar M-ring protein

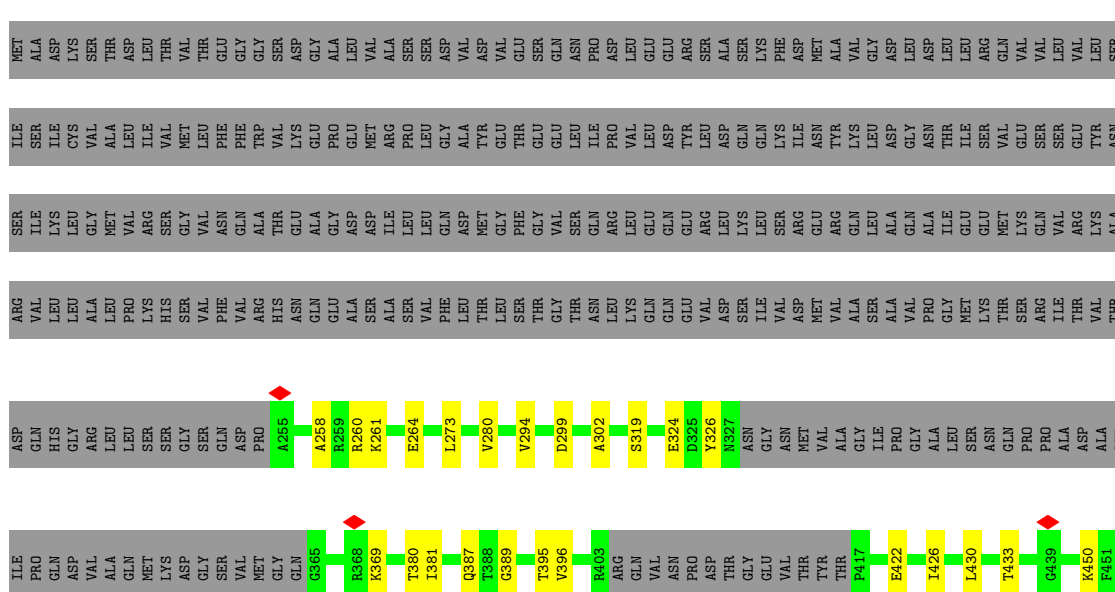

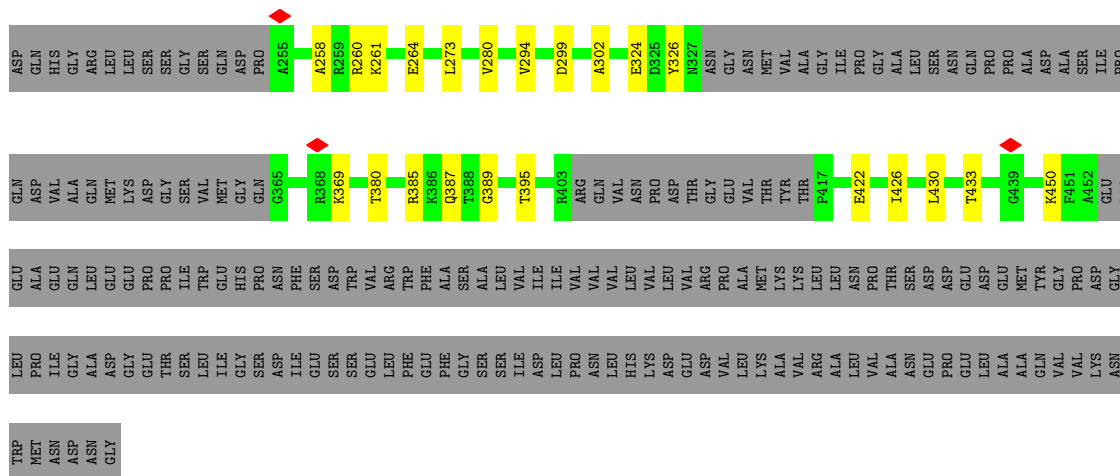

• Molecule 7: Flagellar M-ring protein

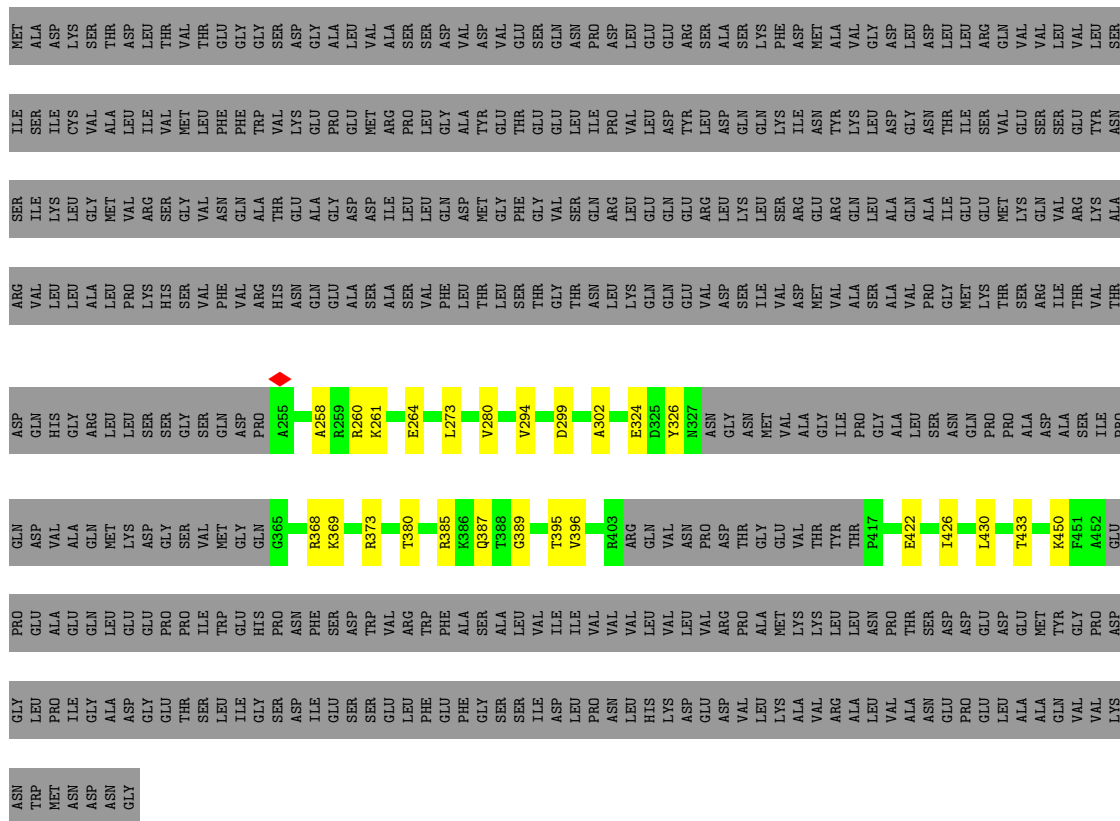

• Molecule 7: Flagellar M-ring protein

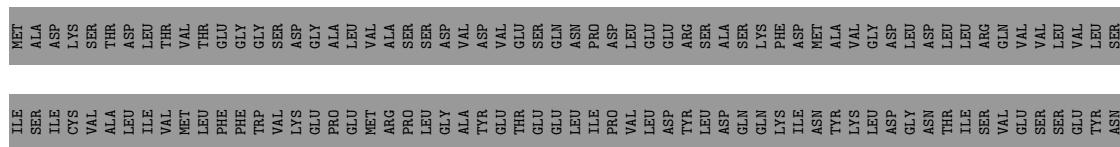

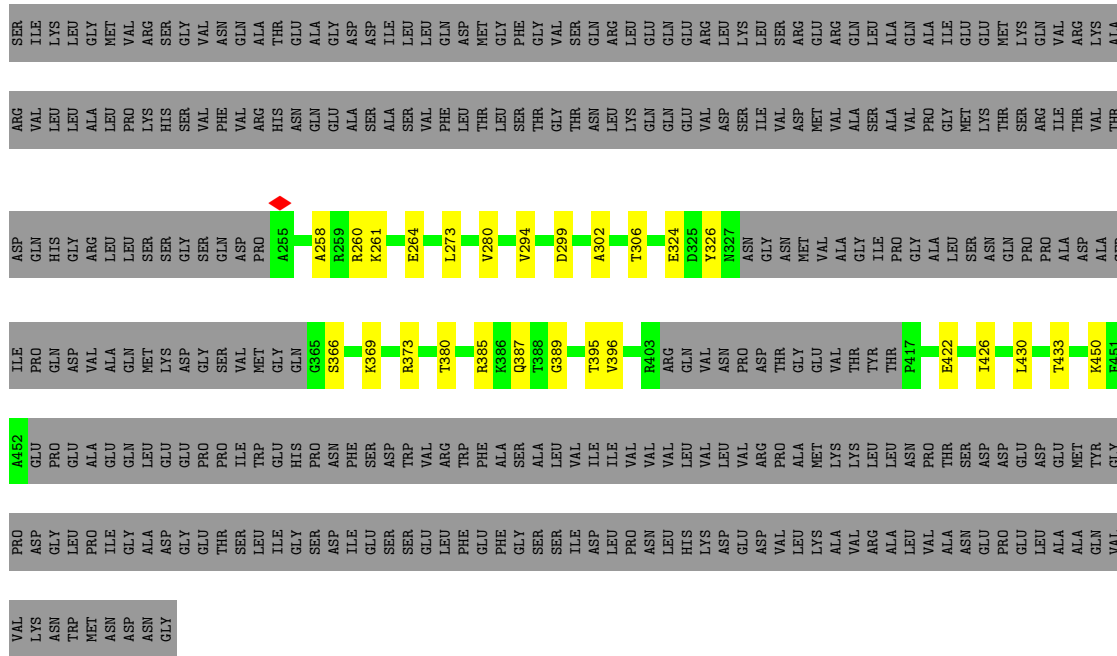

• Molecule 7: Flagellar M-ring protein

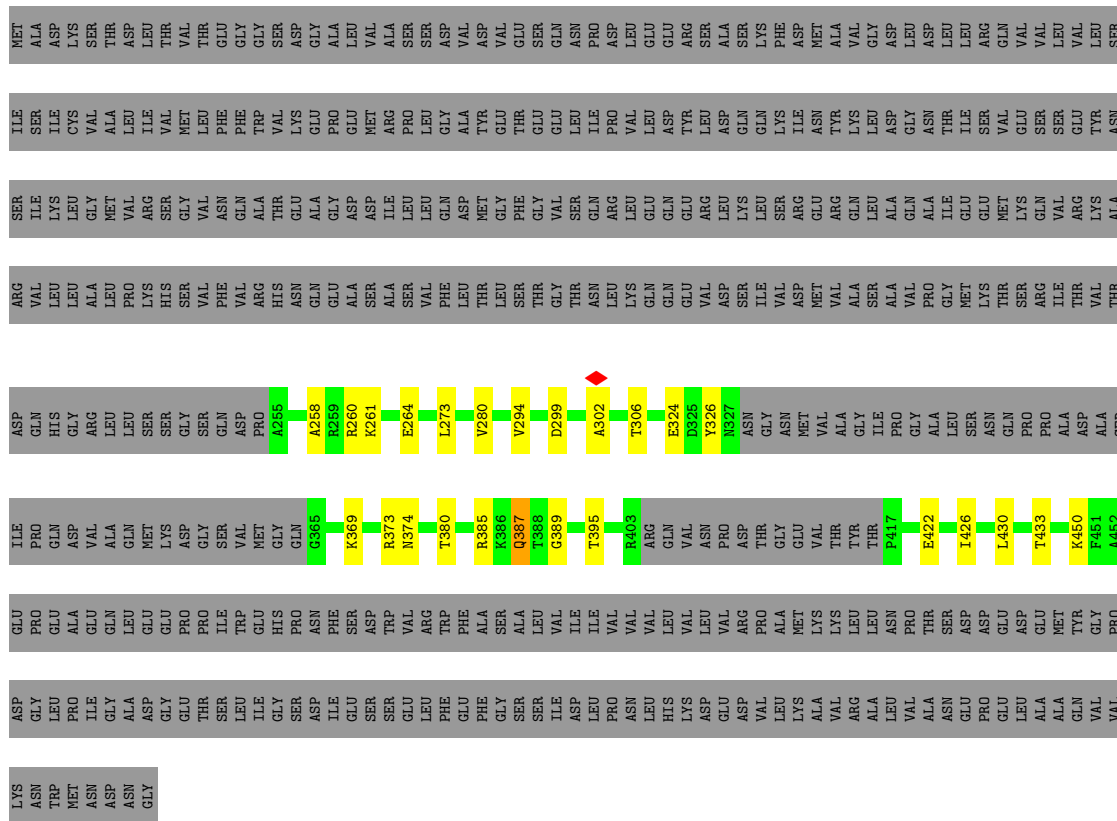

• Molecule 7: Flagellar M-ring protein



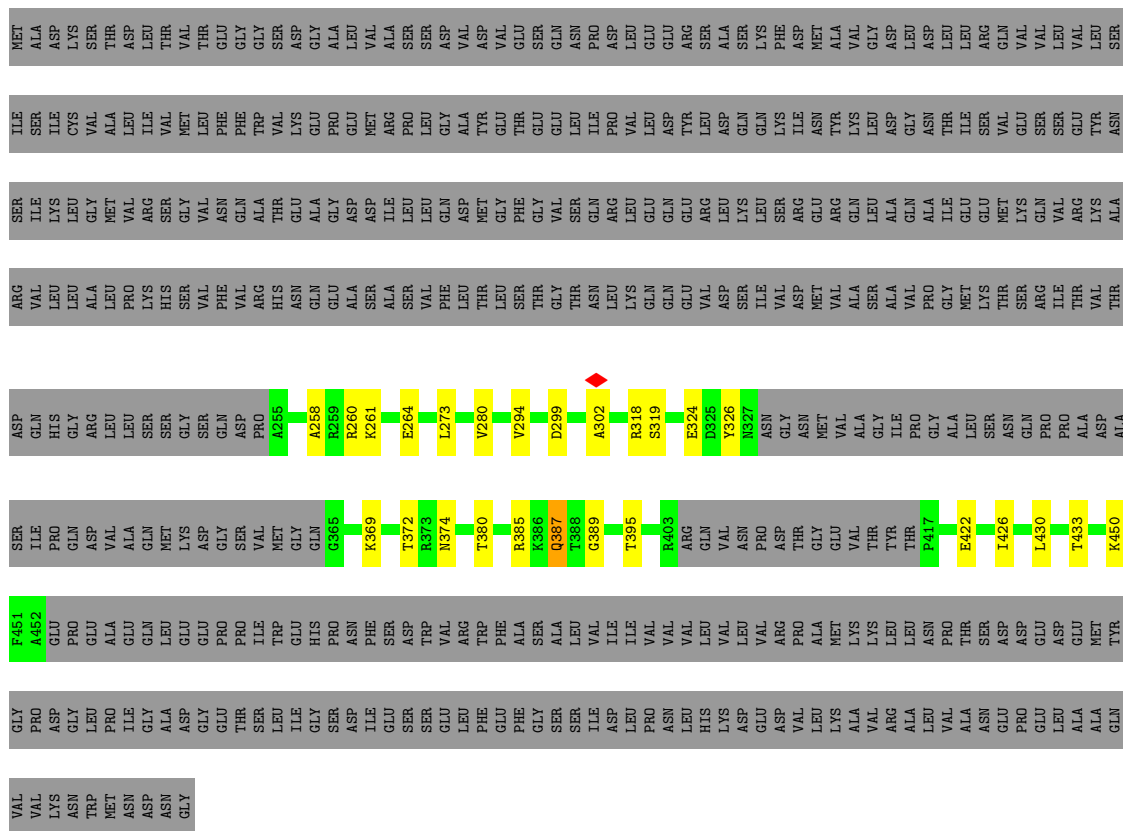

• Molecule 7: Flagellar M-ring protein

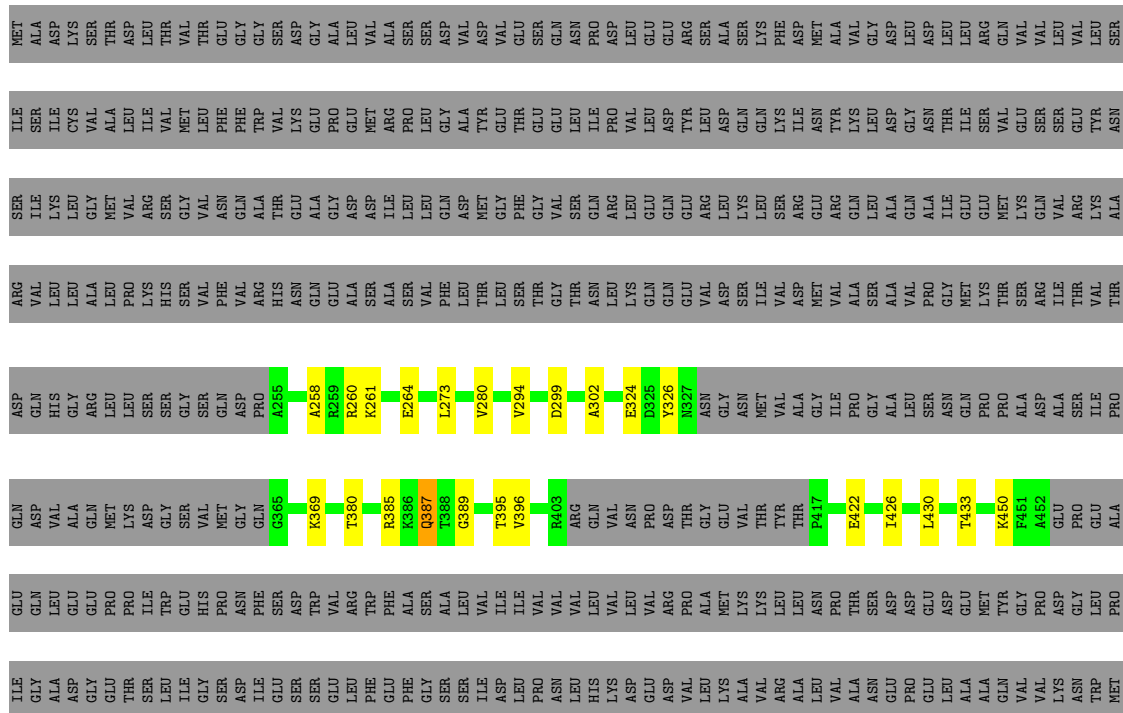

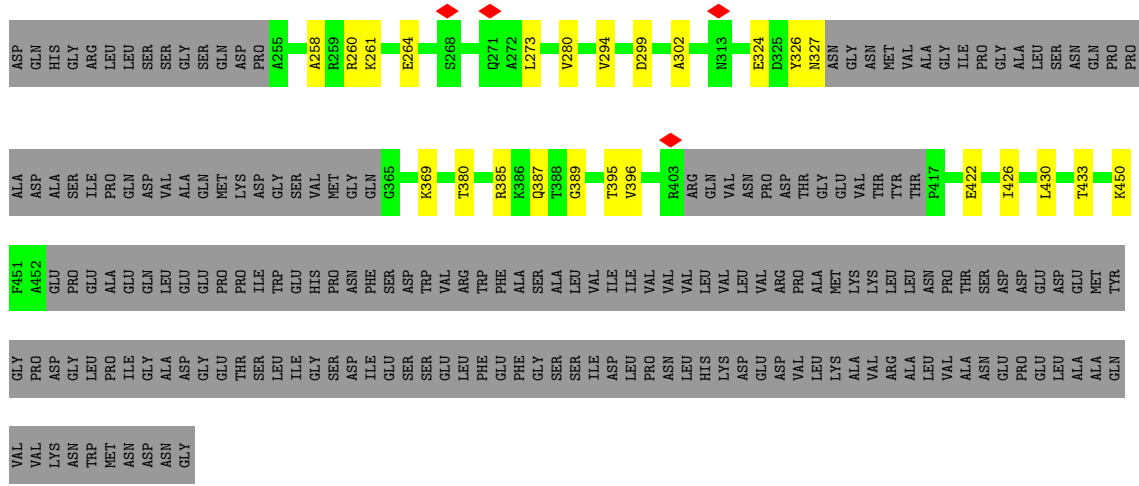

• Molecule 7: Flagellar M-ring protein

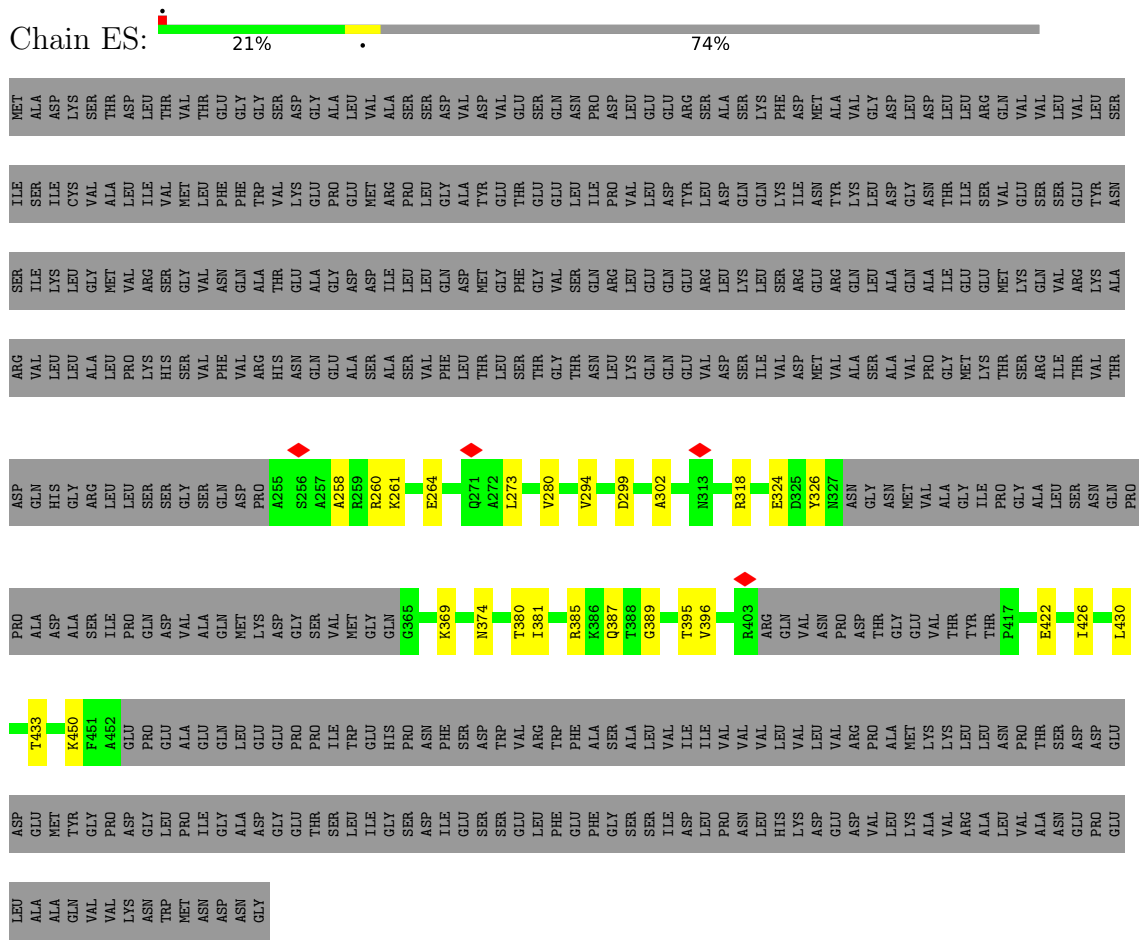

• Molecule 7: Flagellar M-ring protein

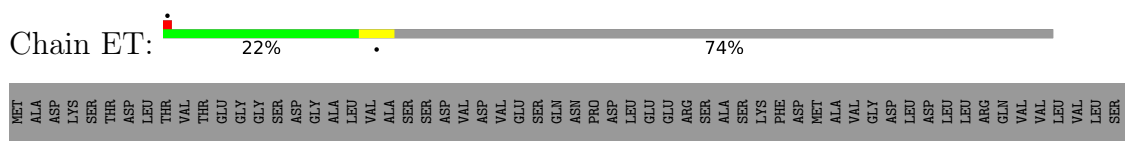

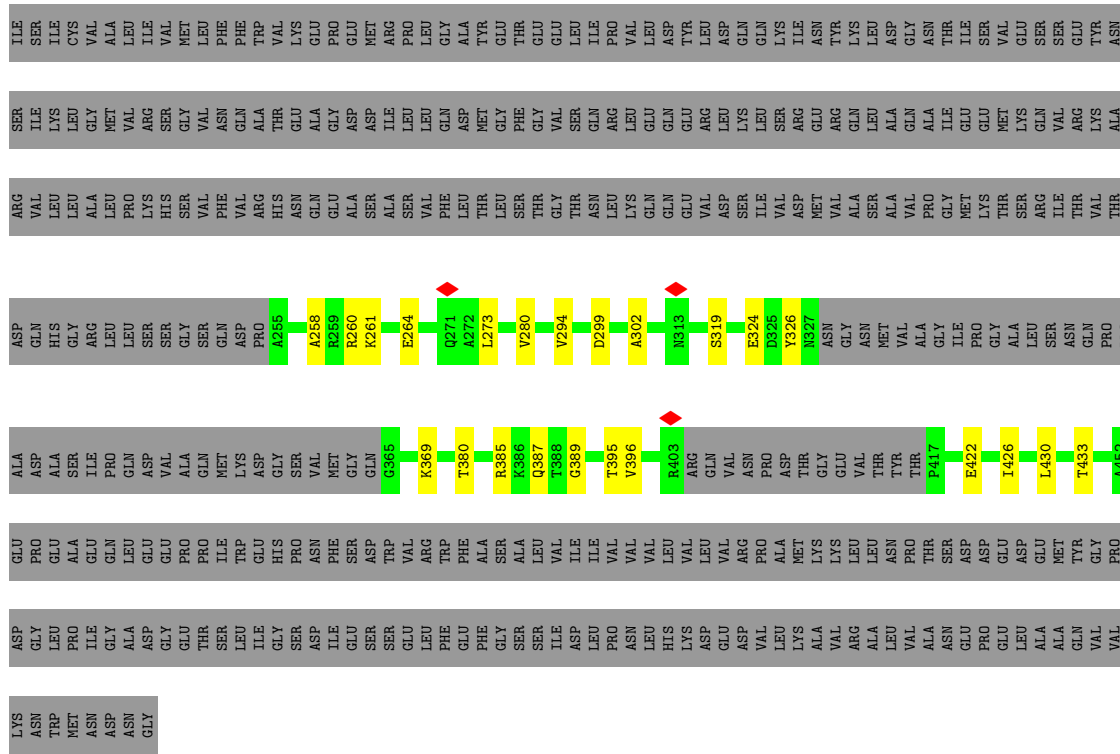

● Molecule 7: Flagellar M-ring protein

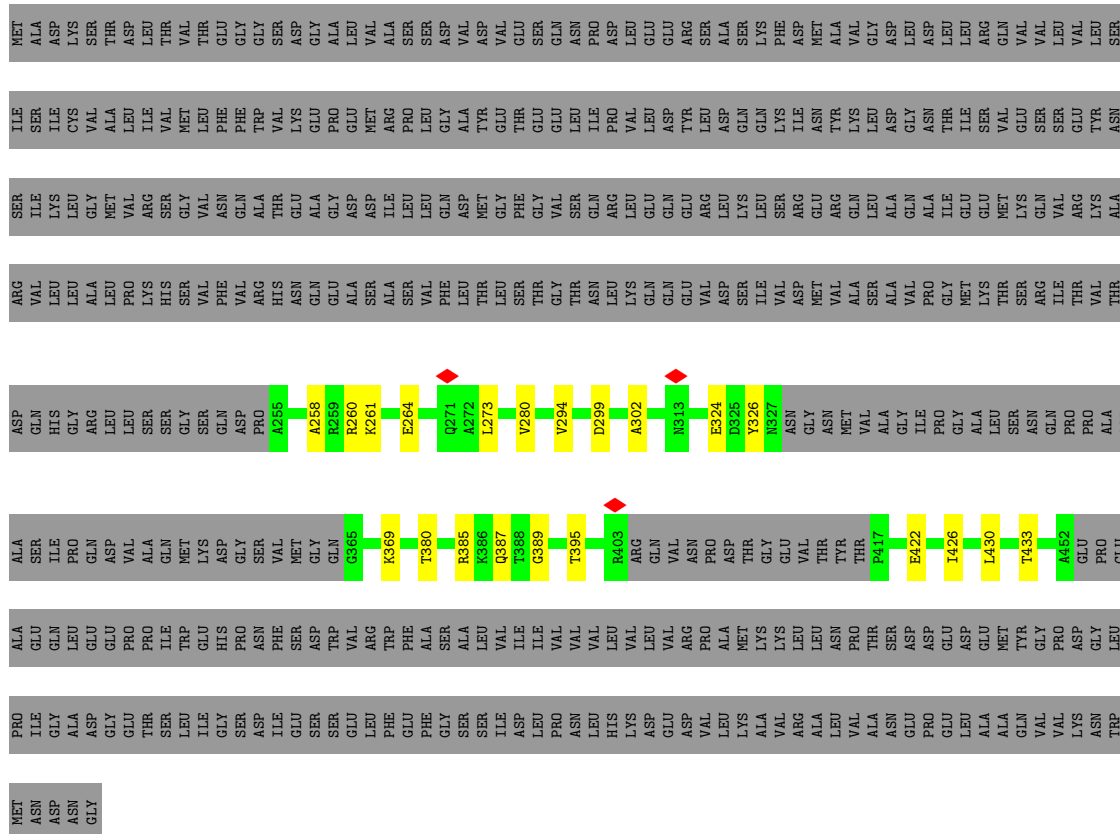

ALA
ALA
GLN
VAL
SER
VAL
LYS
VAL
ASN
TRP
MET
ASP
ASN
GLY

● Molecule 7: Flagellar M-ring protein

Chain Ej:  10% 7% .  82%

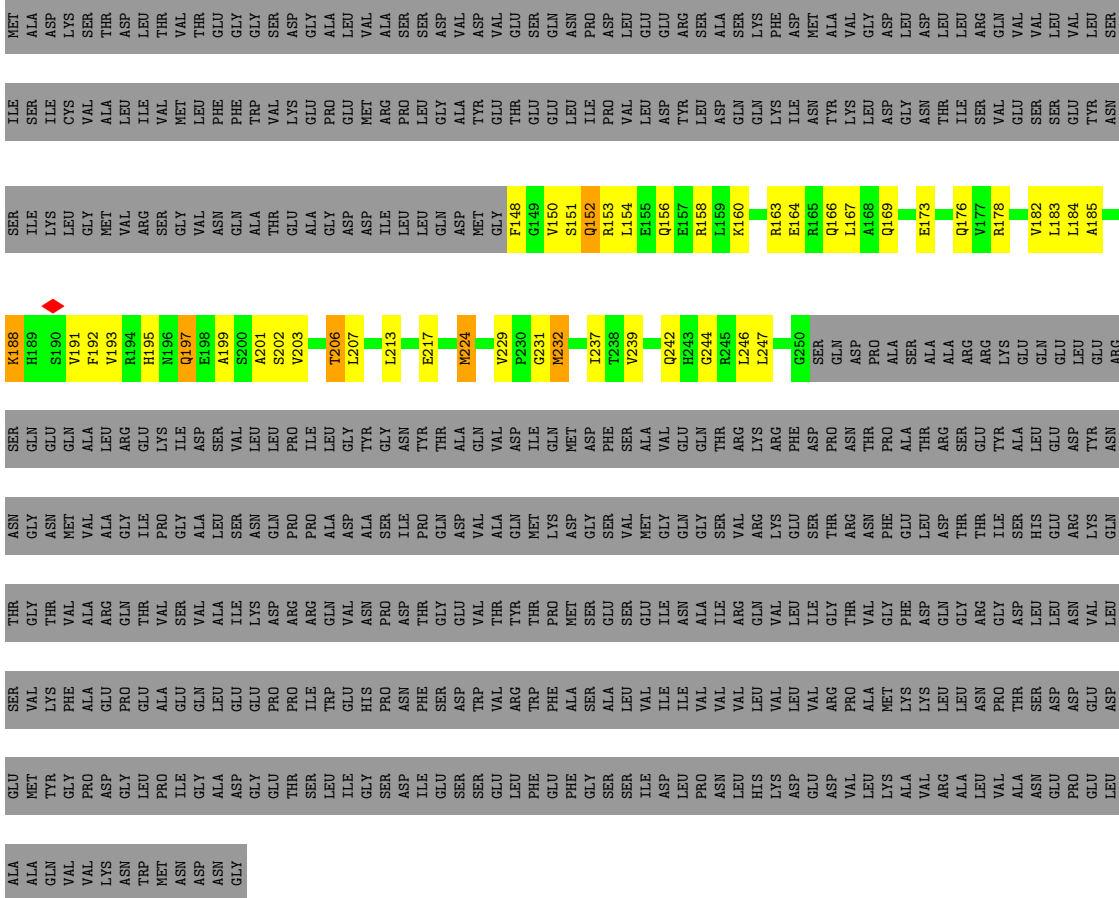

● Molecule 7: Flagellar M-ring protein

Chain Ek:  9% 6%  85%

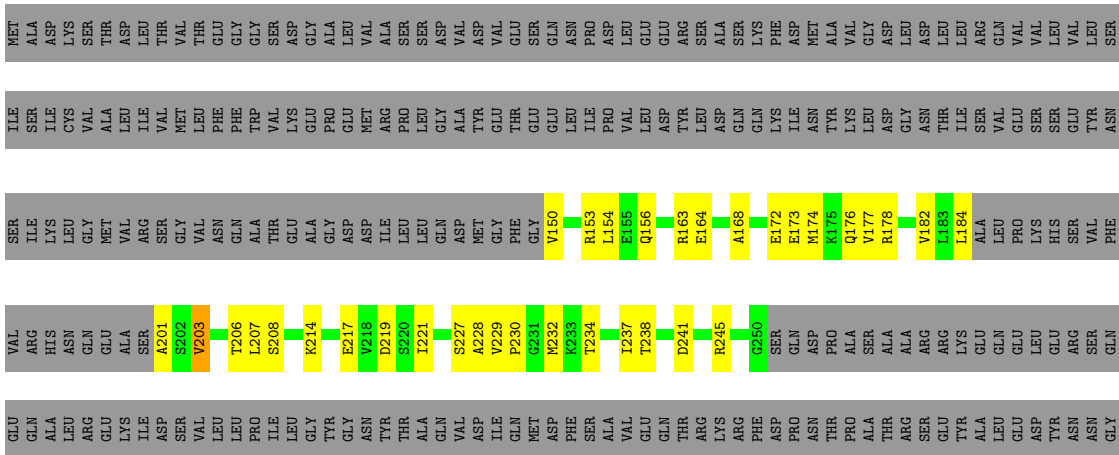

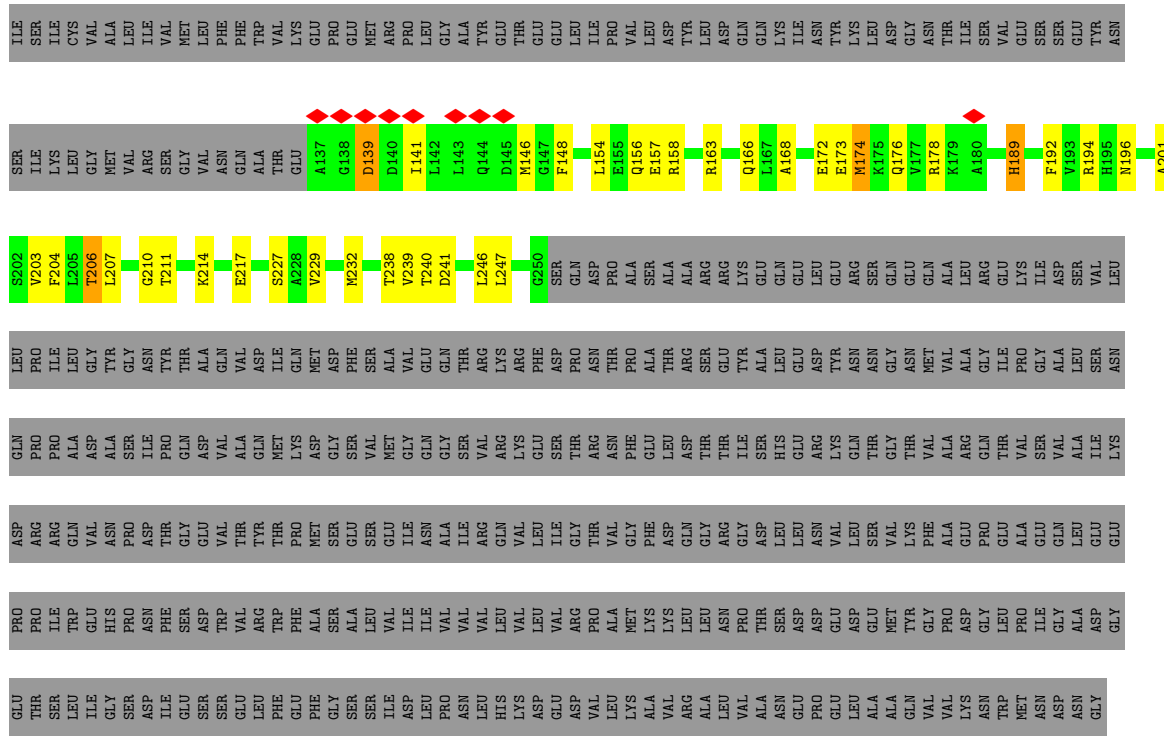

● Molecule 7: Flagellar M-ring protein

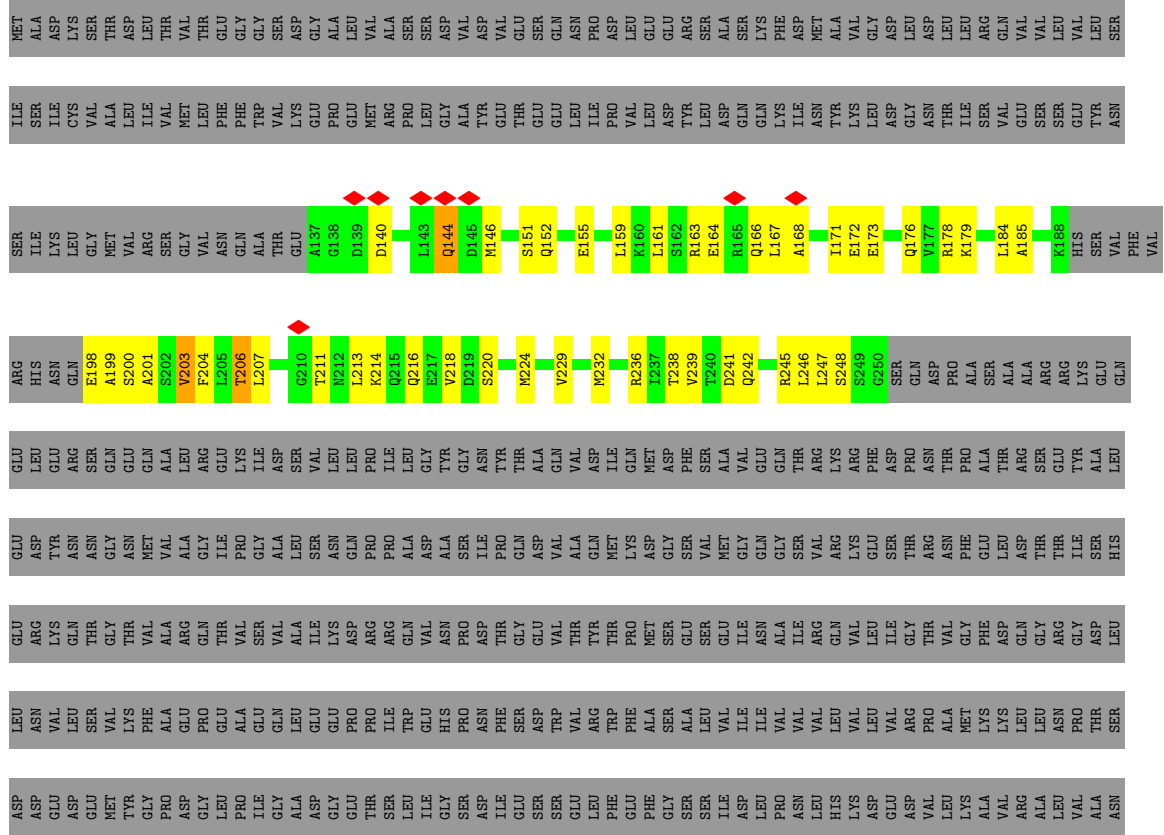

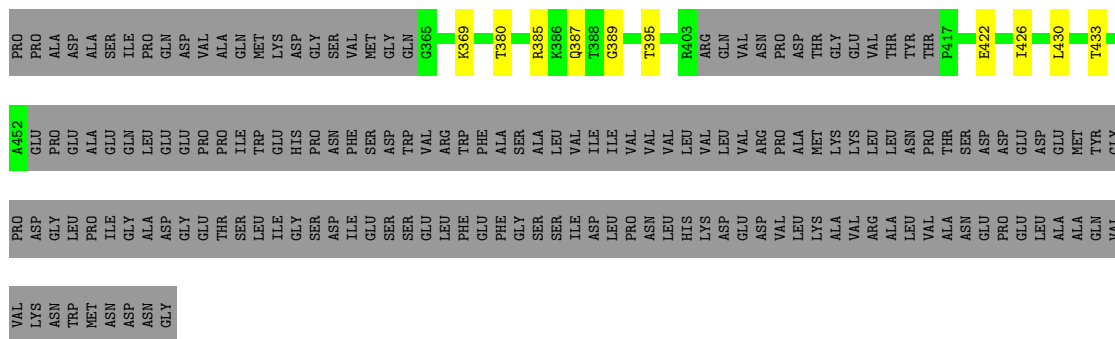

• Molecule 7: Flagellar M-ring protein



• Molecule 7: Flagellar M-ring protein

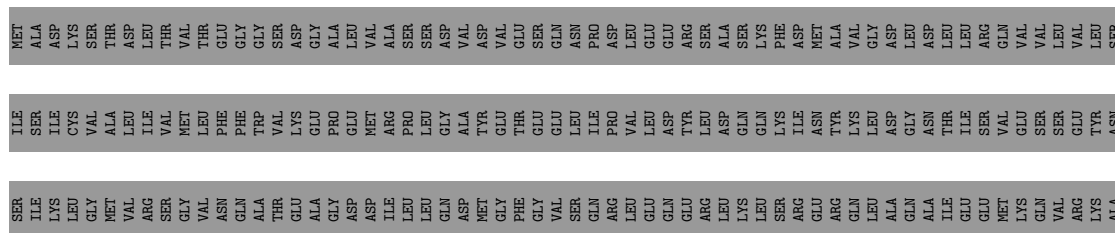

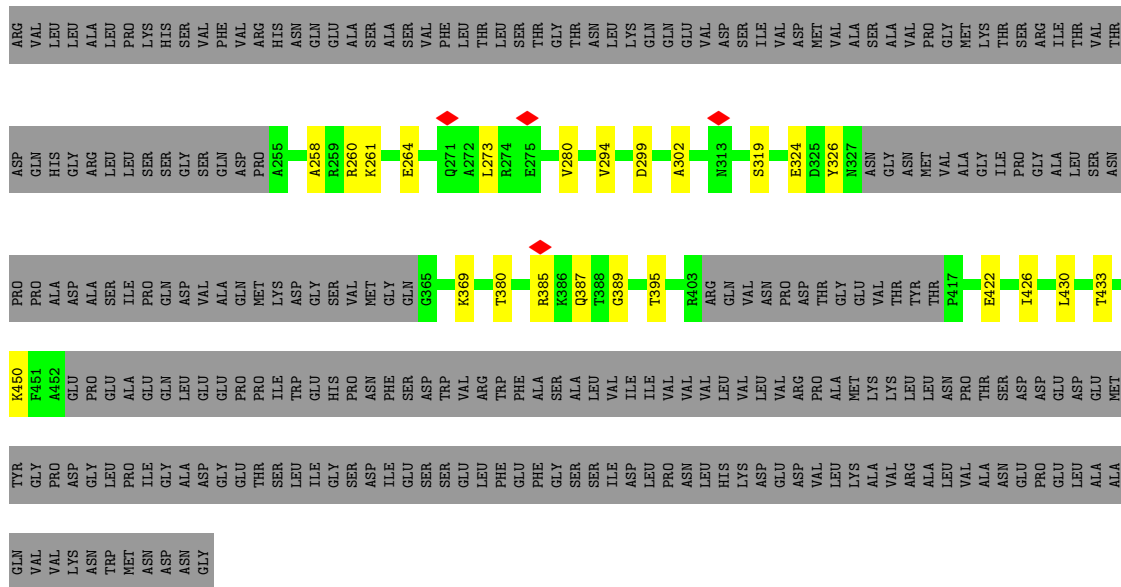

• Molecule 7: Flagellar M-ring protein

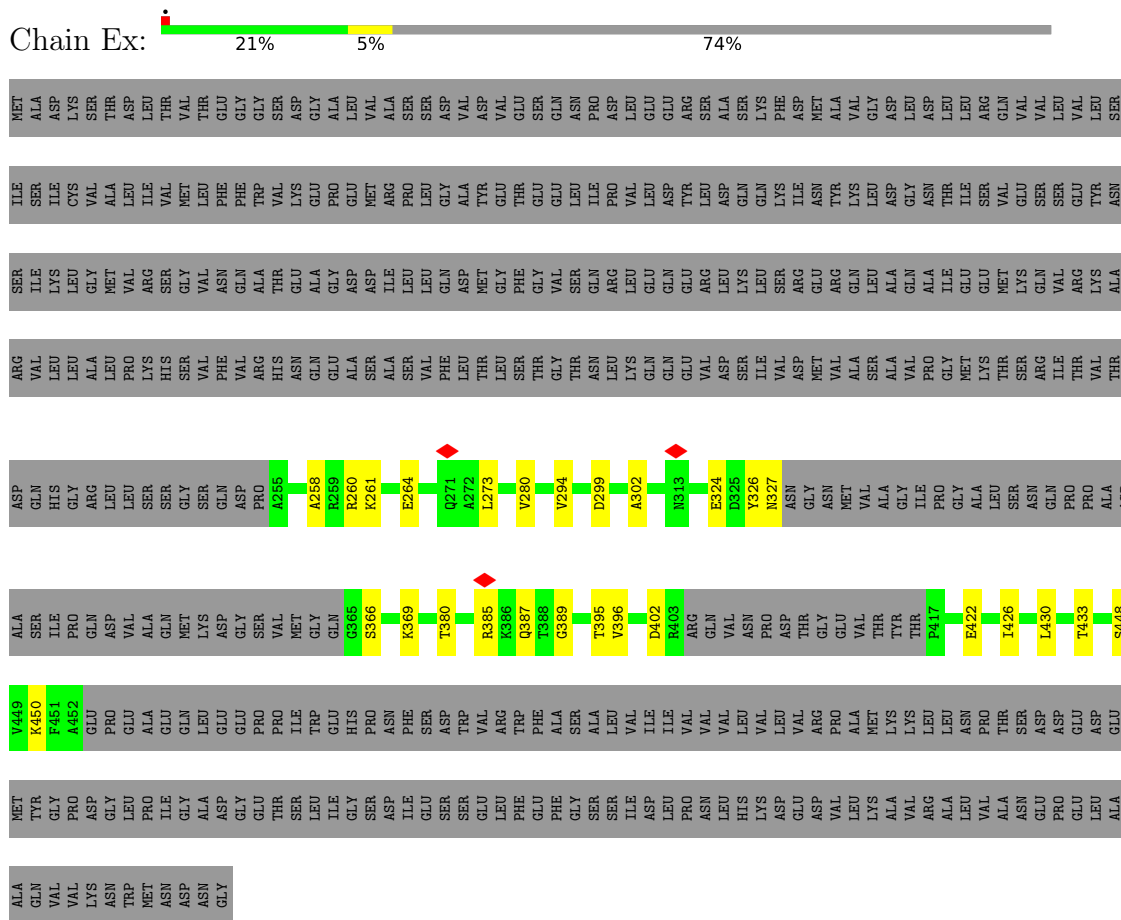

• Molecule 7: Flagellar M-ring protein



• Molecule 8: Flagellar basal body rod protein FlgB

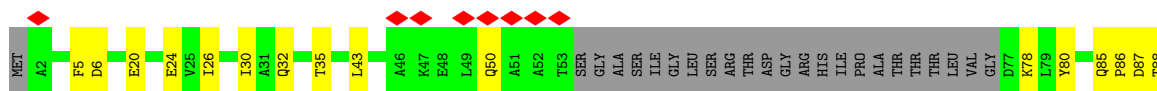

• Molecule 8: Flagellar basal body rod protein FlgB

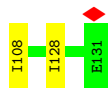
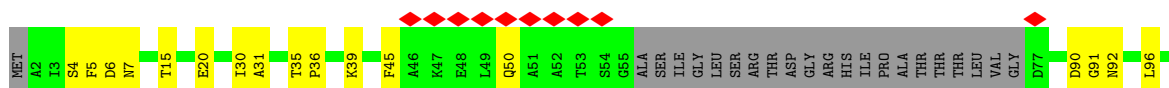

• Molecule 8: Flagellar basal body rod protein FlgB

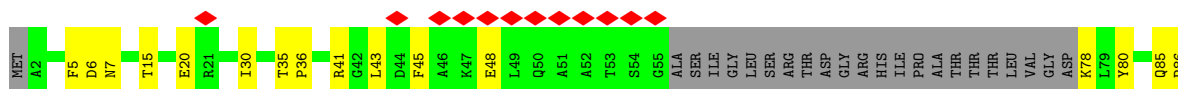

• Molecule 8: Flagellar basal body rod protein FlgB

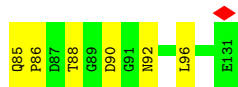
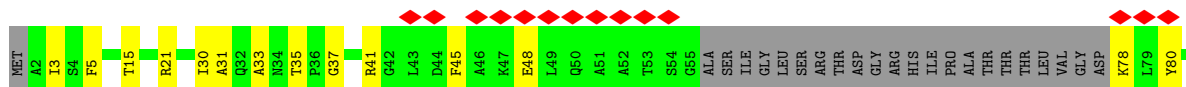

• Molecule 9: Flagellar basal-body rod protein FlgC

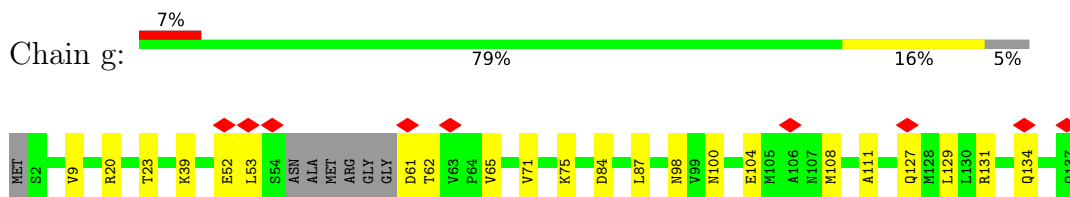

• Molecule 9: Flagellar basal-body rod protein FlgC

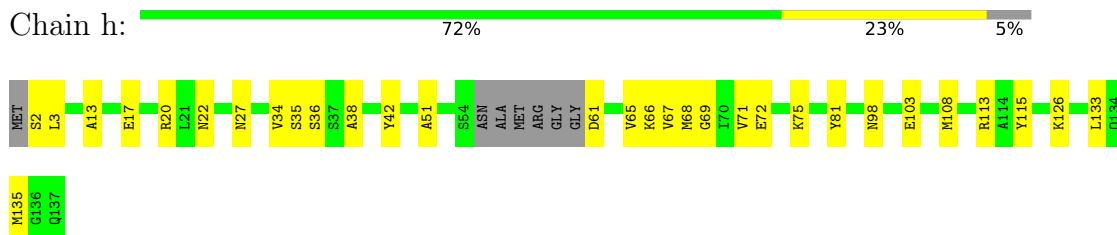

• Molecule 9: Flagellar basal-body rod protein FlgC

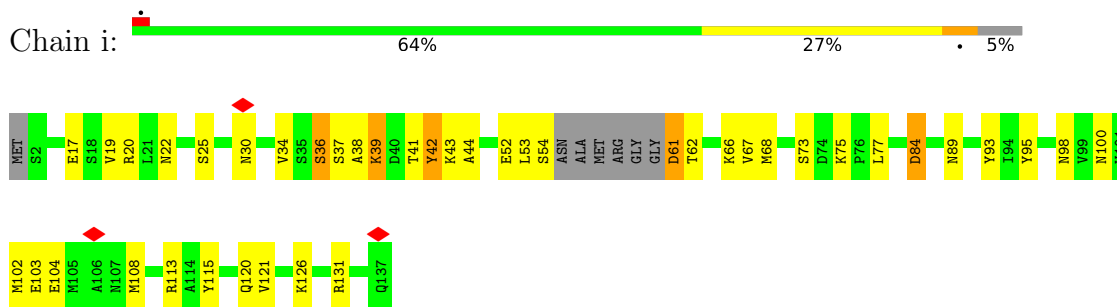

• Molecule 9: Flagellar basal-body rod protein FlgC

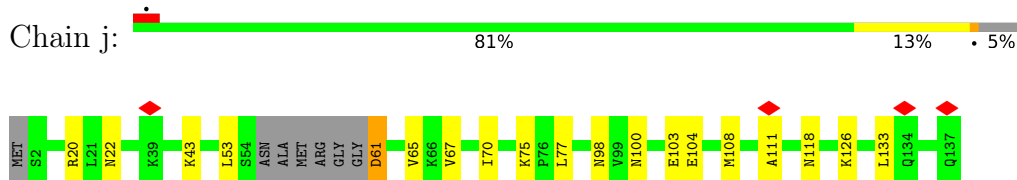

• Molecule 9: Flagellar basal-body rod protein FlgC

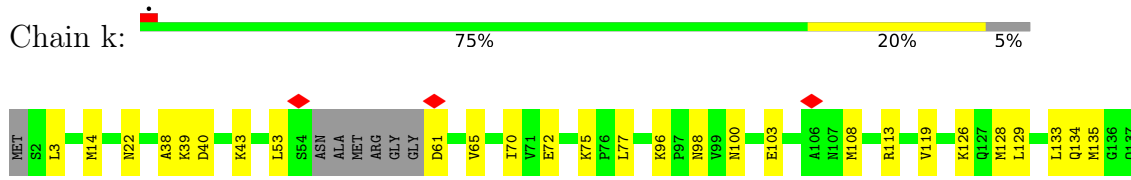

• Molecule 9: Flagellar basal-body rod protein FlgC

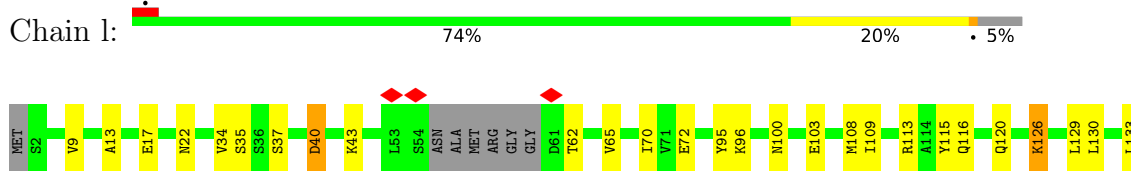



• Molecule 10: Flagellar basal-body rod protein FlgF

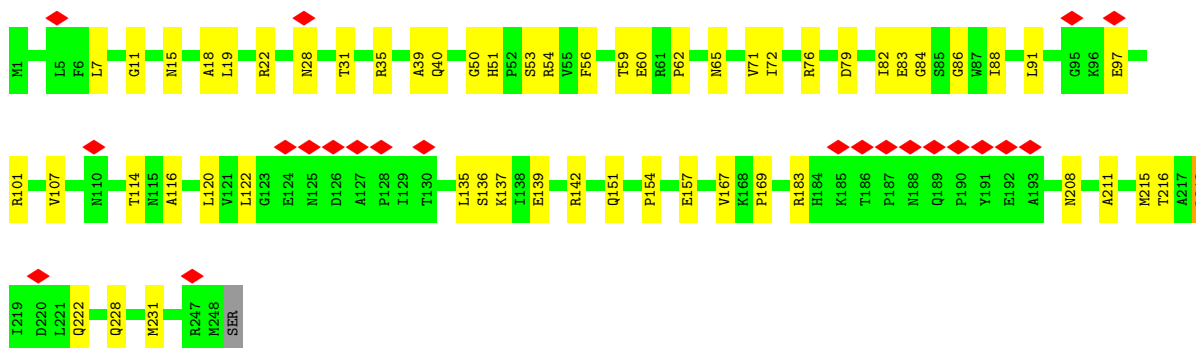
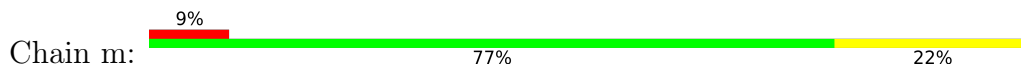

• Molecule 10: Flagellar basal-body rod protein FlgF

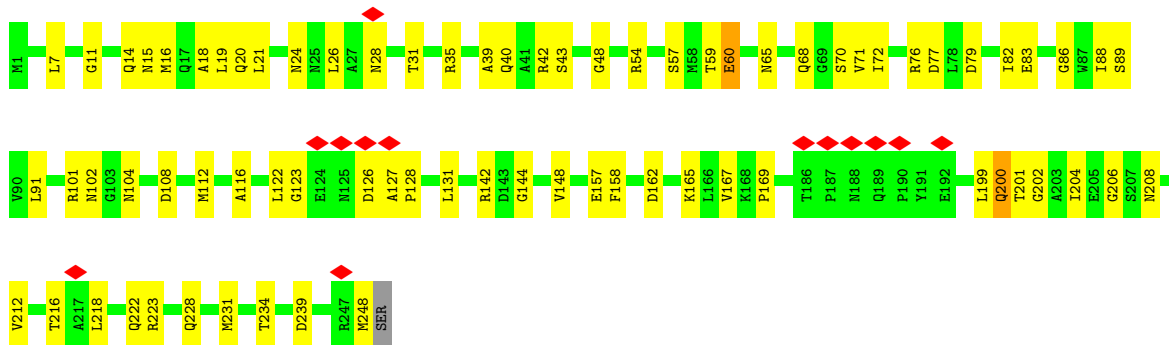

• Molecule 10: Flagellar basal-body rod protein FlgF

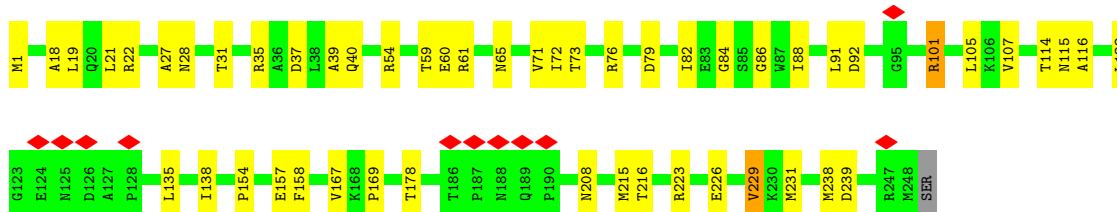
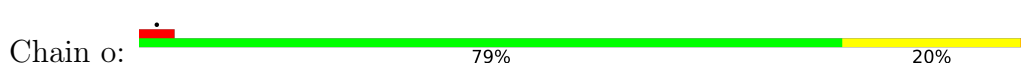

• Molecule 10: Flagellar basal-body rod protein FlgF

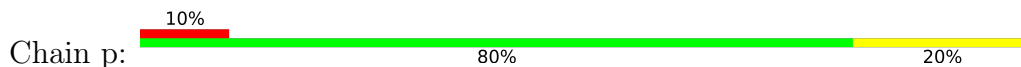

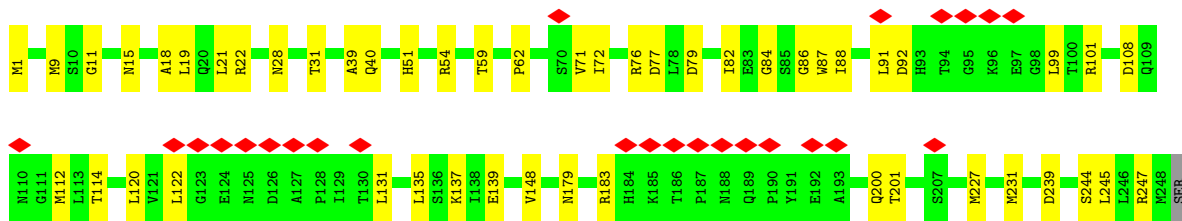

• Molecule 10: Flagellar basal-body rod protein FlgF

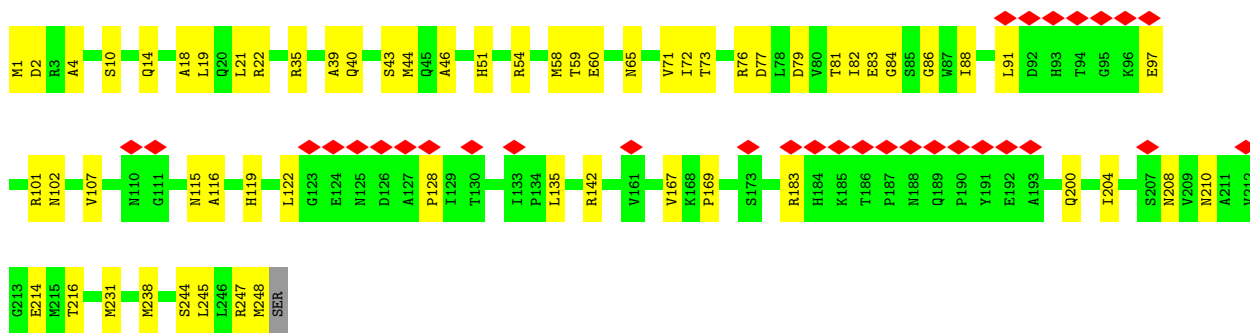
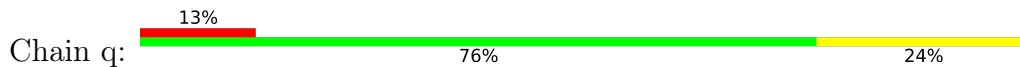

• Molecule 11: Flagellar hook-basal body complex protein FliE

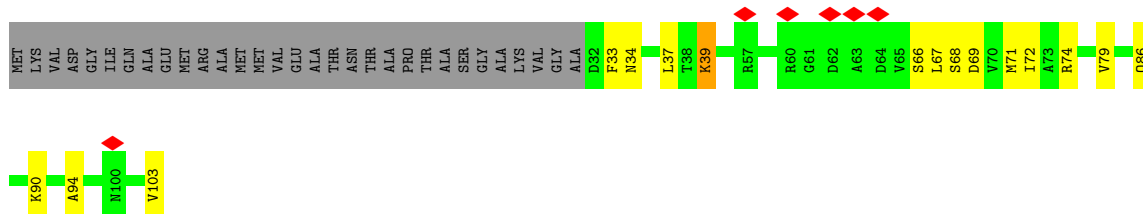

• Molecule 11: Flagellar hook-basal body complex protein FliE

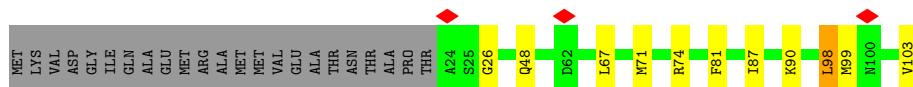

• Molecule 11: Flagellar hook-basal body complex protein FliE

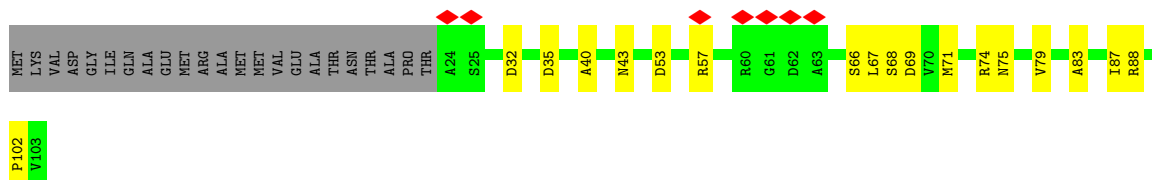

• Molecule 11: Flagellar hook-basal body complex protein FliE

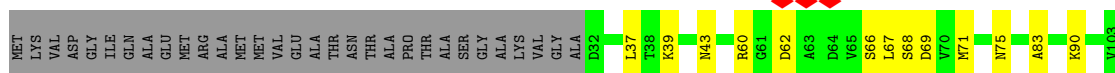

• Molecule 11: Flagellar hook-basal body complex protein FliE



• Molecule 11: Flagellar hook-basal body complex protein FliE

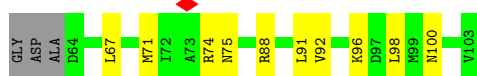
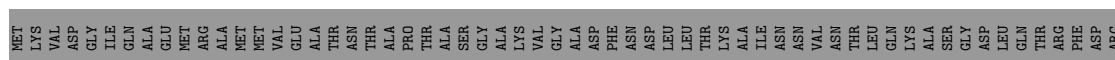

• Molecule 12: Flagellar biosynthetic protein FlhB

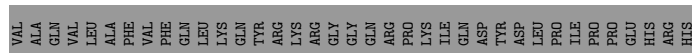
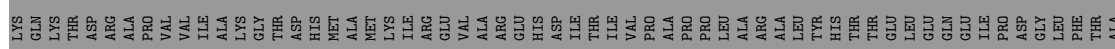
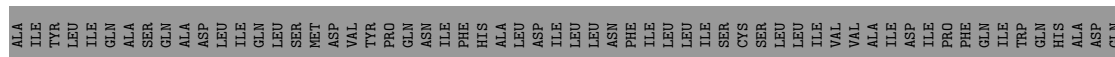
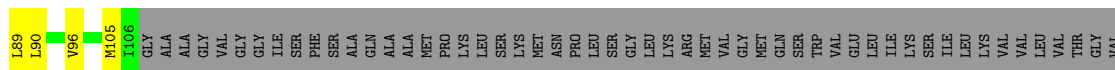
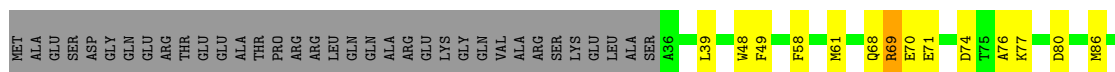

• Molecule 13: Flagella basal-body protein

Chain B7: 

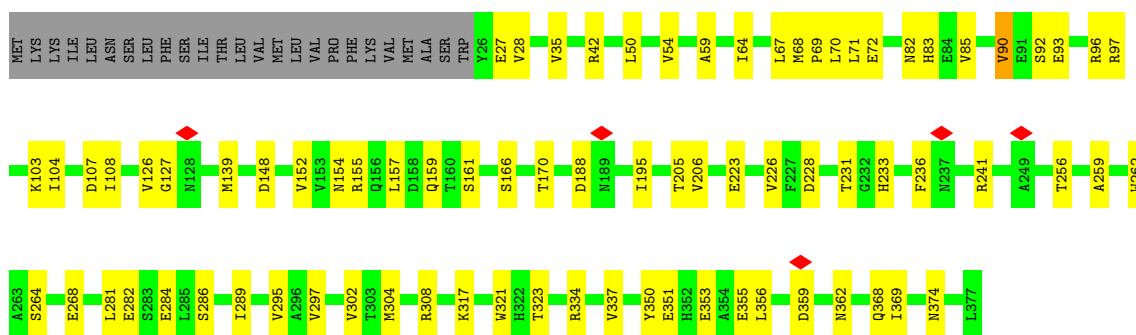

• Molecule 13: Flagella basal-body protein

Chain CB: 

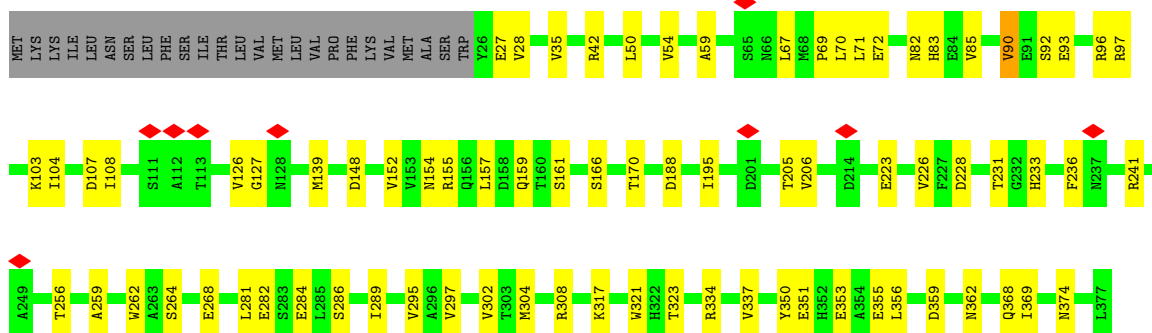

• Molecule 13: Flagella basal-body protein

Chain CJ: 

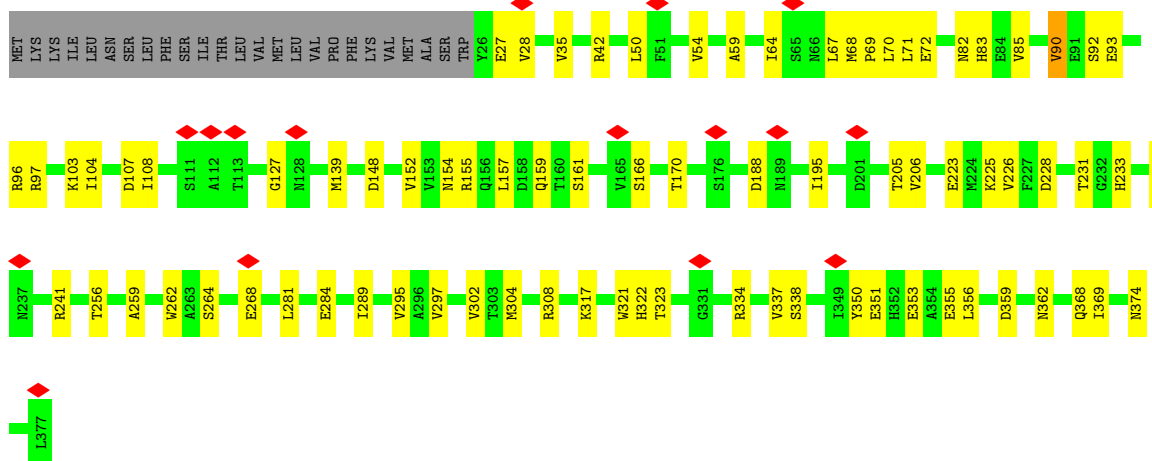

• Molecule 13: Flagella basal-body protein

Chain A8: 

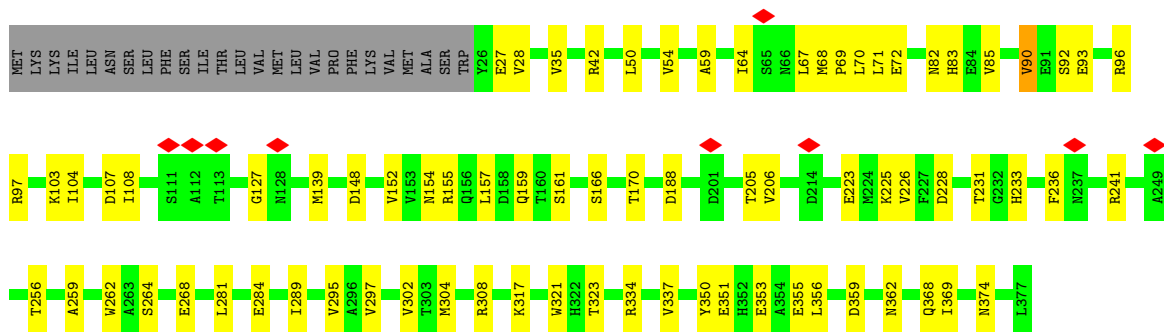

• Molecule 13: Flagella basal-body protein

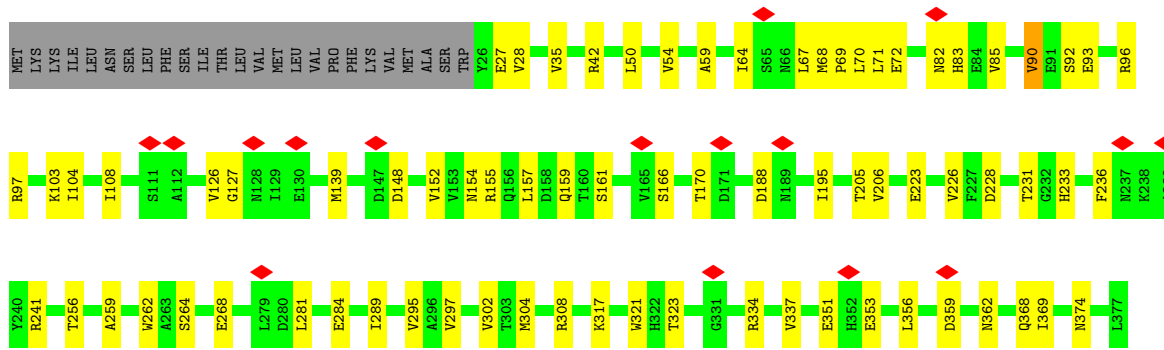
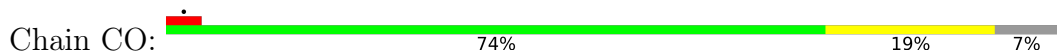

• Molecule 13: Flagella basal-body protein

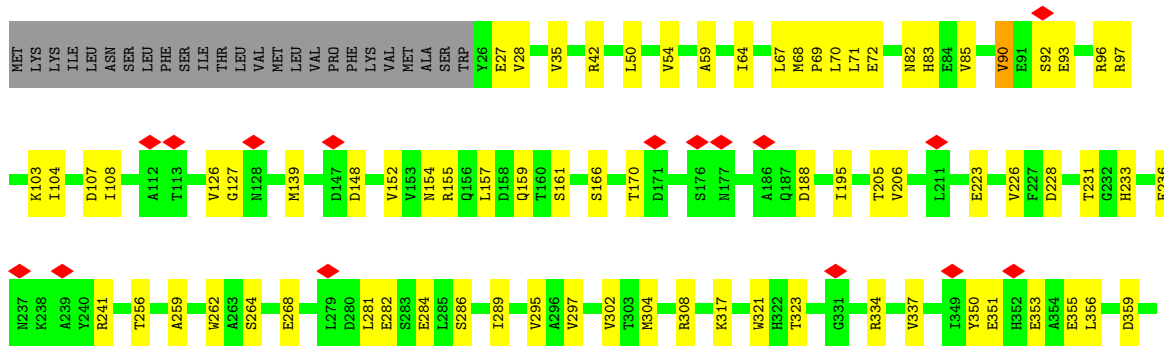
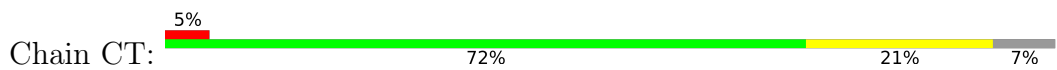

• Molecule 13: Flagella basal-body protein

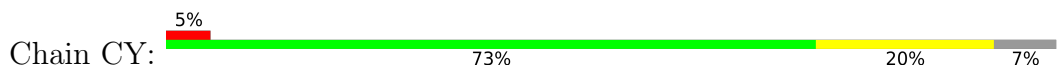

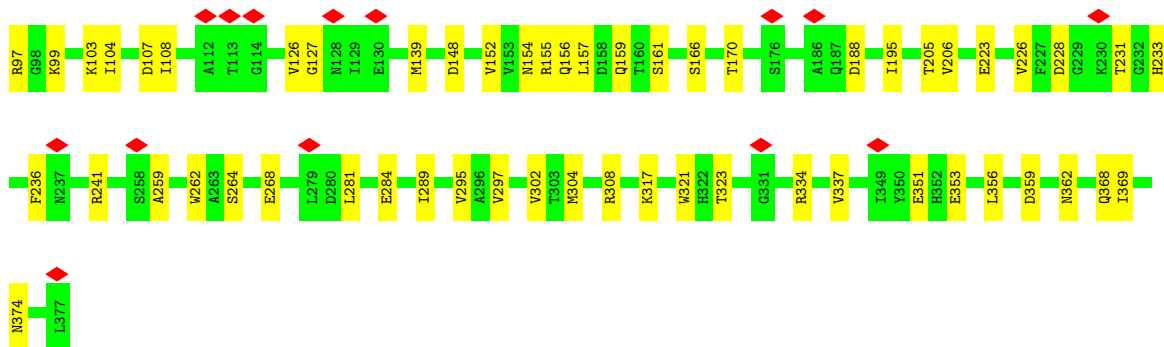

• Molecule 13: Flagella basal-body protein

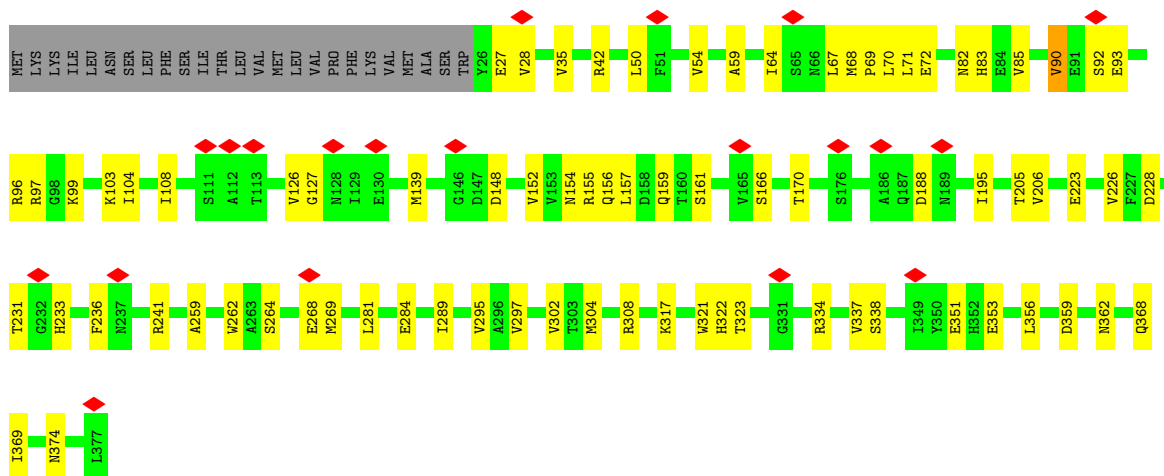

• Molecule 13: Flagella basal-body protein

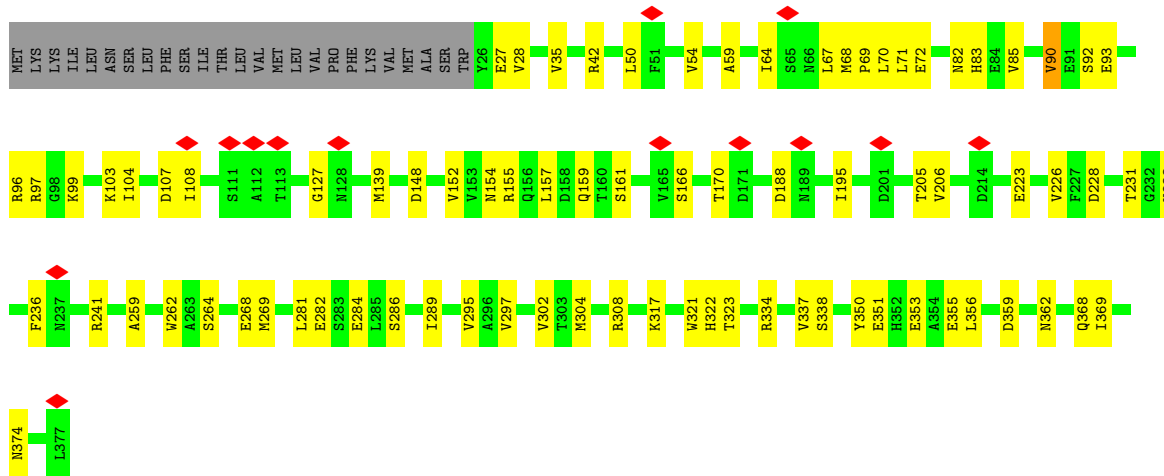

• Molecule 13: Flagella basal-body protein

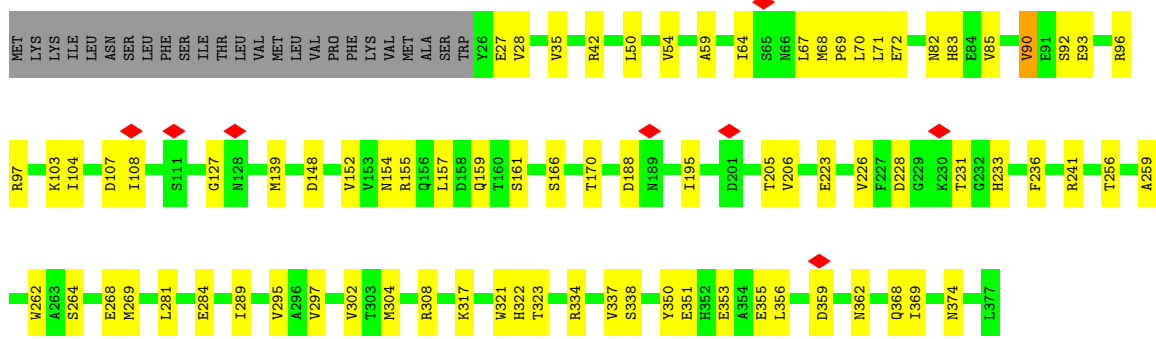
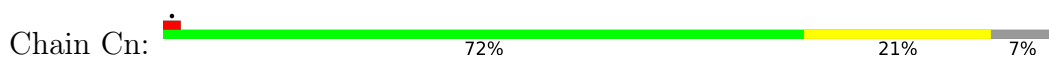

• Molecule 13: Flagella basal-body protein

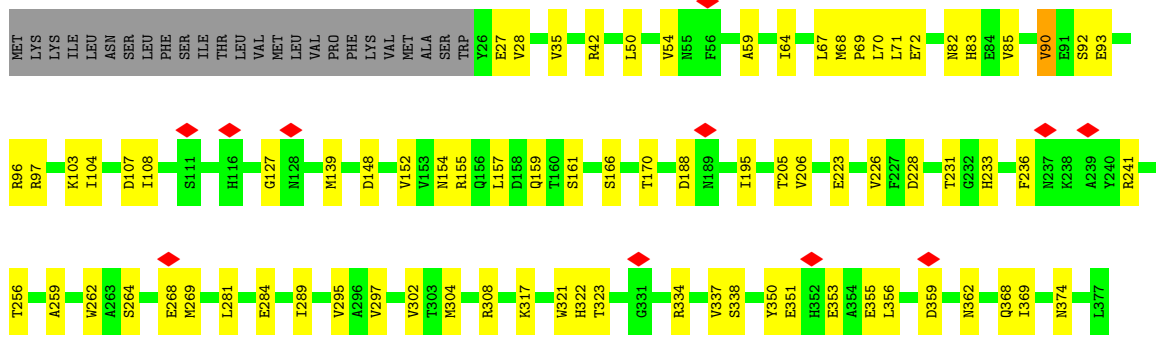
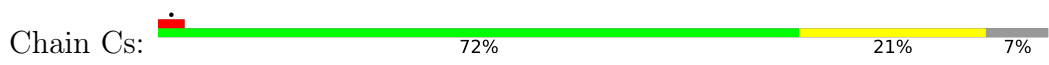

• Molecule 13: Flagella basal-body protein

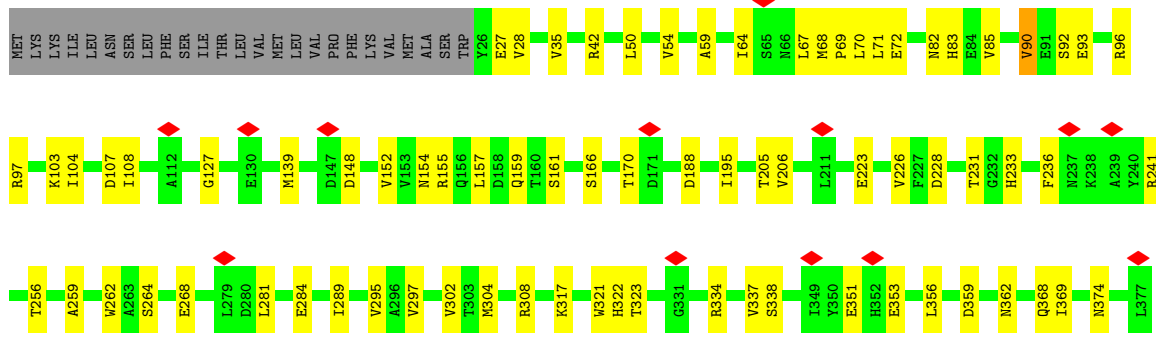
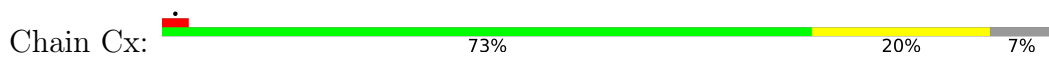

• Molecule 13: Flagella basal-body protein

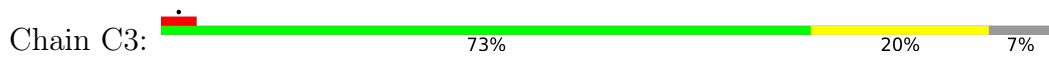

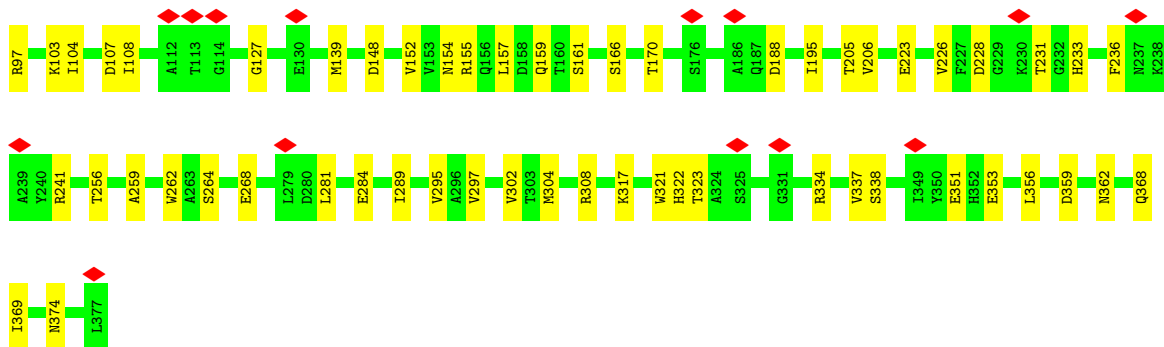

• Molecule 13: Flagella basal-body protein

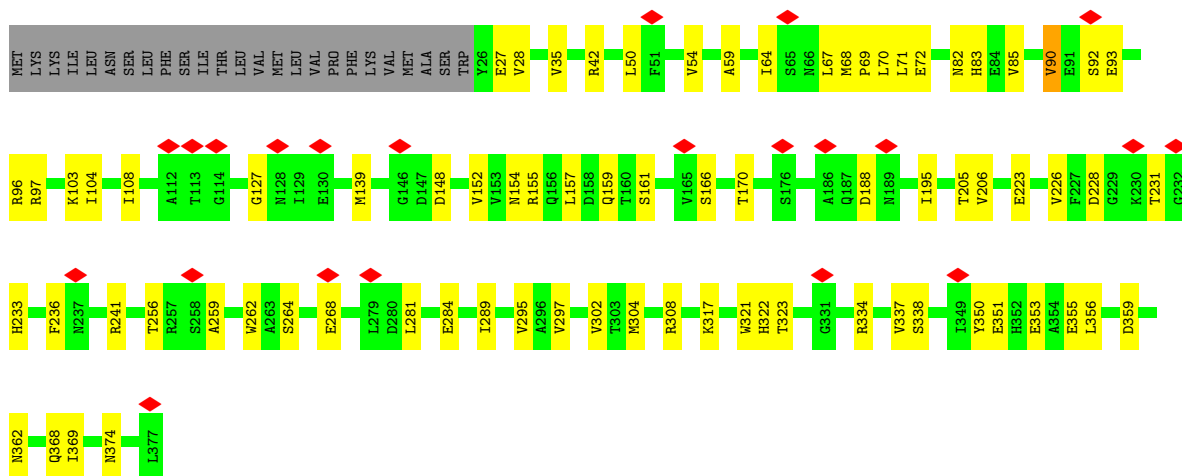
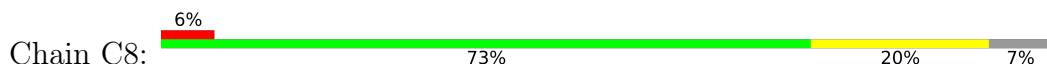

• Molecule 13: Flagella basal-body protein

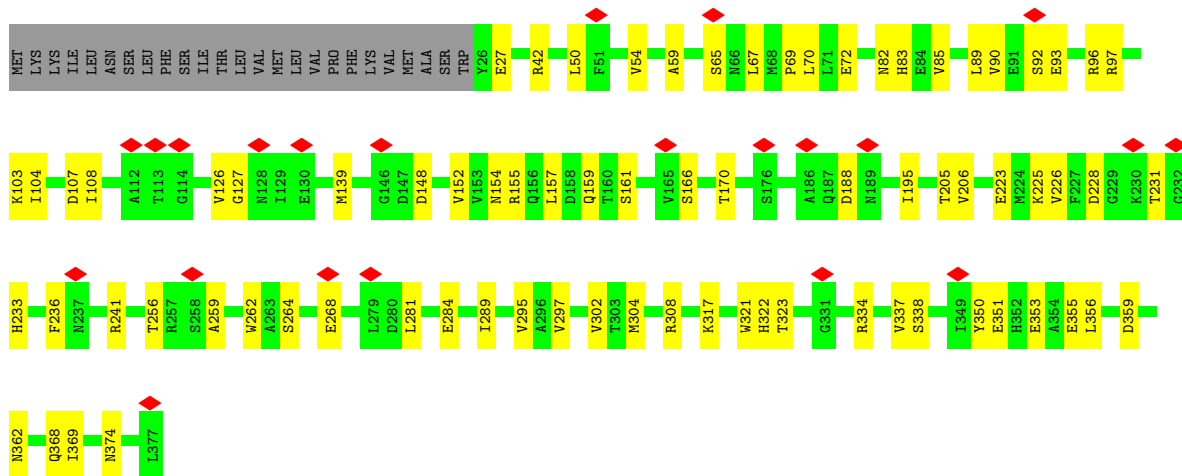
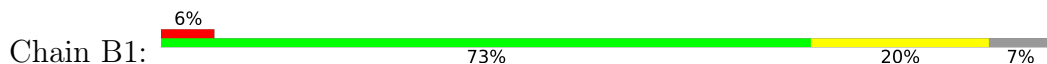

• Molecule 13: Flagella basal-body protein

Chain B6: 

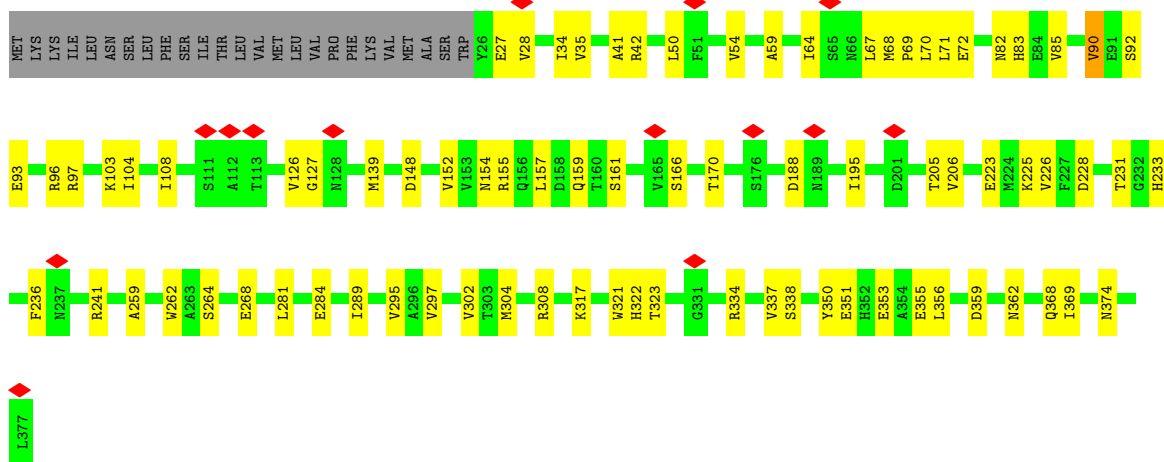

• Molecule 13: Flagella basal-body protein

Chain BC: 

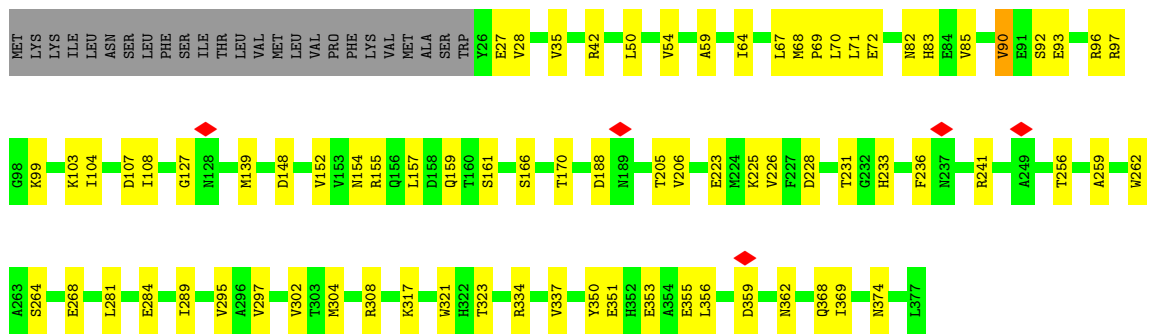

• Molecule 13: Flagella basal-body protein

Chain BH: 

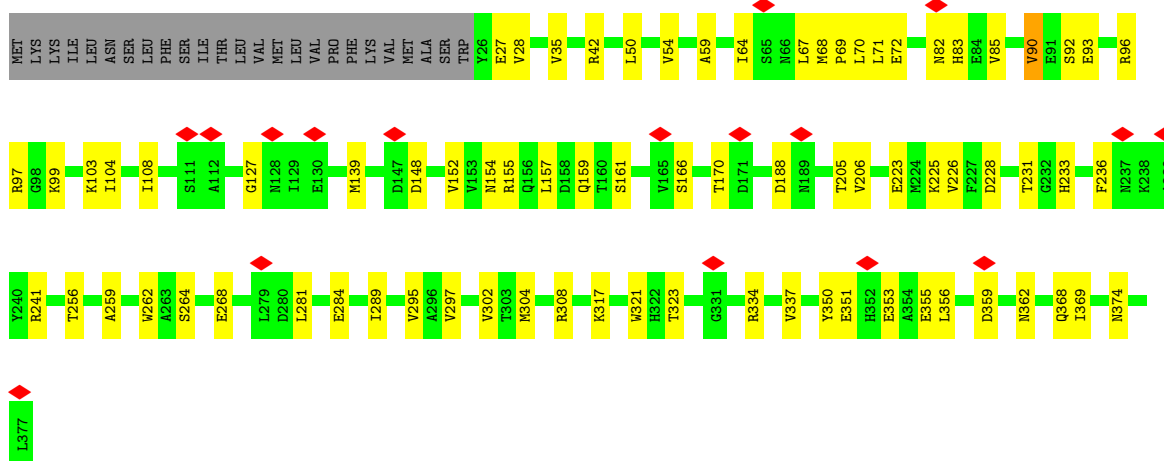

• Molecule 13: Flagella basal-body protein

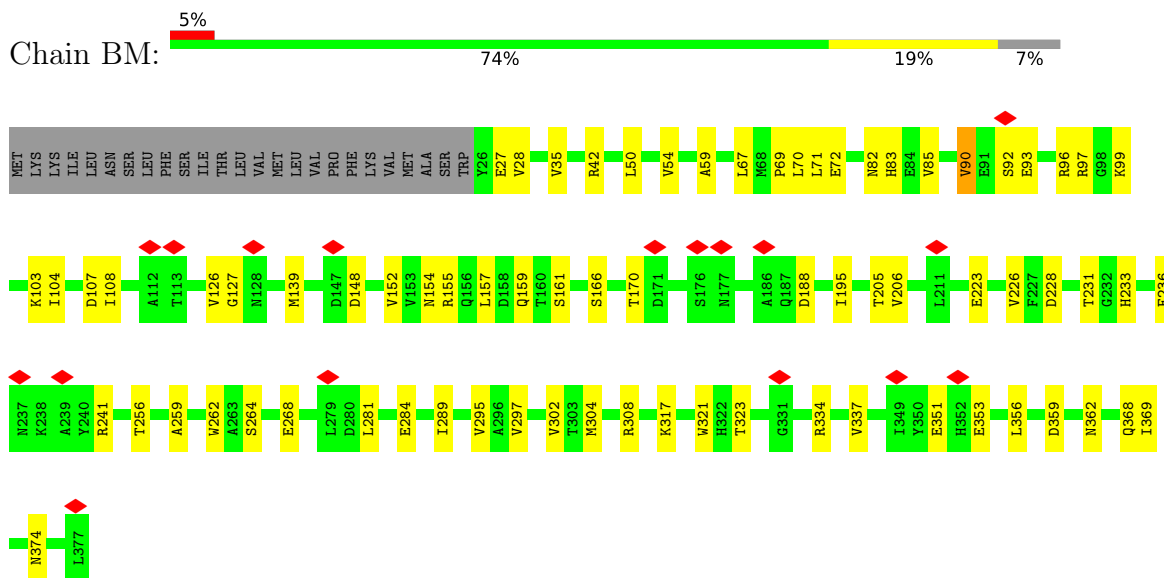

• Molecule 13: Flagella basal-body protein

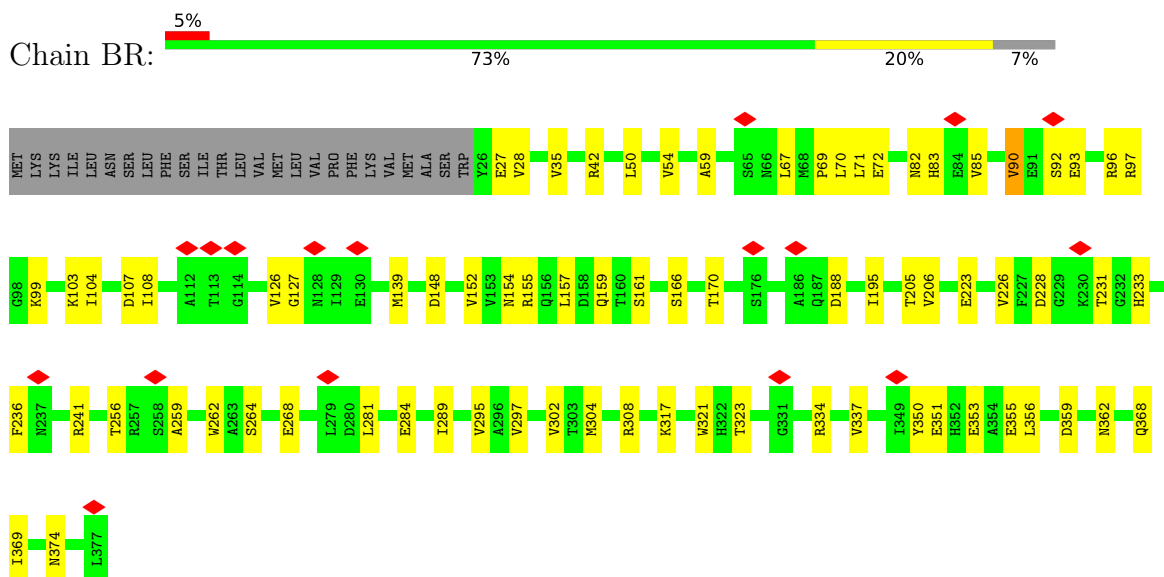

• Molecule 13: Flagella basal-body protein

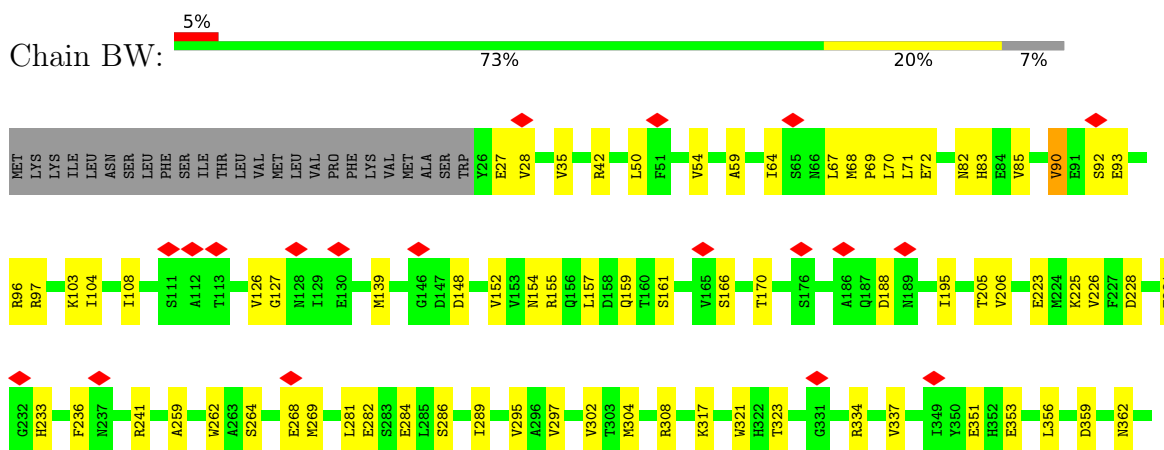

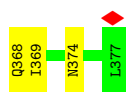

• Molecule 13: Flagella basal-body protein

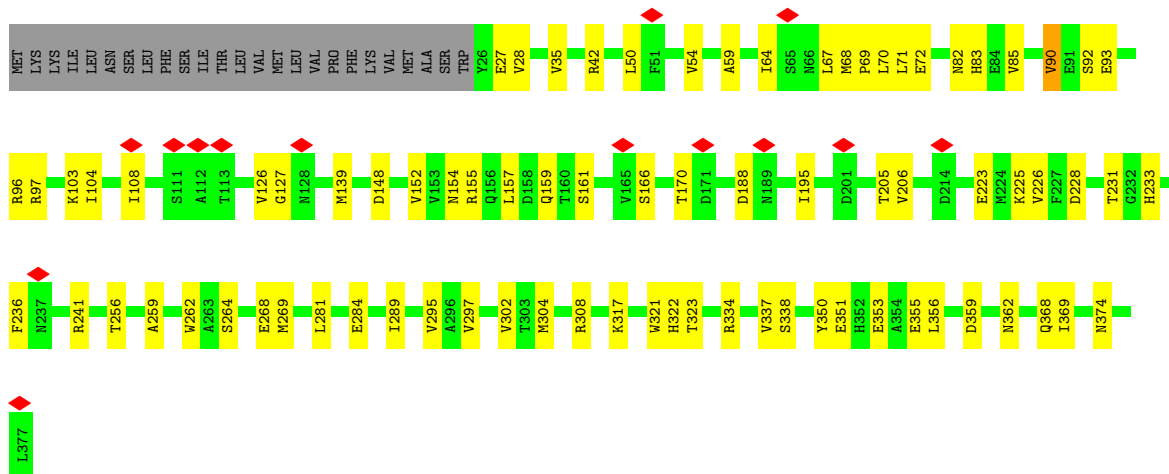

• Molecule 13: Flagella basal-body protein

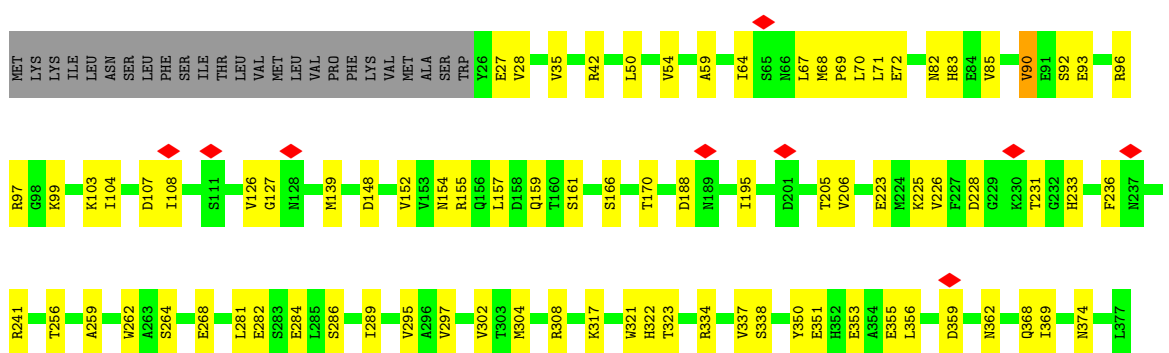

• Molecule 13: Flagella basal-body protein

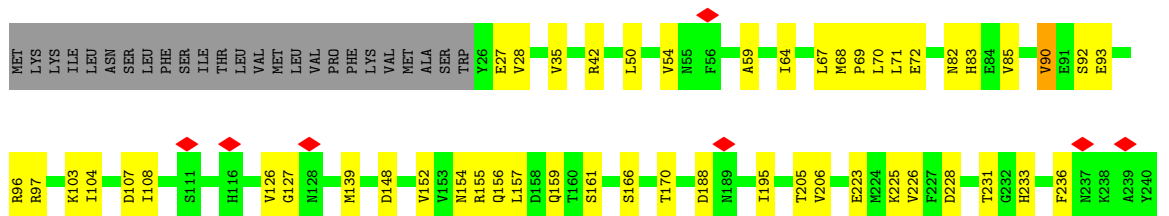



• Molecule 13: Flagella basal-body protein

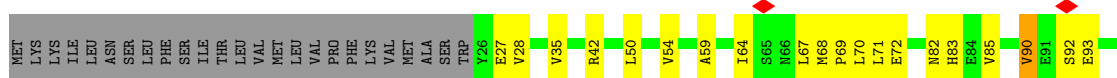
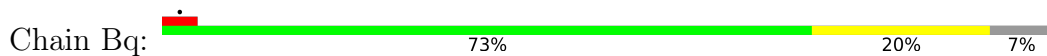

• Molecule 13: Flagella basal-body protein

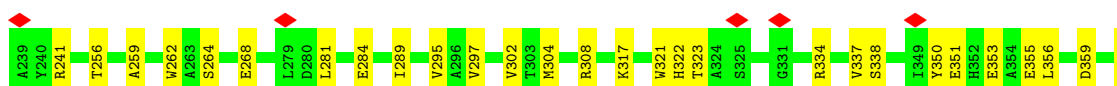
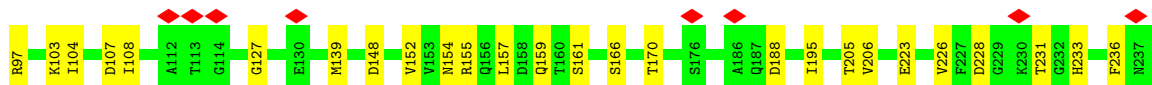
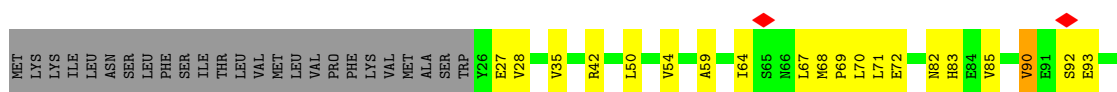
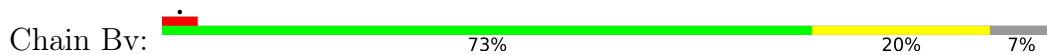

• Molecule 14: FlgH

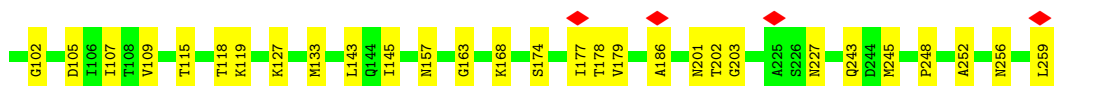

• Molecule 14: FlgH

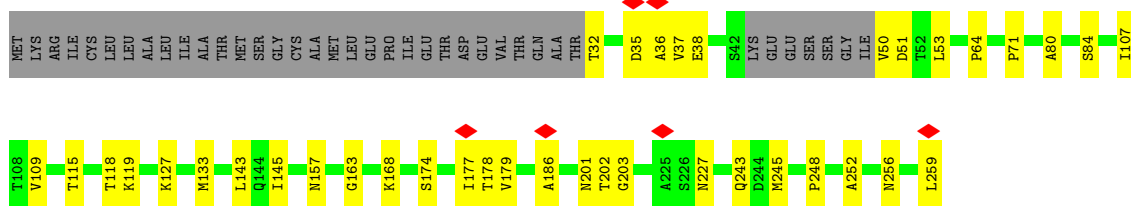

• Molecule 14: FlgH

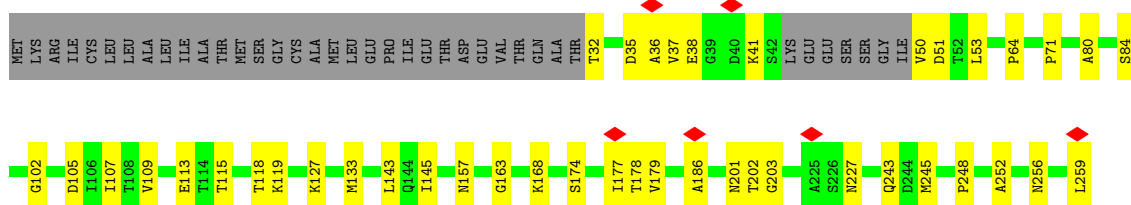

• Molecule 14: FlgH

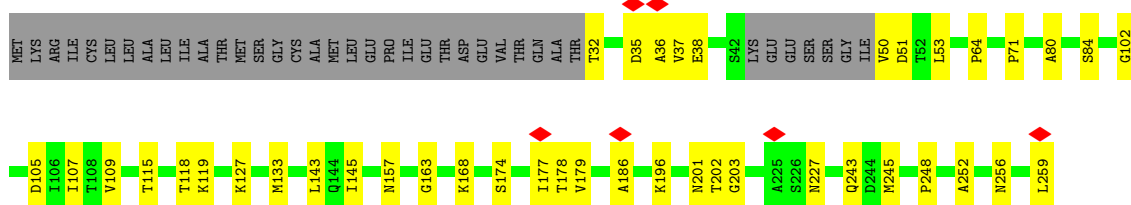

• Molecule 14: FlgH

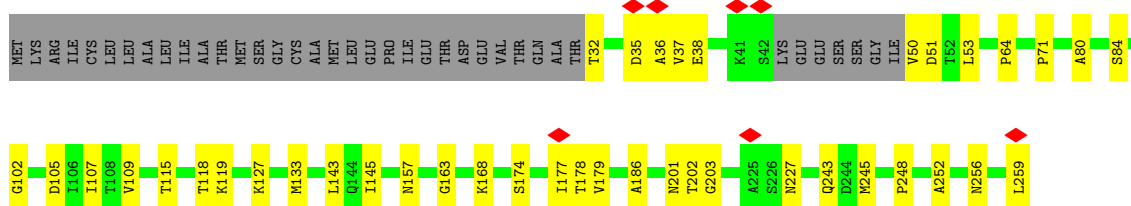

• Molecule 14: FlgH



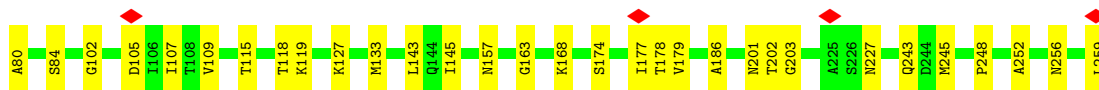

• Molecule 14: FlgH

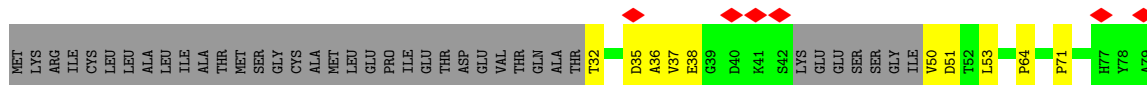

• Molecule 14: FlgH

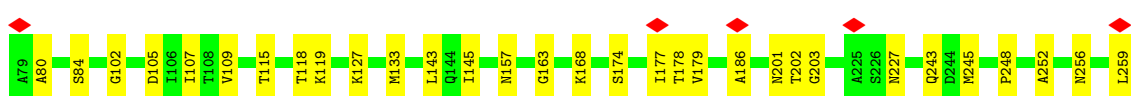
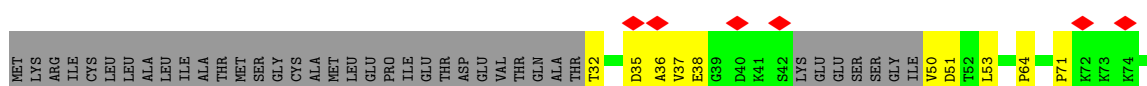

• Molecule 14: FlgH



• Molecule 14: FlgH

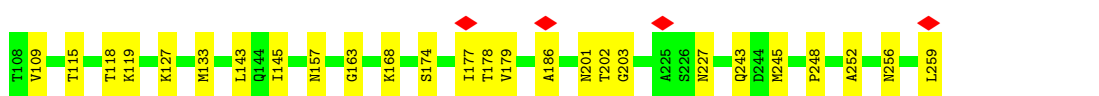
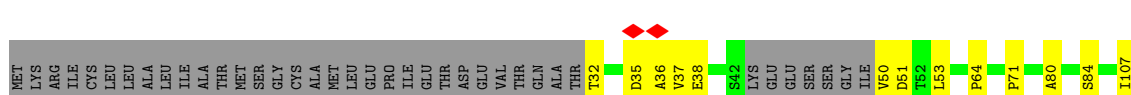

• Molecule 14: FlgH

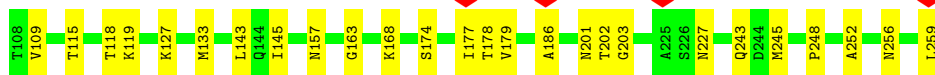
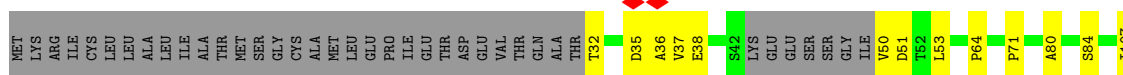

• Molecule 14: FlgH

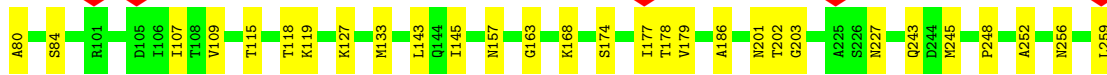
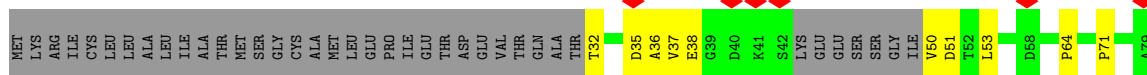

• Molecule 14: FlgH



• Molecule 14: FlgH

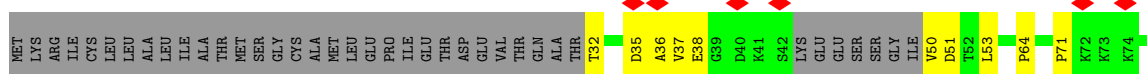

• Molecule 14: FlgH

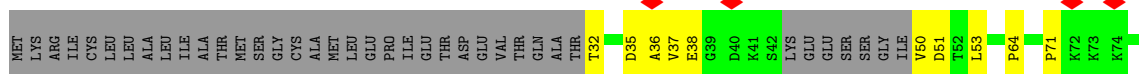

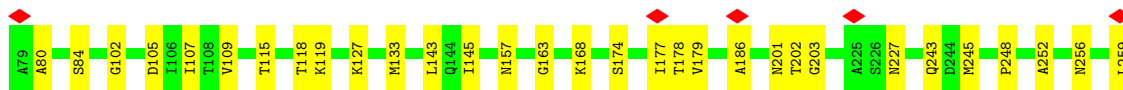

• Molecule 14: FlgH

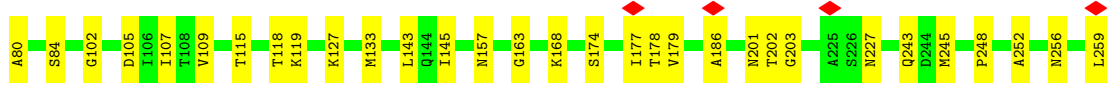
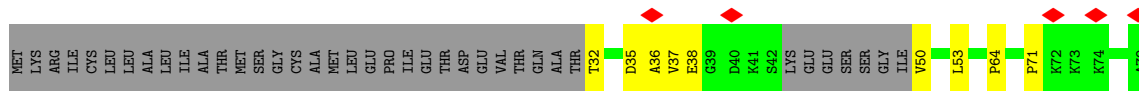

• Molecule 14: FlgH

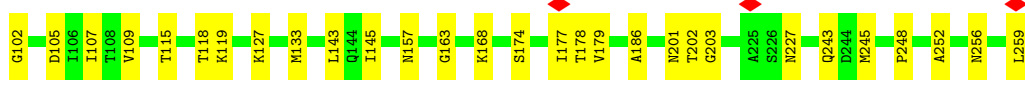
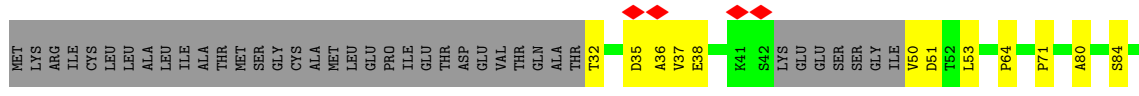

• Molecule 14: FlgH

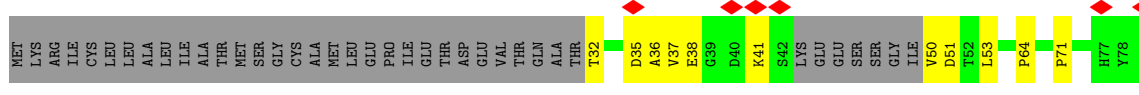

• Molecule 14: FlgH

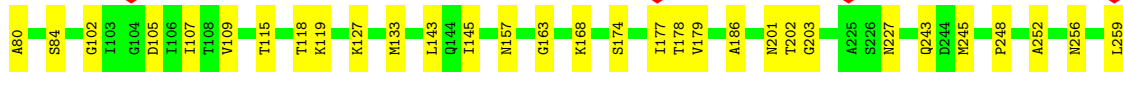
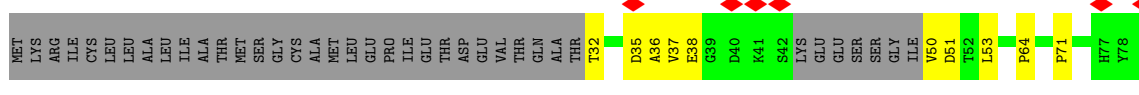

• Molecule 14: FlgH

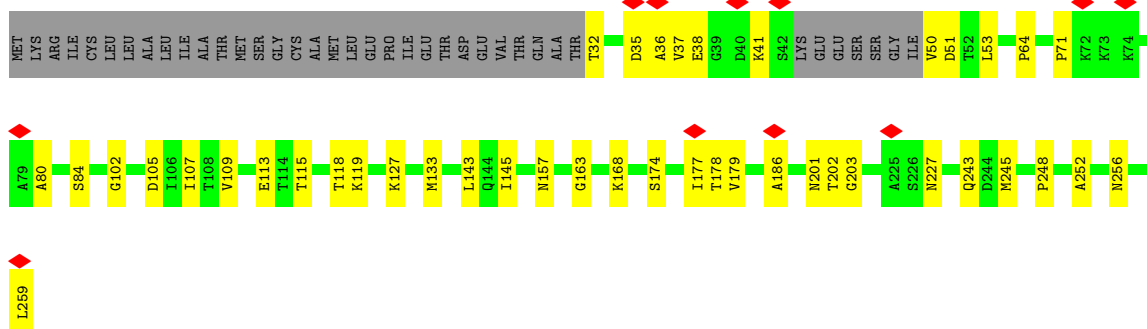

• Molecule 14: FlgH

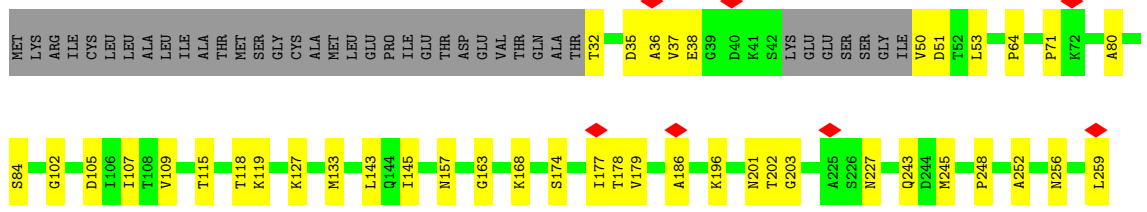

• Molecule 14: FlgH

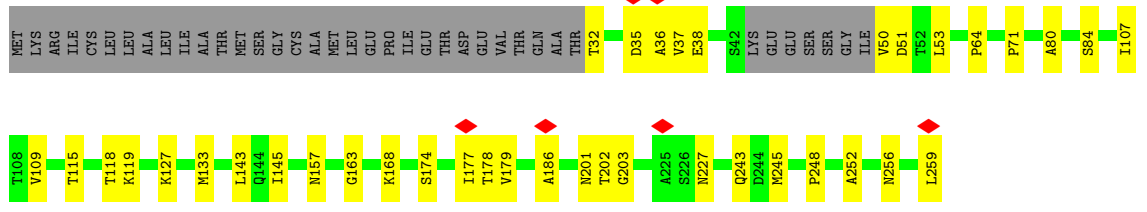

• Molecule 14: FlgH

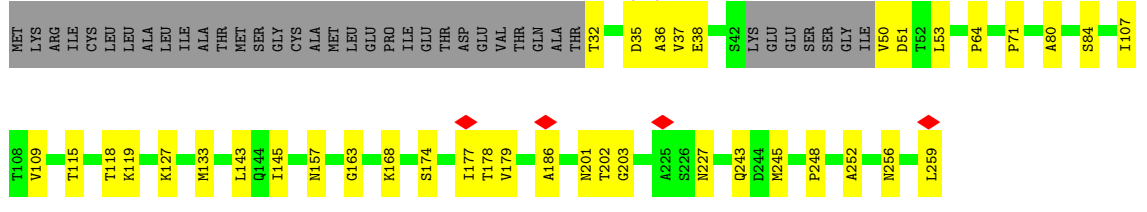

• Molecule 14: FlgH



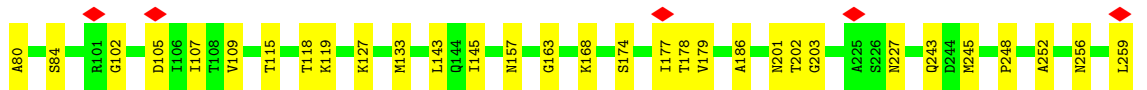
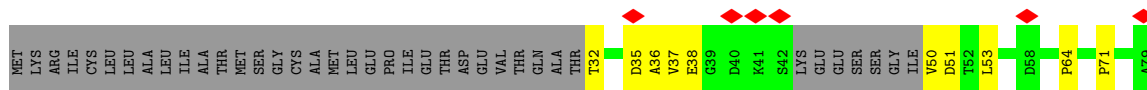

• Molecule 14: FlgH

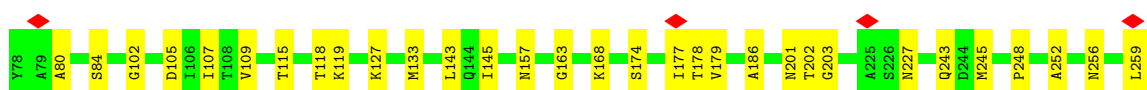
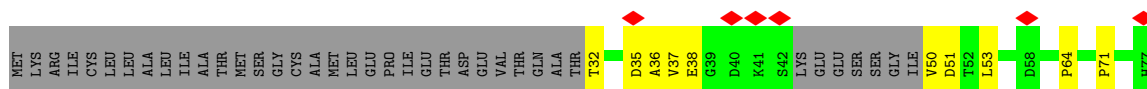

• Molecule 14: FlgH

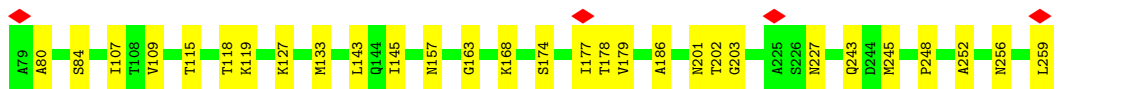
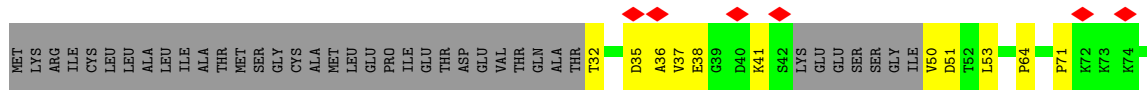

• Molecule 15: Flagellar assembly lipoprotein FlgP

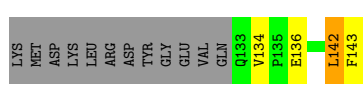
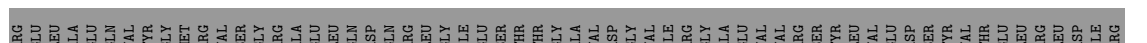
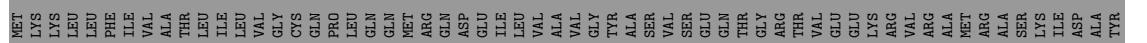

• Molecule 15: Flagellar assembly lipoprotein FlgP

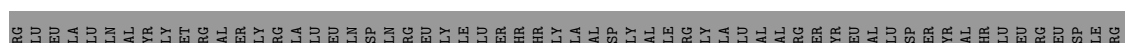
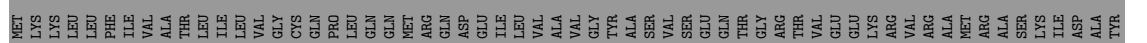

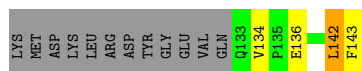

● Molecule 15: Flagellar assembly lipoprotein FlgP



MET	LYS	ASP	LYS	LEU	LEU	PHE	ARG	ASP	TYR	VAL	THR	MET	LEU	VAL	GLN	GLY	VAL	LEU	PRO	LEU	LEU	GLN	GLN	MET	ARG	LEU	ARG	GLY	GLN	ASP	GLY	GLU	ILE	SER	THR	THR	VAL	VAL	ALA	VAL	GLY	TYR	ALA	SER	VAL	SER	VAL	SER	GLY	GLU	GLN	THR	THR	GLY	VAL	ARG	THR	VAL	GLU	LYS	LYS	VAL	VAL	ASP	ASP	VAL	ARG	ALA	TYR	VAL	MET	ARG	THR	THR	GLU	ALA	ALA	LEU	LEU	SER	LEU	ILE	ASP	ASP	ALA	TYR	ARG
-----	-----	-----	-----	-----	-----	-----	-----	-----	-----	-----	-----	-----	-----	-----	-----	-----	-----	-----	-----	-----	-----	-----	-----	-----	-----	-----	-----	-----	-----	-----	-----	-----	-----	-----	-----	-----	-----	-----	-----	-----	-----	-----	-----	-----	-----	-----	-----	-----	-----	-----	-----	-----	-----	-----	-----	-----	-----	-----	-----	-----	-----	-----	-----	-----	-----	-----	-----	-----	-----	-----	-----	-----	-----	-----	-----	-----	-----	-----	-----	-----	-----	-----	-----	-----	-----	-----	-----

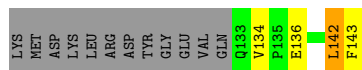

● Molecule 15: Flagellar assembly lipoprotein FlgP



MET	LYS	ASP	LYS	LEU	LEU	PHE	ARG	ASP	TYR	VAL	THR	MET	LEU	VAL	GLN	GLY	VAL	LEU	PRO	LEU	LEU	GLN	GLN	MET	ARG	LEU	ARG	GLY	GLN	ASP	GLY	GLU	ILE	SER	THR	THR	VAL	VAL	ALA	VAL	GLY	TYR	ALA	SER	VAL	SER	VAL	SER	GLY	GLU	GLN	THR	THR	GLY	VAL	ARG	THR	VAL	GLU	LYS	LYS	VAL	VAL	ASP	ASP	VAL	ARG	ALA	TYR	VAL	MET	ARG	THR	THR	GLU	ALA	ALA	LEU	LEU	SER	LEU	ILE	ASP	ASP	ALA	TYR	ARG
-----	-----	-----	-----	-----	-----	-----	-----	-----	-----	-----	-----	-----	-----	-----	-----	-----	-----	-----	-----	-----	-----	-----	-----	-----	-----	-----	-----	-----	-----	-----	-----	-----	-----	-----	-----	-----	-----	-----	-----	-----	-----	-----	-----	-----	-----	-----	-----	-----	-----	-----	-----	-----	-----	-----	-----	-----	-----	-----	-----	-----	-----	-----	-----	-----	-----	-----	-----	-----	-----	-----	-----	-----	-----	-----	-----	-----	-----	-----	-----	-----	-----	-----	-----	-----	-----	-----	-----

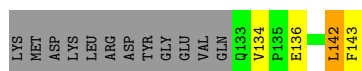

● Molecule 15: Flagellar assembly lipoprotein FlgP



MET	LYS	ASP	LYS	LEU	LEU	PHE	ARG	ASP	TYR	VAL	THR	MET	LEU	VAL	GLN	GLY	VAL	LEU	PRO	LEU	LEU	GLN	GLN	MET	ARG	LEU	ARG	GLY	GLN	ASP	GLY	GLU	ILE	SER	THR	THR	VAL	VAL	ALA	VAL	GLY	TYR	ALA	SER	VAL	SER	VAL	SER	GLY	GLU	GLN	THR	THR	GLY	VAL	ARG	THR	VAL	GLU	LYS	LYS	VAL	VAL	ASP	ASP	VAL	ARG	ALA	TYR	VAL	MET	ARG	THR	THR	GLU	ALA	ALA	LEU	LEU	SER	LEU	ILE	ASP	ASP	ALA	TYR	ARG
-----	-----	-----	-----	-----	-----	-----	-----	-----	-----	-----	-----	-----	-----	-----	-----	-----	-----	-----	-----	-----	-----	-----	-----	-----	-----	-----	-----	-----	-----	-----	-----	-----	-----	-----	-----	-----	-----	-----	-----	-----	-----	-----	-----	-----	-----	-----	-----	-----	-----	-----	-----	-----	-----	-----	-----	-----	-----	-----	-----	-----	-----	-----	-----	-----	-----	-----	-----	-----	-----	-----	-----	-----	-----	-----	-----	-----	-----	-----	-----	-----	-----	-----	-----	-----	-----	-----	-----

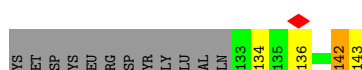

● Molecule 15: Flagellar assembly lipoprotein FlgP



MET	LYS	ASP	LYS	LEU	LEU	PHE	ARG	ASP	TYR	VAL	THR	MET	LEU	VAL	GLN	GLY	VAL	LEU	PRO	LEU	LEU	GLN	GLN	MET	ARG	LEU	ARG	GLY	GLN	ASP	GLY	GLU	ILE	SER	THR	THR	VAL	VAL	ALA	VAL	GLY	TYR	ALA	SER	VAL	SER	VAL	SER	GLY	GLU	GLN	THR	THR	GLY	VAL	ARG	THR	VAL	GLU	LYS	LYS	VAL	VAL	ASP	ASP	VAL	ARG	ALA	TYR	VAL	MET	ARG	THR	THR	GLU	ALA	ALA	LEU	LEU	SER	LEU	ILE	ASP	ASP	ALA	TYR	ARG
-----	-----	-----	-----	-----	-----	-----	-----	-----	-----	-----	-----	-----	-----	-----	-----	-----	-----	-----	-----	-----	-----	-----	-----	-----	-----	-----	-----	-----	-----	-----	-----	-----	-----	-----	-----	-----	-----	-----	-----	-----	-----	-----	-----	-----	-----	-----	-----	-----	-----	-----	-----	-----	-----	-----	-----	-----	-----	-----	-----	-----	-----	-----	-----	-----	-----	-----	-----	-----	-----	-----	-----	-----	-----	-----	-----	-----	-----	-----	-----	-----	-----	-----	-----	-----	-----	-----	-----

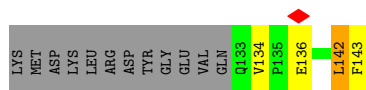

- Molecule 15: Flagellar assembly lipoprotein FlgP

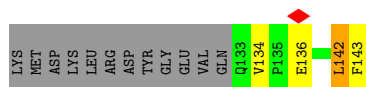
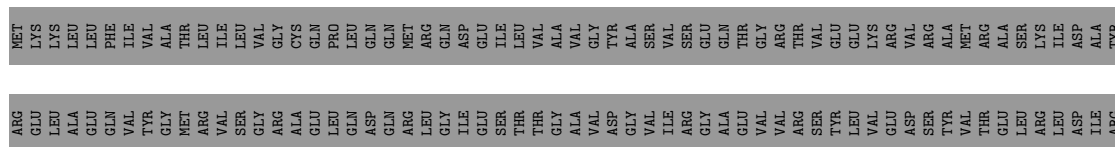

- Molecule 15: Flagellar assembly lipoprotein FlgP

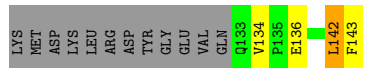
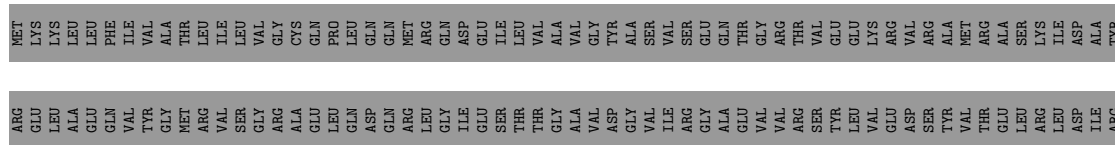

- Molecule 15: Flagellar assembly lipoprotein FlgP

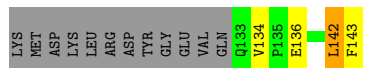
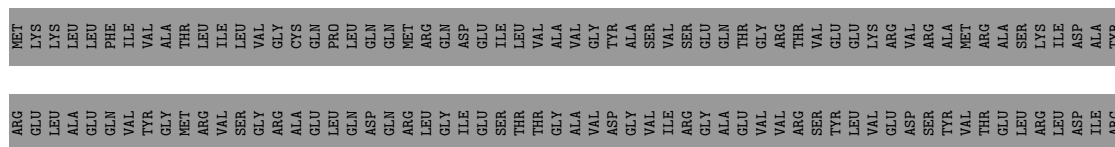

- Molecule 15: Flagellar assembly lipoprotein FlgP

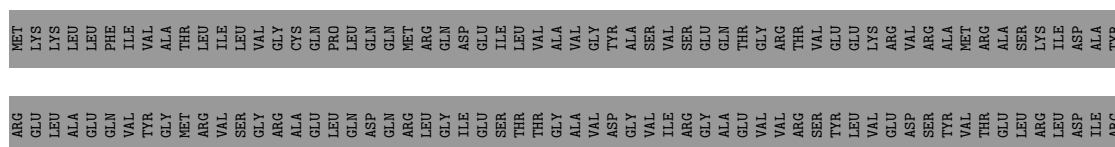

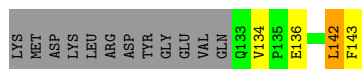

● Molecule 15: Flagellar assembly lipoprotein FlgP

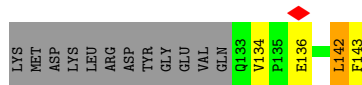
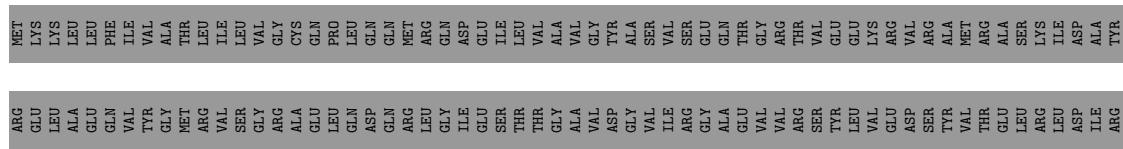

● Molecule 15: Flagellar assembly lipoprotein FlgP

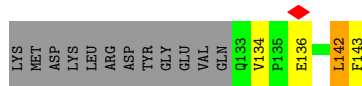
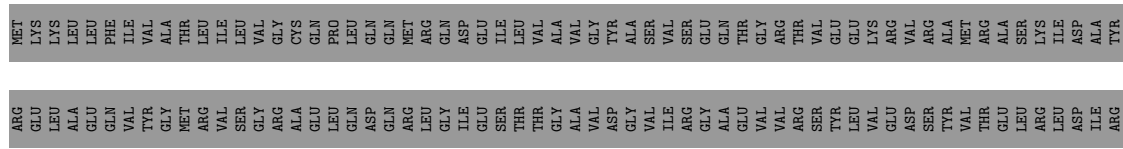

● Molecule 15: Flagellar assembly lipoprotein FlgP

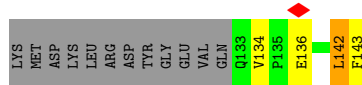
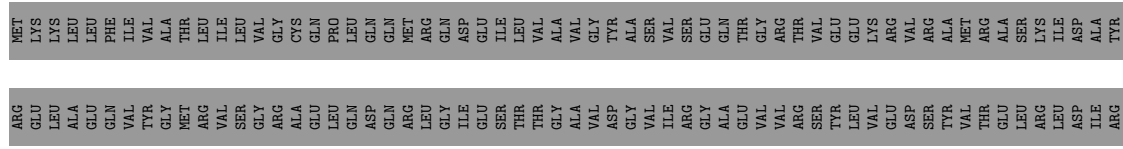

● Molecule 15: Flagellar assembly lipoprotein FlgP

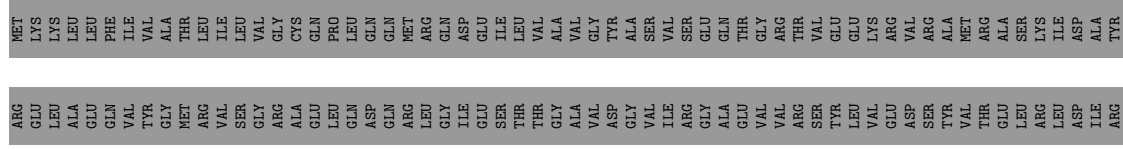

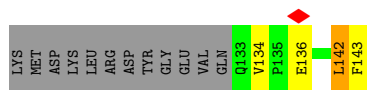

● Molecule 15: Flagellar assembly lipoprotein FlgP

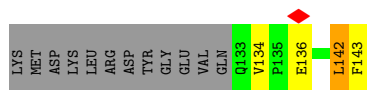
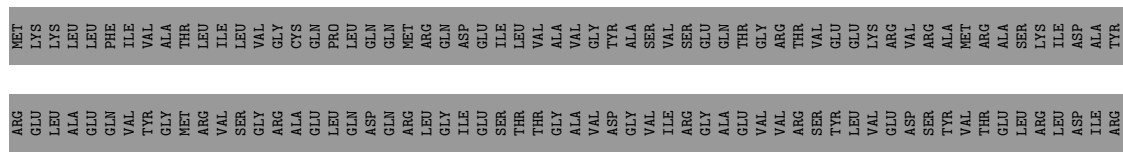

● Molecule 15: Flagellar assembly lipoprotein FlgP

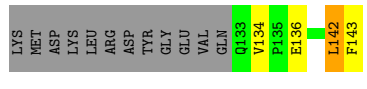
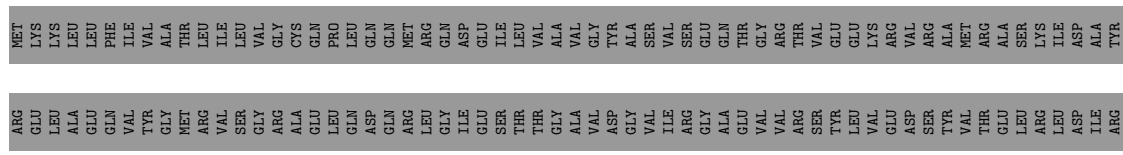

● Molecule 15: Flagellar assembly lipoprotein FlgP

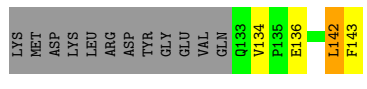
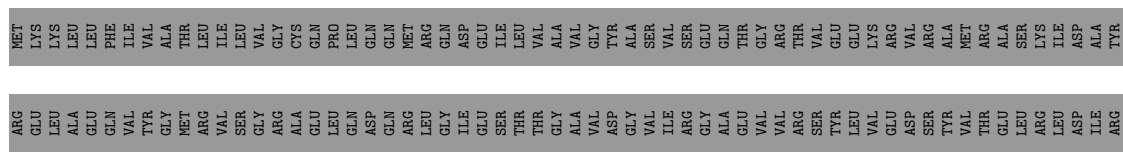

● Molecule 15: Flagellar assembly lipoprotein FlgP

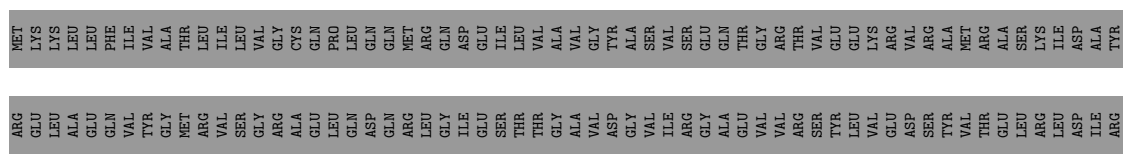

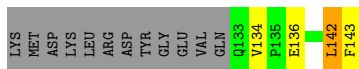

• Molecule 15: Flagellar assembly lipoprotein FlgP

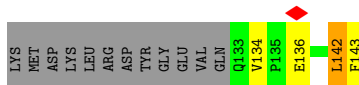
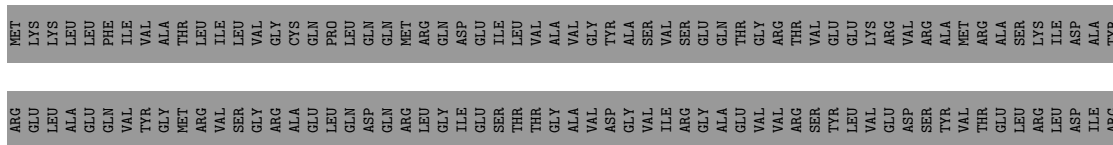

• Molecule 15: Flagellar assembly lipoprotein FlgP

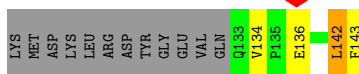
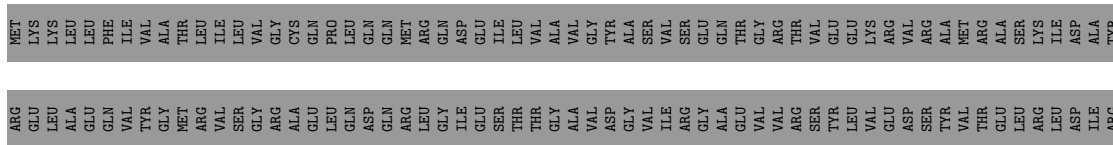

• Molecule 15: Flagellar assembly lipoprotein FlgP

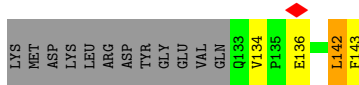
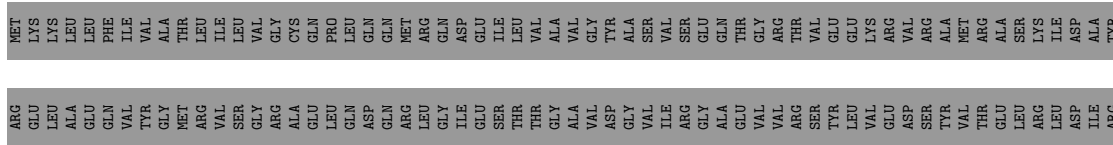

• Molecule 15: Flagellar assembly lipoprotein FlgP

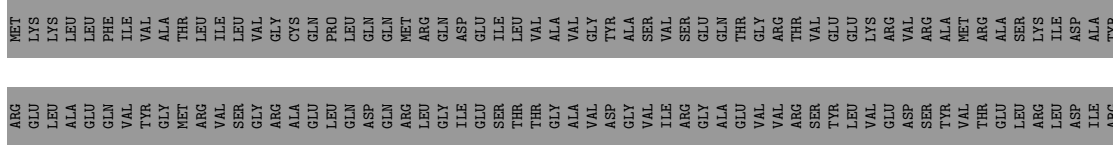

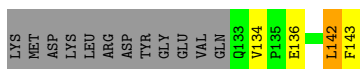

• Molecule 16: FlgH

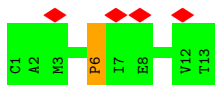

• Molecule 16: FlgH

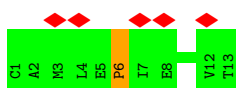
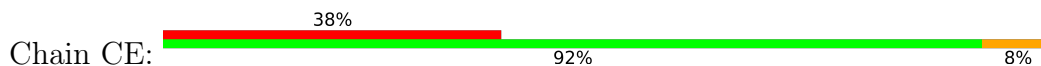

• Molecule 16: FlgH

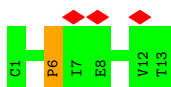

• Molecule 16: FlgH

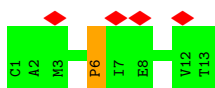

• Molecule 16: FlgH

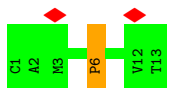

• Molecule 16: FlgH



• Molecule 16: FlgH

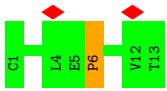

- Molecule 16: FlgH

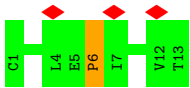
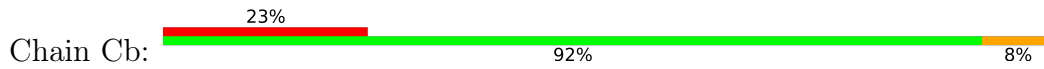

- Molecule 16: FlgH

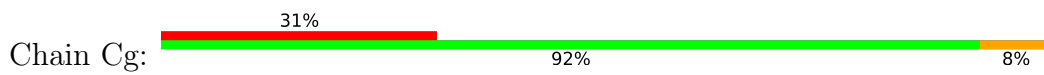

- Molecule 16: FlgH

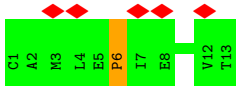

- Molecule 16: FlgH

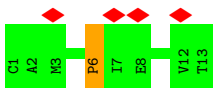

- Molecule 16: FlgH

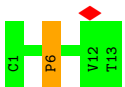
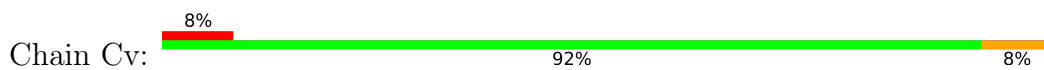

- Molecule 16: FlgH

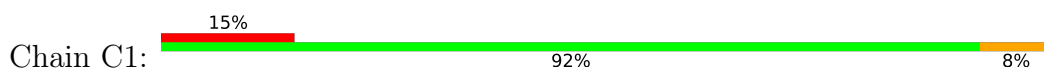

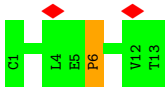

- Molecule 16: FlgH

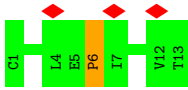
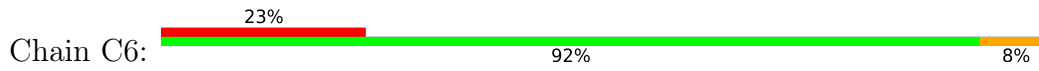

- Molecule 16: FlgH

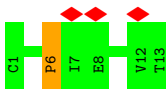

- Molecule 16: FlgH

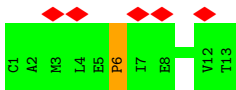
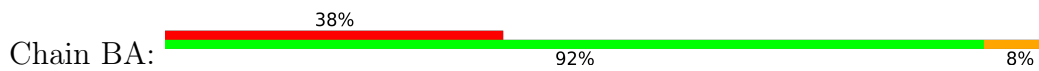

- Molecule 16: FlgH

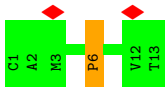

- Molecule 16: FlgH

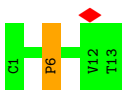

- Molecule 16: FlgH

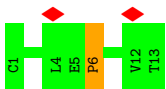
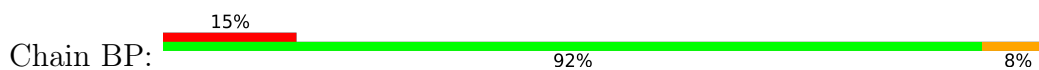

- Molecule 16: FlgH

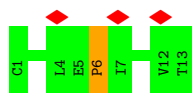
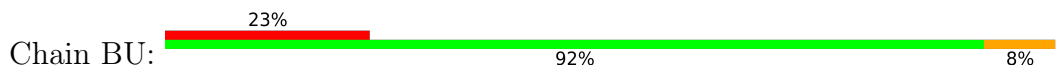

• Molecule 16: FlgH

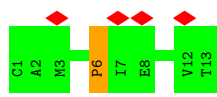
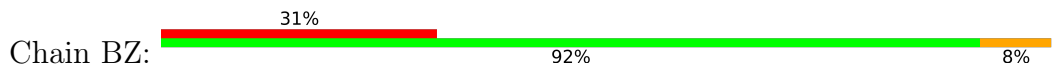

• Molecule 16: FlgH

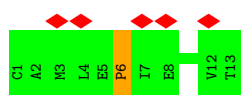
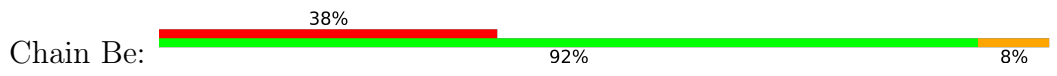

• Molecule 16: FlgH

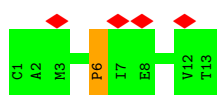
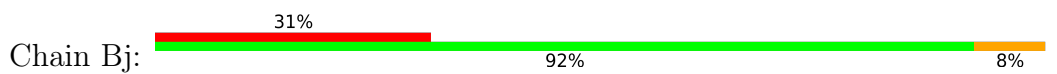

• Molecule 16: FlgH

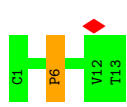
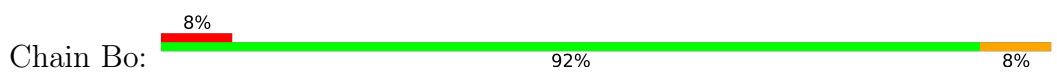

• Molecule 16: FlgH

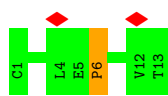
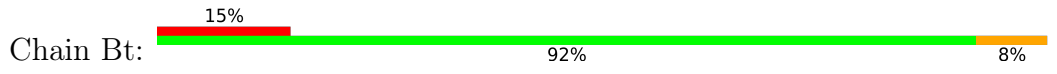

• Molecule 16: FlgH

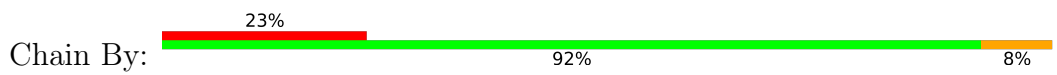

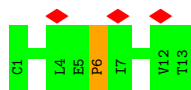

• Molecule 16: FlgH

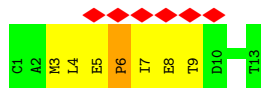

• Molecule 17: FlgI

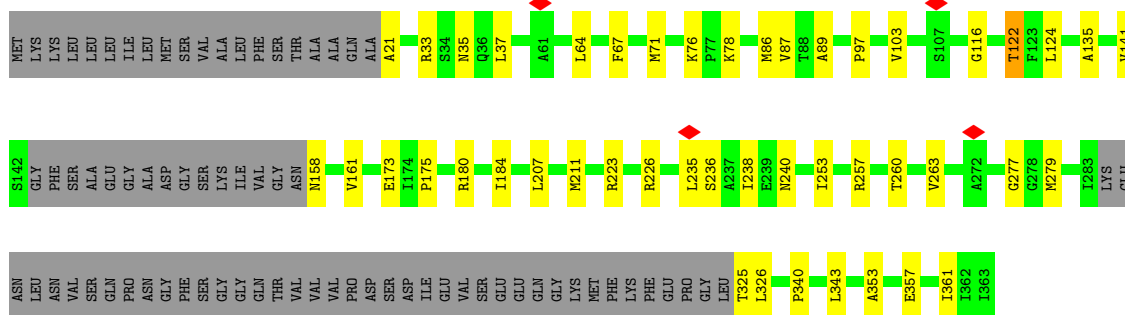

• Molecule 17: FlgI

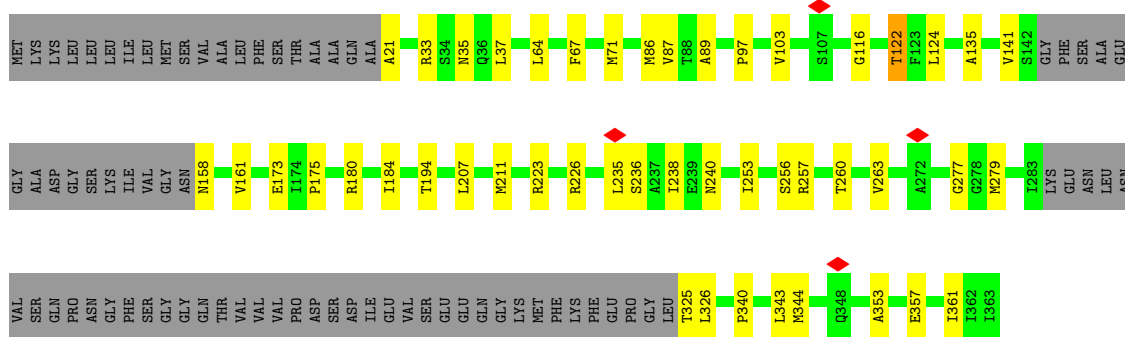

• Molecule 17: FlgI

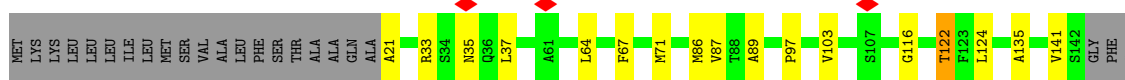

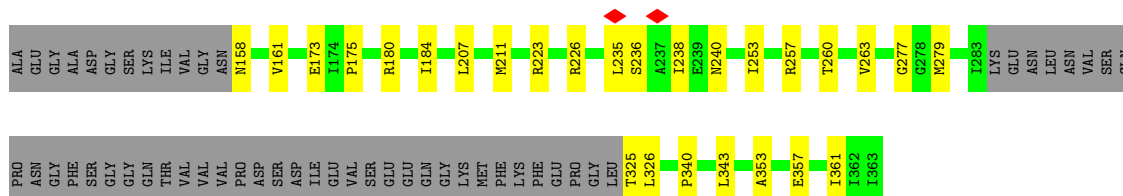

• Molecule 17: FlgI

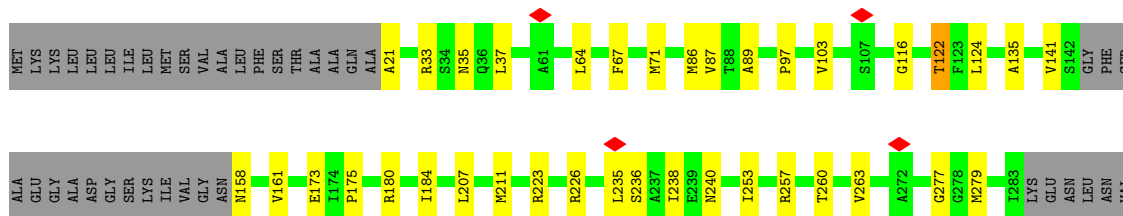

• Molecule 17: FlgI

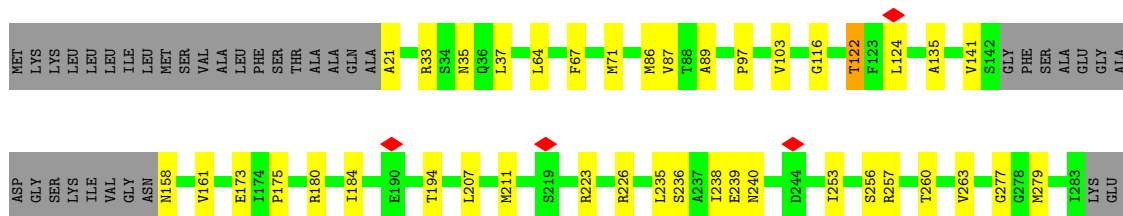

• Molecule 17: FlgI

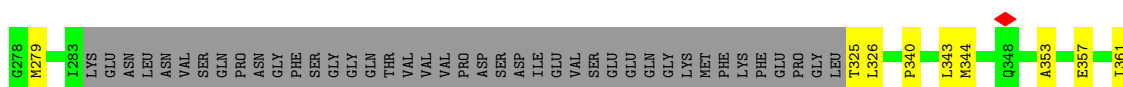
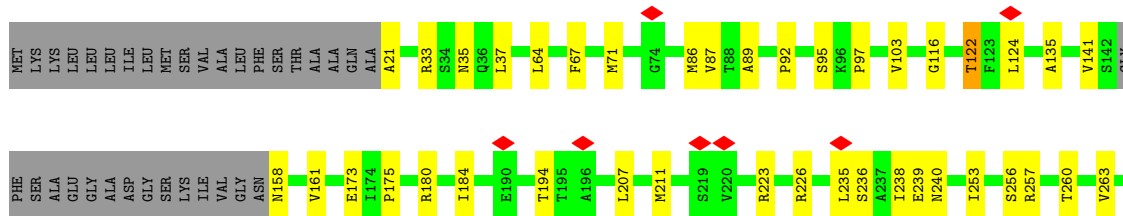

I362
I363

• Molecule 17: FlgI

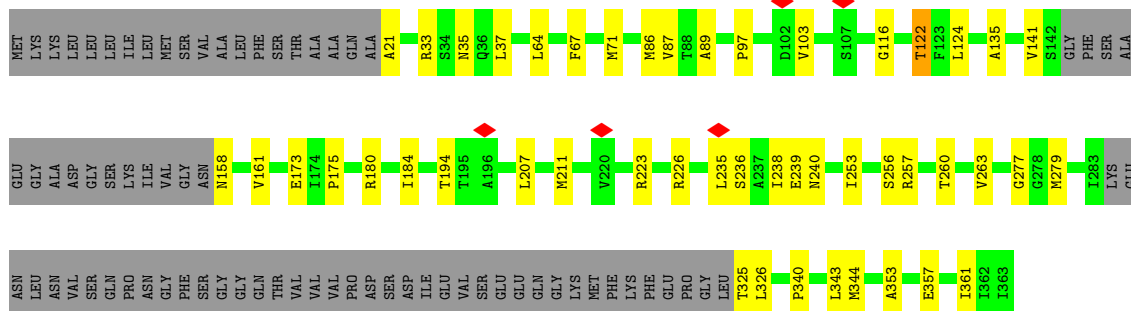

• Molecule 17: FlgI

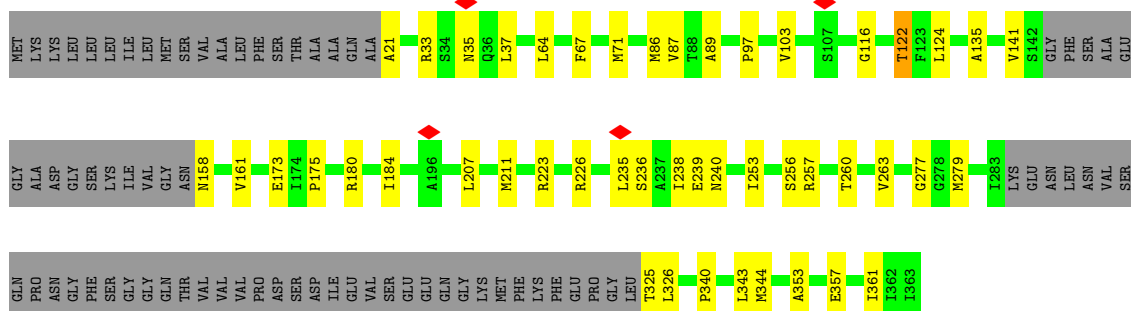

• Molecule 17: FlgI

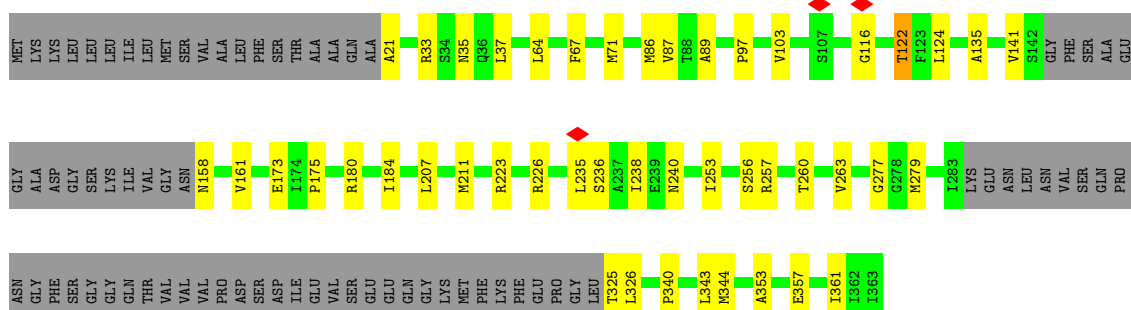

• Molecule 17: FlgI



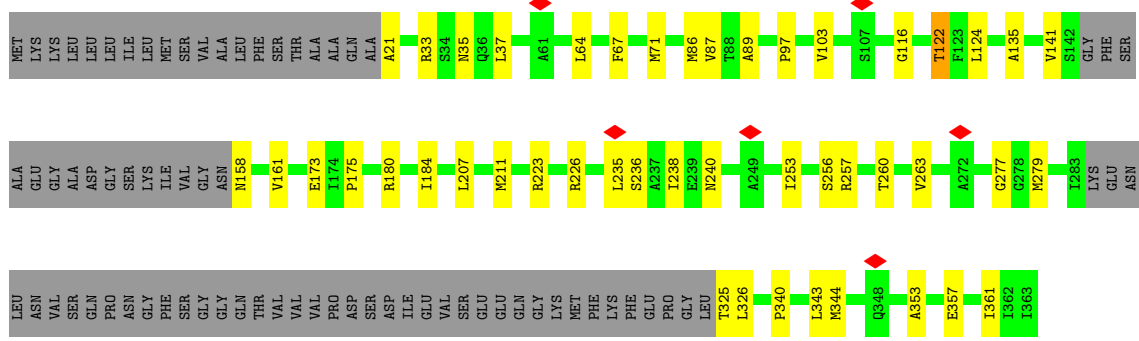

• Molecule 17: FlgI

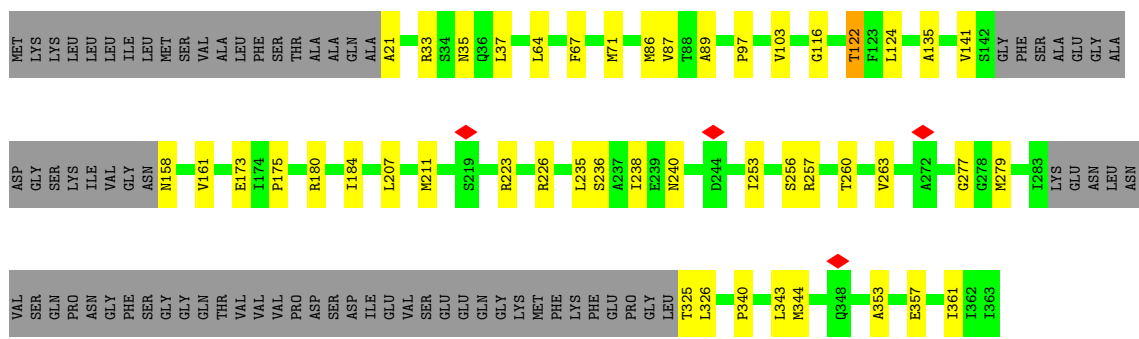

• Molecule 17: FlgI

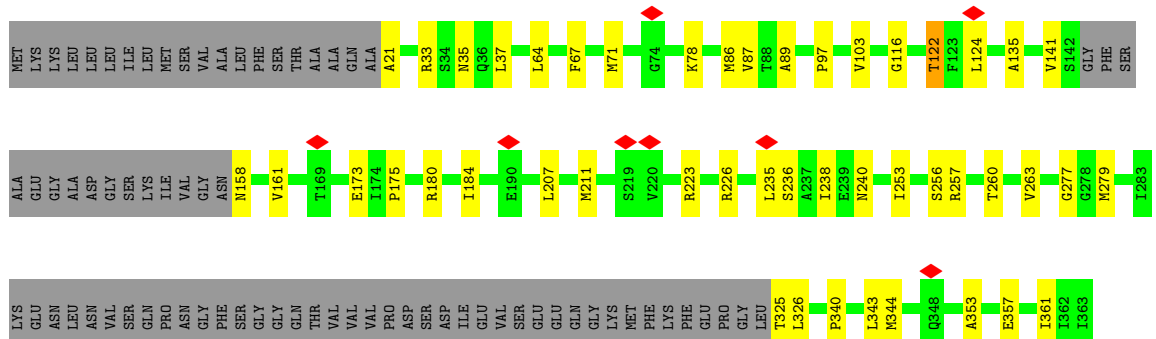

• Molecule 17: FlgI

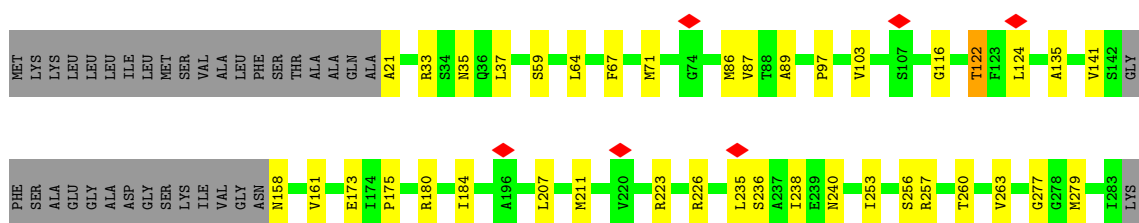

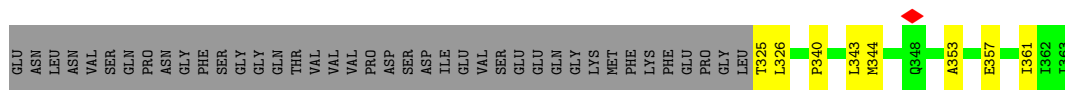

• Molecule 17: FlgI

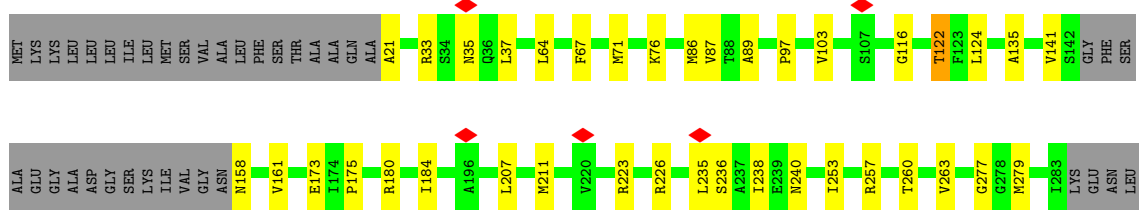

• Molecule 17: FlgI

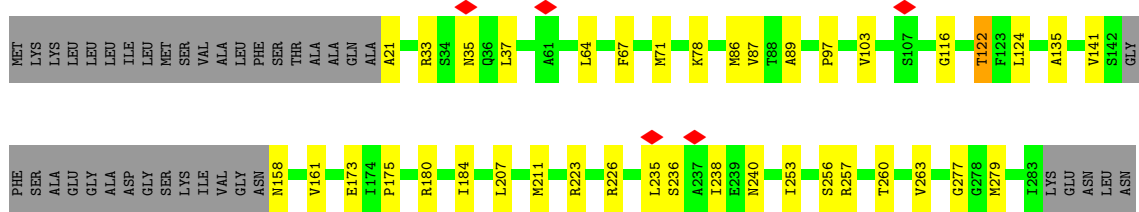

• Molecule 17: FlgI

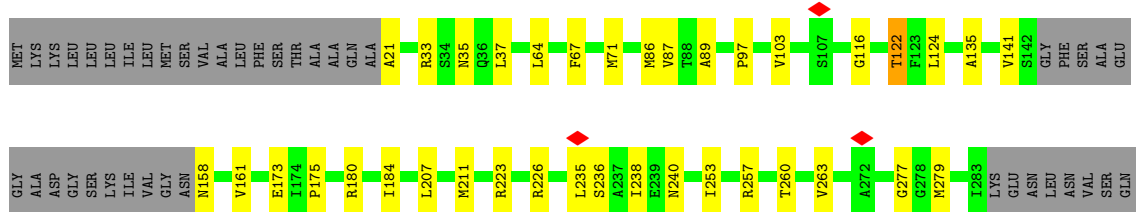

• Molecule 17: FlgI



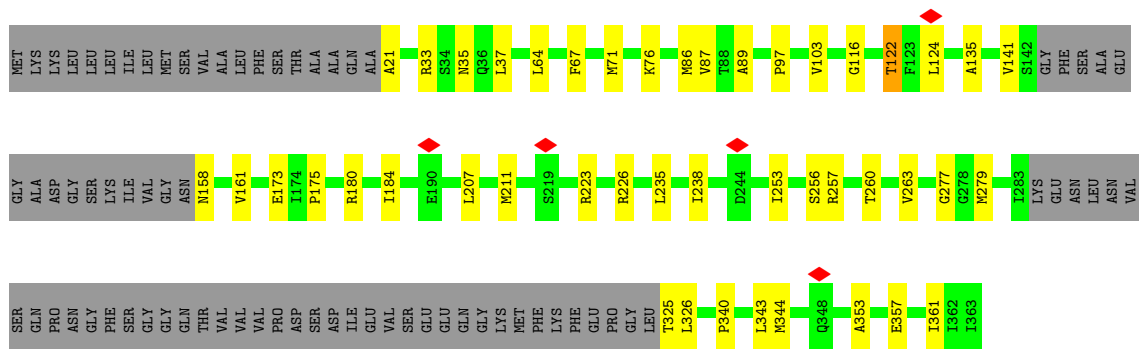

• Molecule 17: FlgI

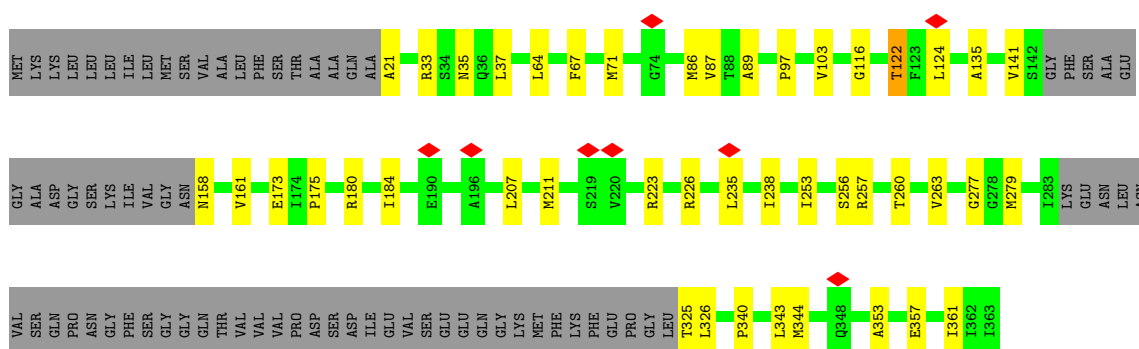

• Molecule 17: FlgI

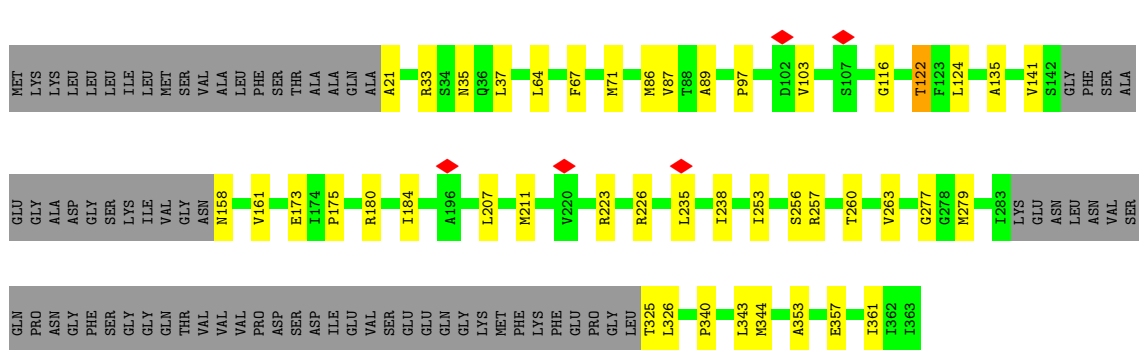

• Molecule 17: FlgI

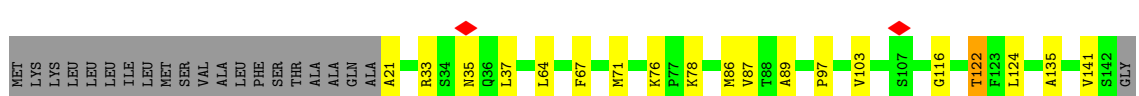

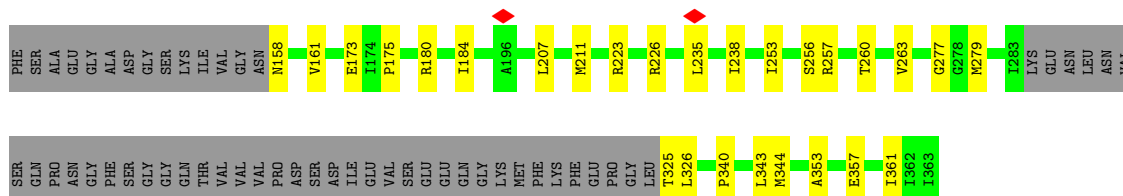

• Molecule 17: FlgI

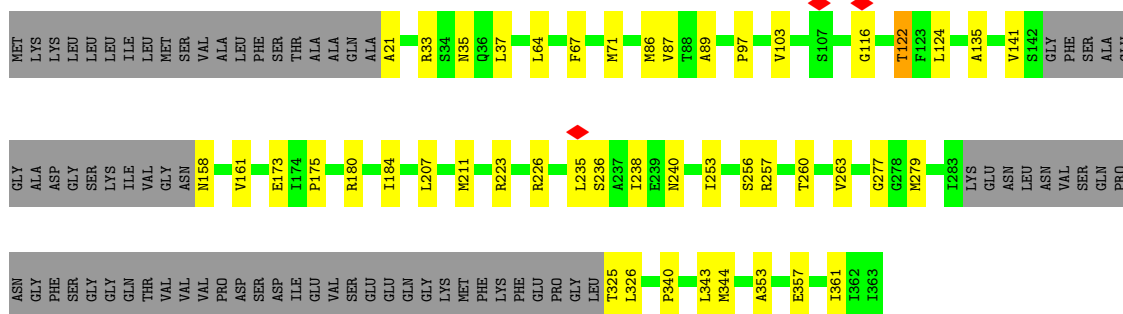

• Molecule 17: FlgI

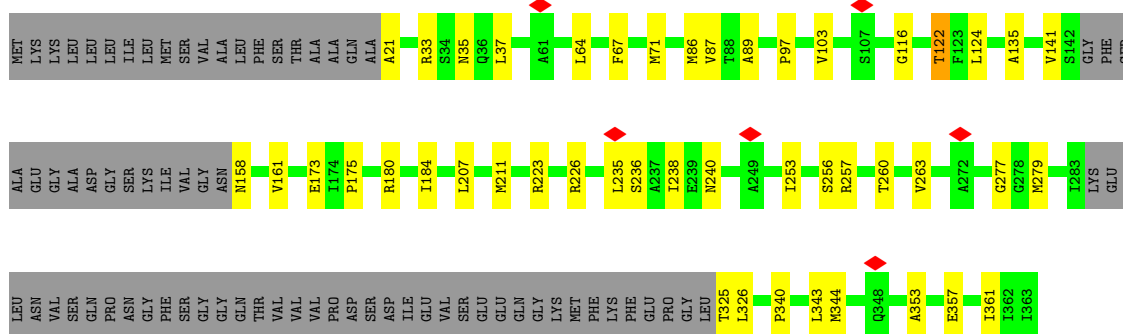

• Molecule 17: FlgI

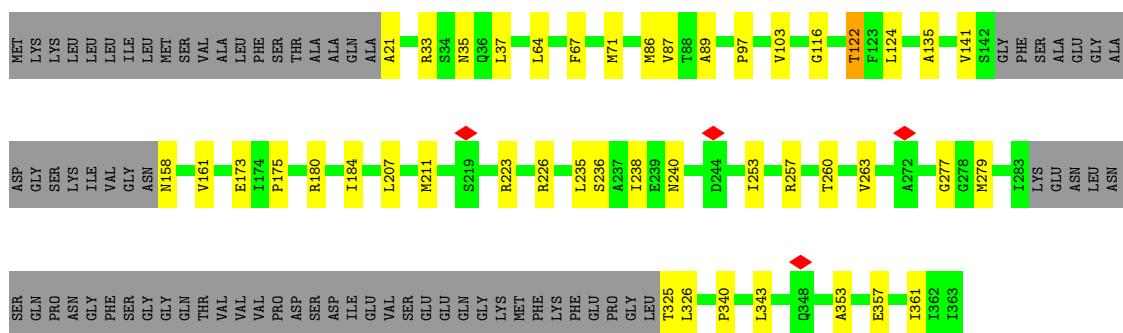

• Molecule 17: FlgI

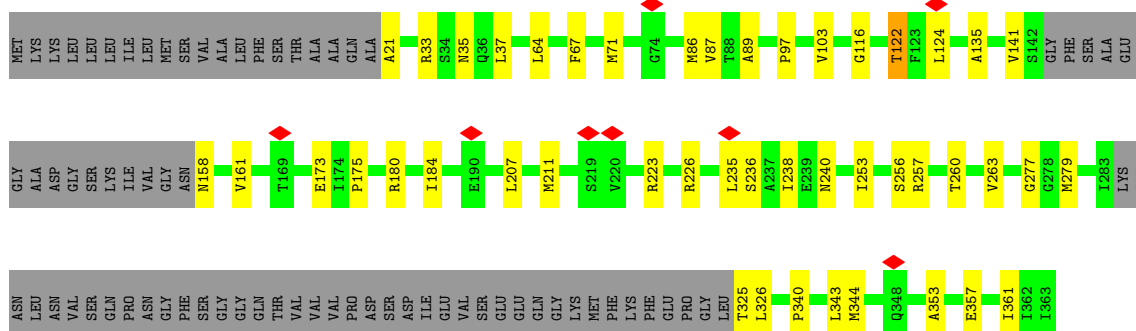

• Molecule 17: FlgI

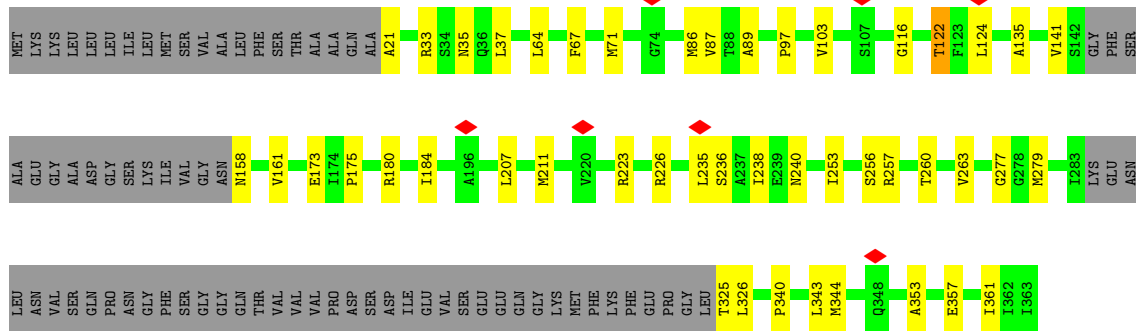

• Molecule 17: FlgI

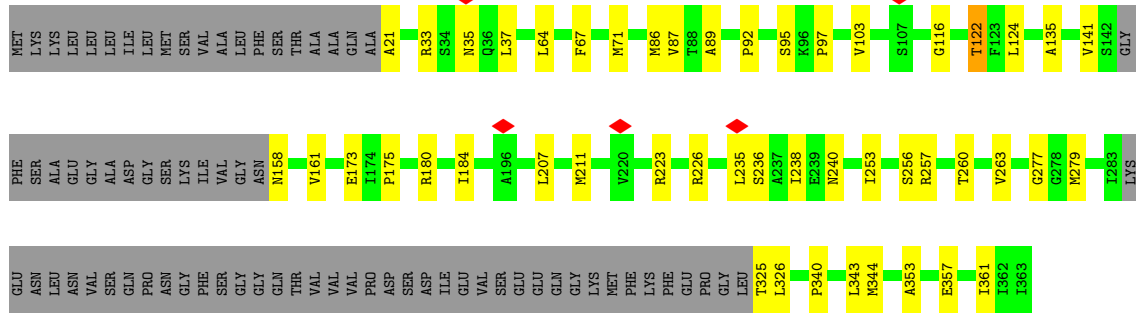

• Molecule 18: Component of sodium-driven polar flagellar motor

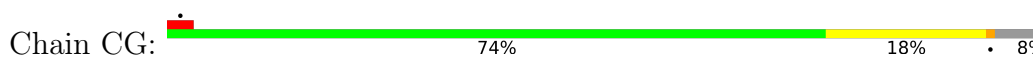

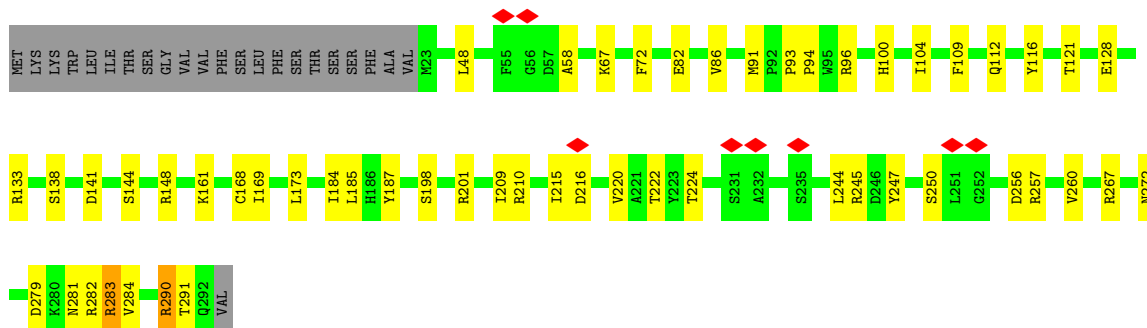

• Molecule 18: Component of sodium-driven polar flagellar motor

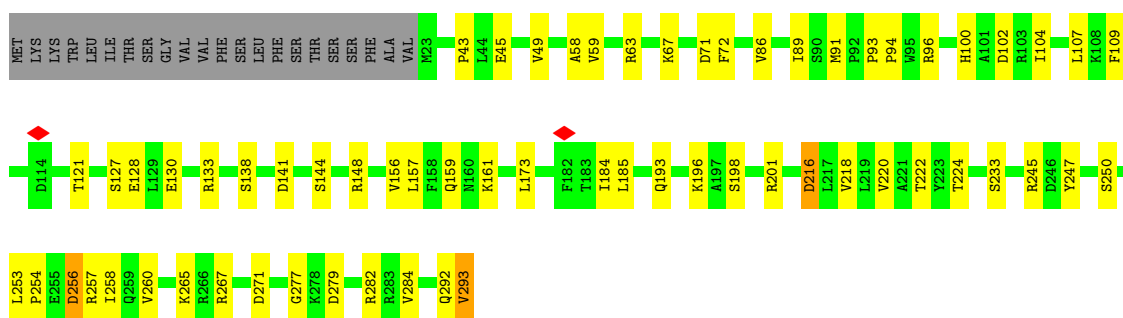

• Molecule 18: Component of sodium-driven polar flagellar motor

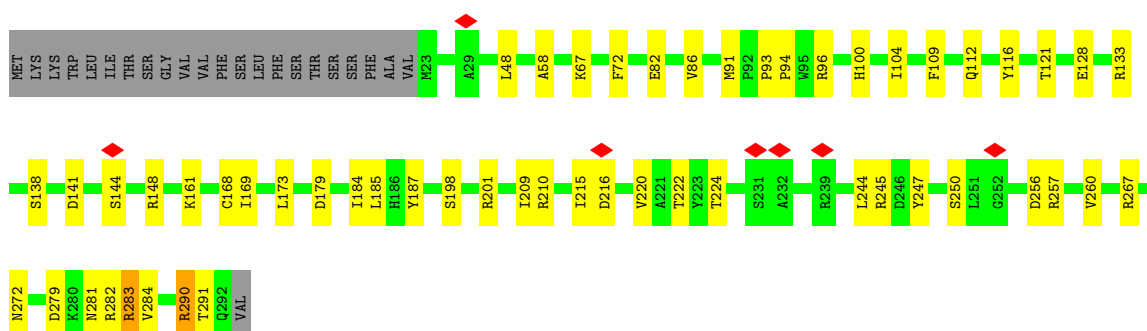
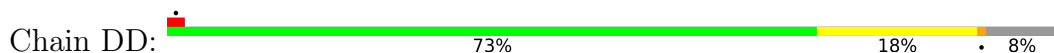

• Molecule 18: Component of sodium-driven polar flagellar motor

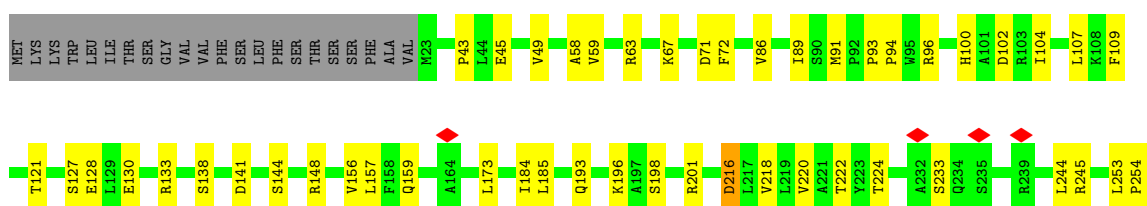



• Molecule 18: Component of sodium-driven polar flagellar motor

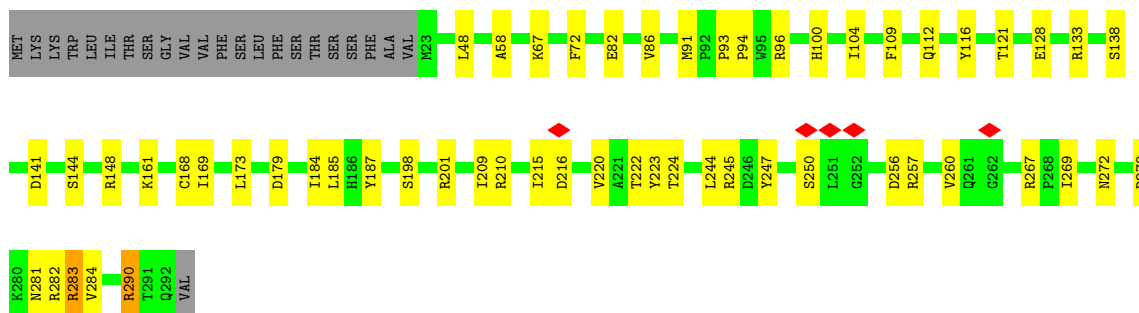
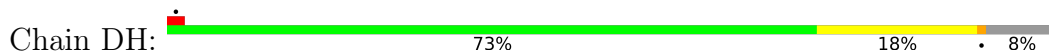

• Molecule 18: Component of sodium-driven polar flagellar motor

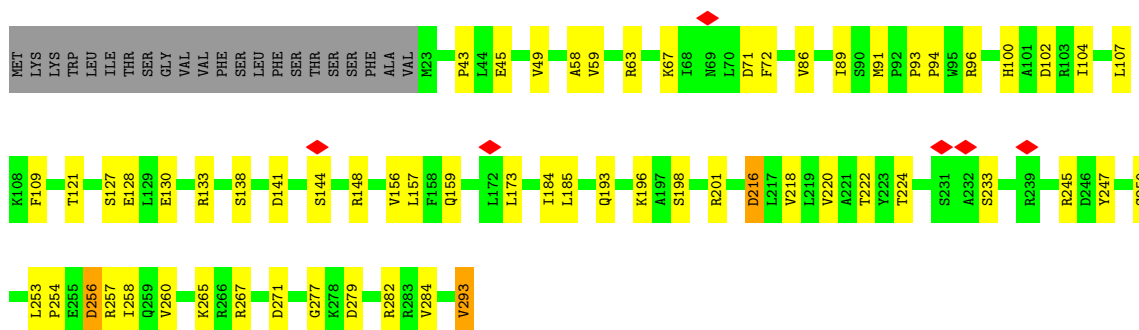

• Molecule 18: Component of sodium-driven polar flagellar motor

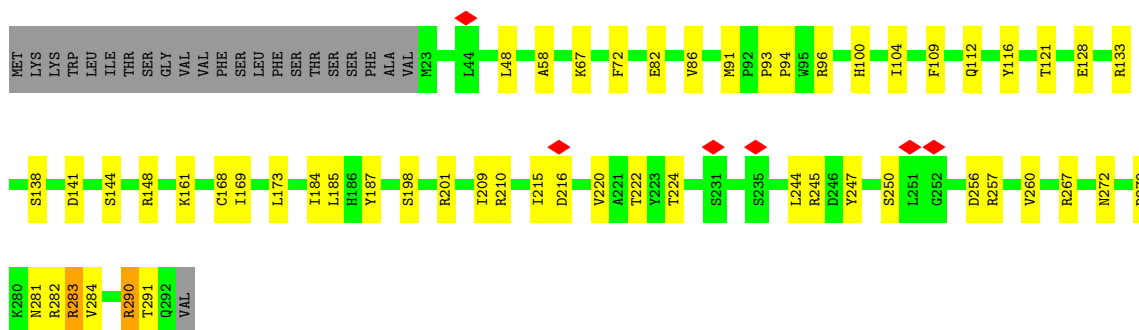
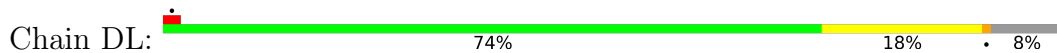

• Molecule 18: Component of sodium-driven polar flagellar motor



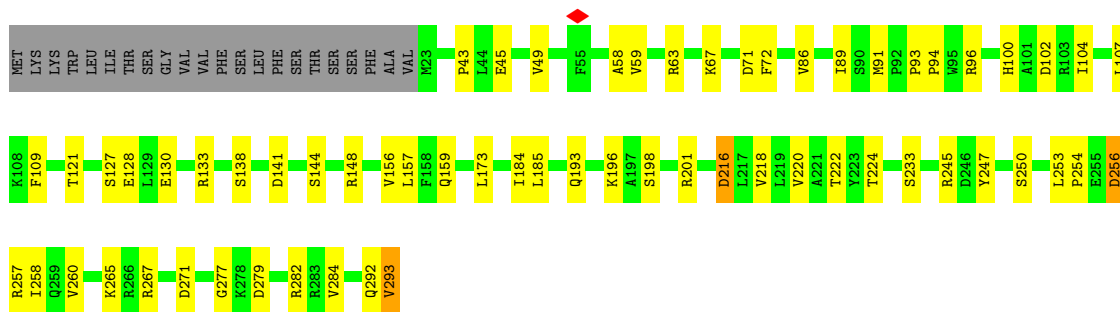

• Molecule 18: Component of sodium-driven polar flagellar motor

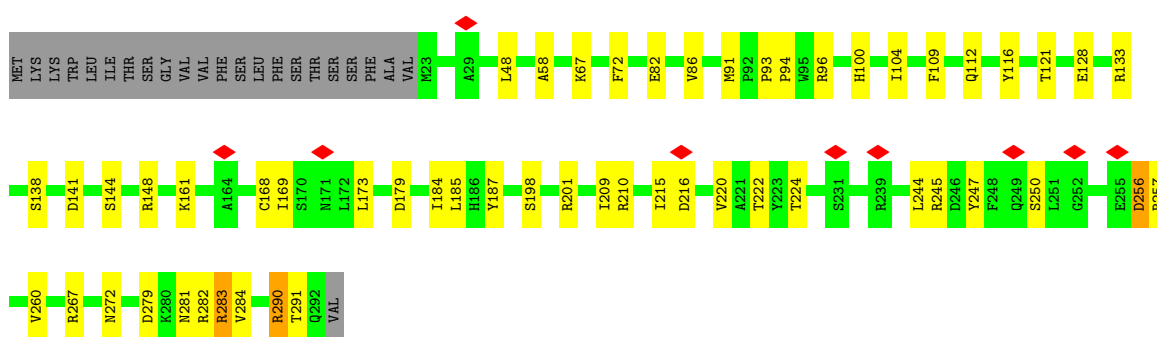
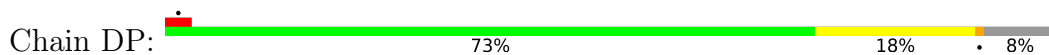

• Molecule 18: Component of sodium-driven polar flagellar motor

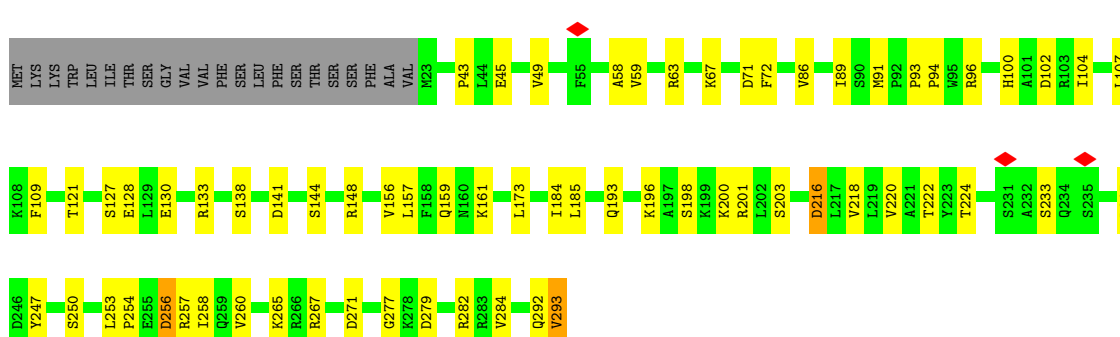

• Molecule 18: Component of sodium-driven polar flagellar motor

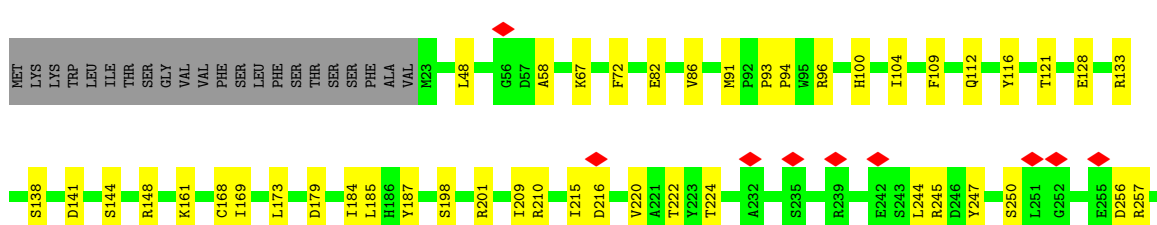



• Molecule 18: Component of sodium-driven polar flagellar motor

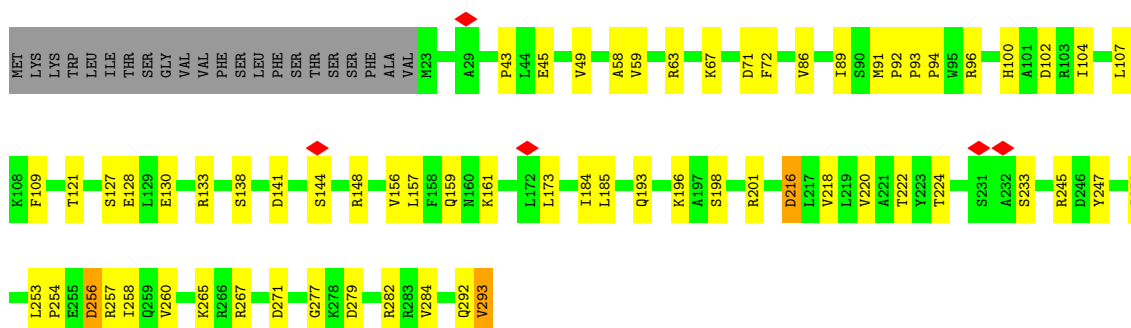

• Molecule 18: Component of sodium-driven polar flagellar motor

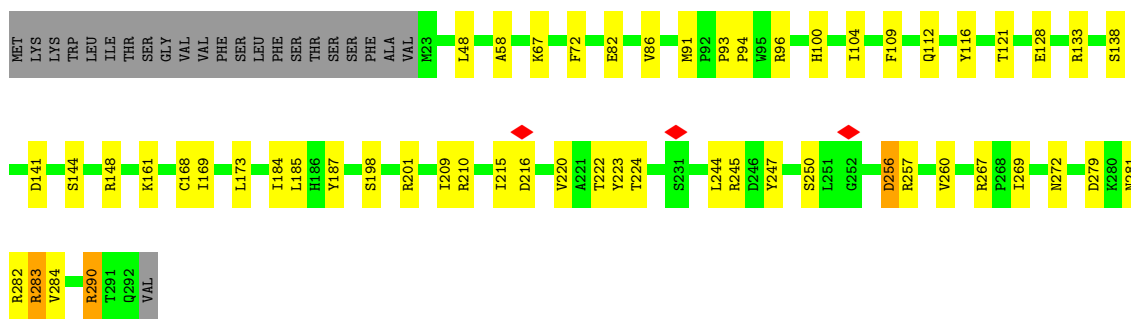
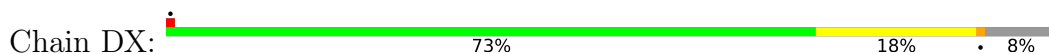

• Molecule 18: Component of sodium-driven polar flagellar motor

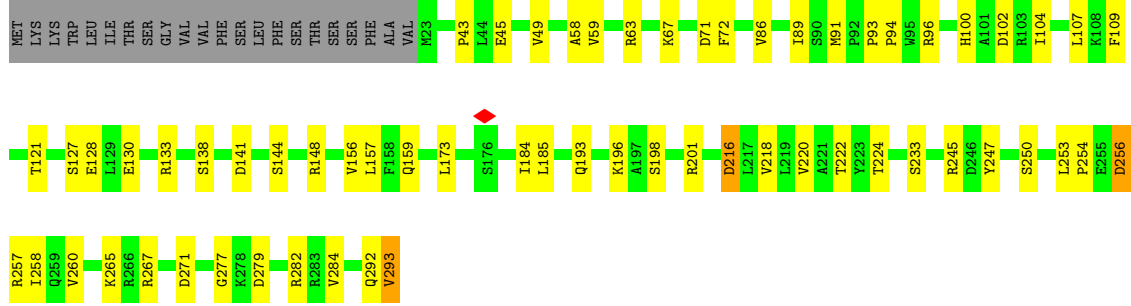

• Molecule 18: Component of sodium-driven polar flagellar motor

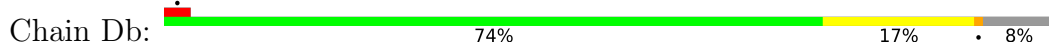

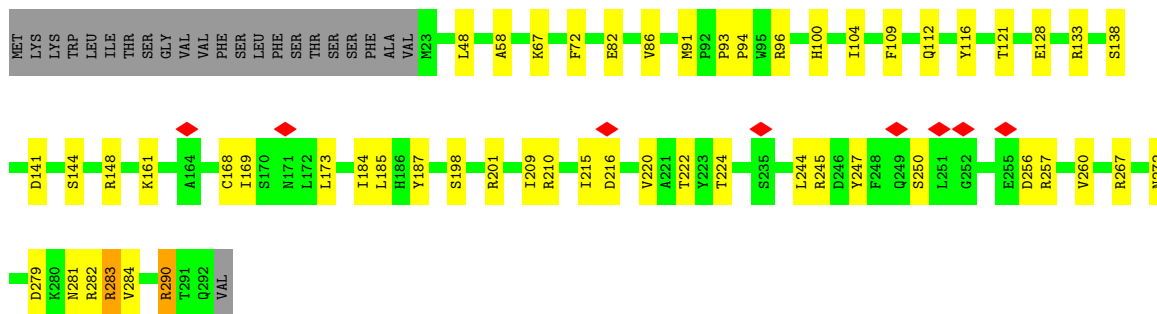

• Molecule 18: Component of sodium-driven polar flagellar motor

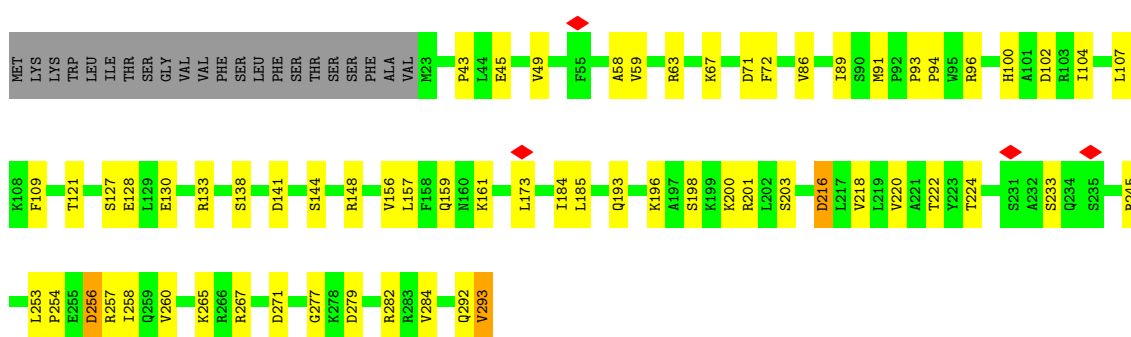
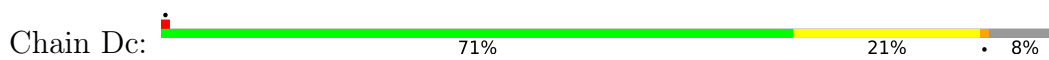

• Molecule 18: Component of sodium-driven polar flagellar motor

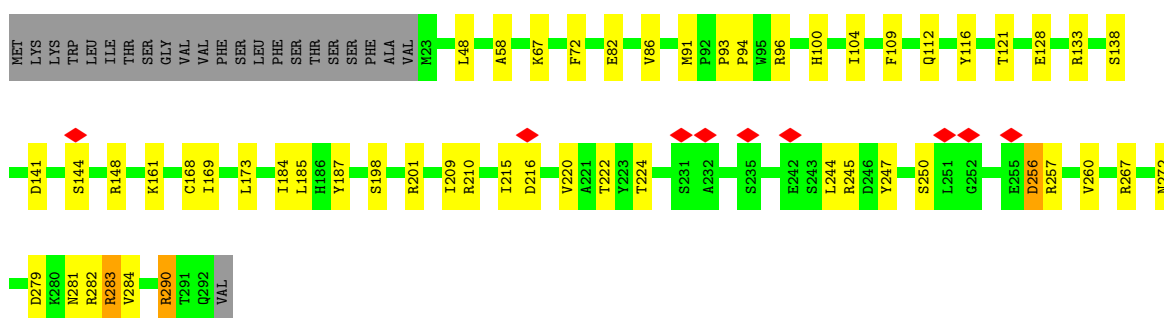
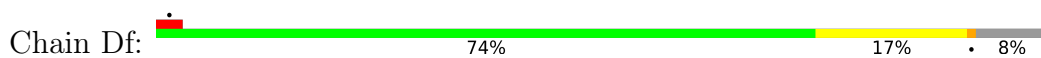

• Molecule 18: Component of sodium-driven polar flagellar motor

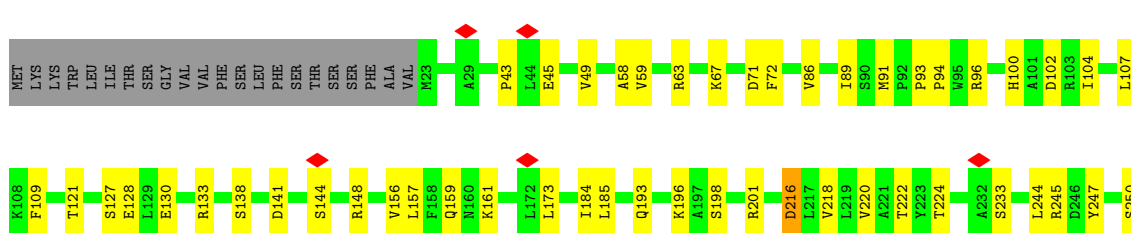



• Molecule 18: Component of sodium-driven polar flagellar motor

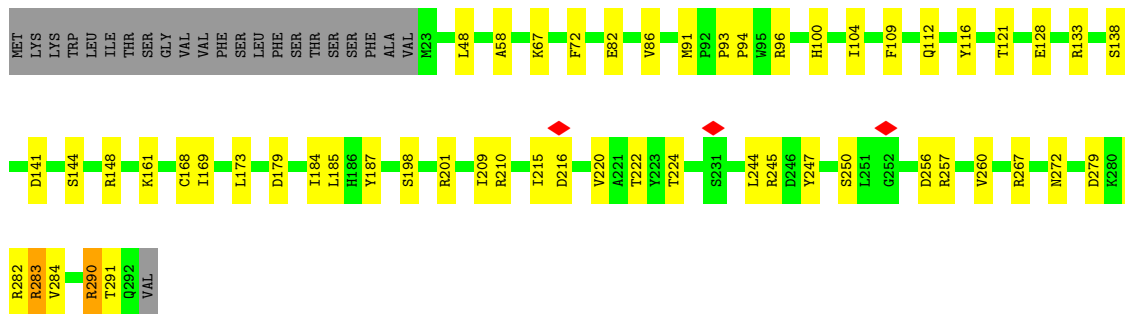
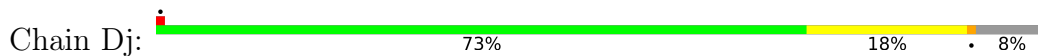

• Molecule 18: Component of sodium-driven polar flagellar motor

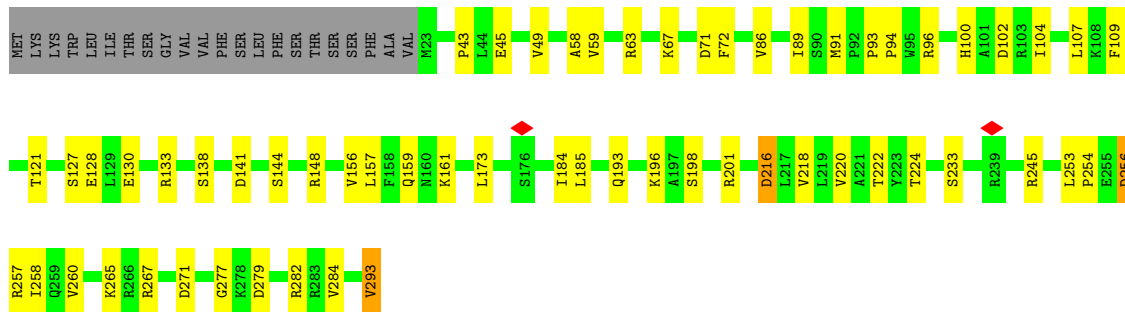
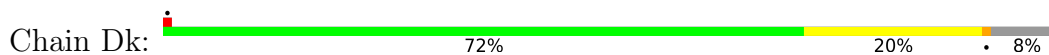

• Molecule 18: Component of sodium-driven polar flagellar motor

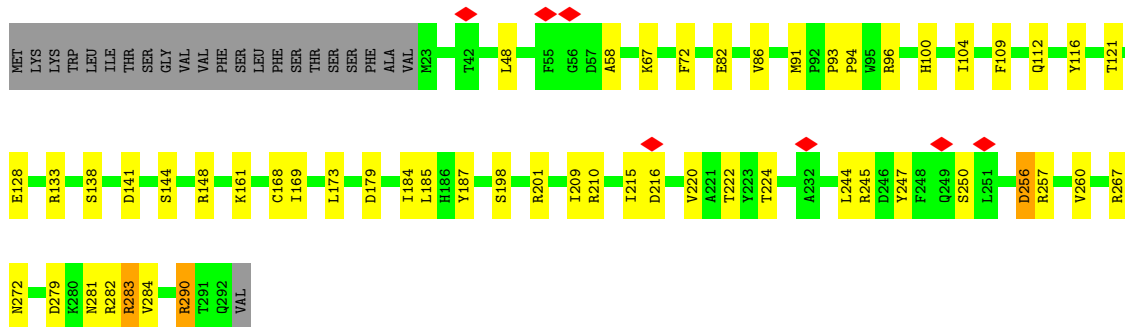
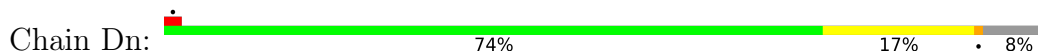

• Molecule 18: Component of sodium-driven polar flagellar motor

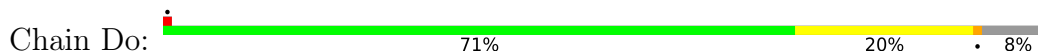

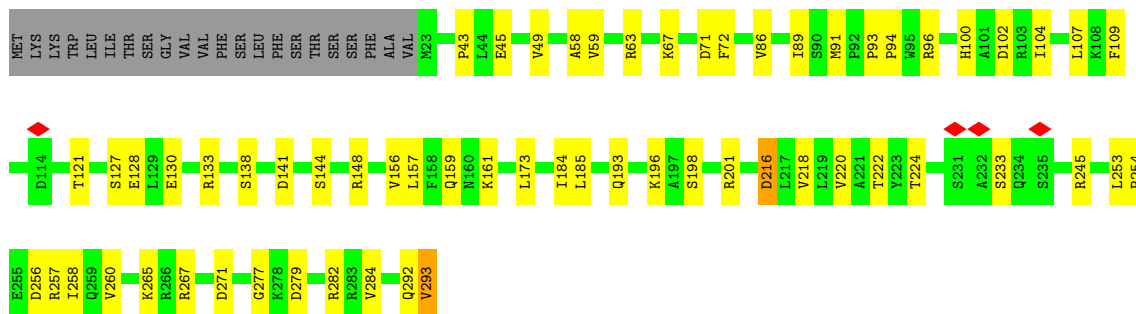

• Molecule 18: Component of sodium-driven polar flagellar motor

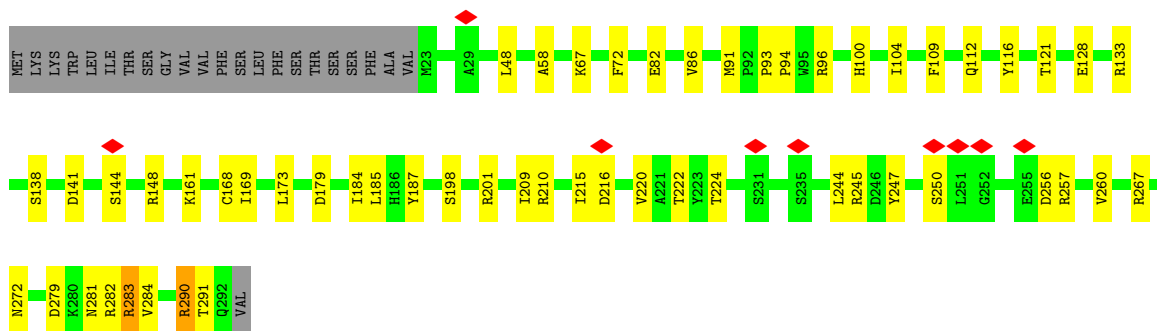
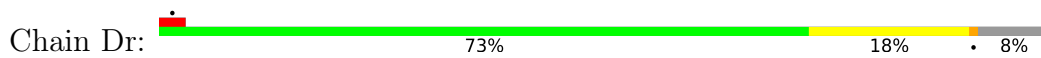

• Molecule 18: Component of sodium-driven polar flagellar motor

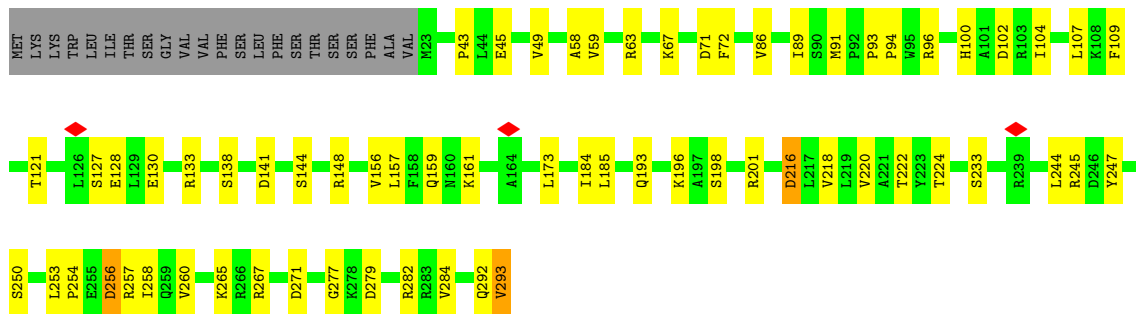

• Molecule 18: Component of sodium-driven polar flagellar motor

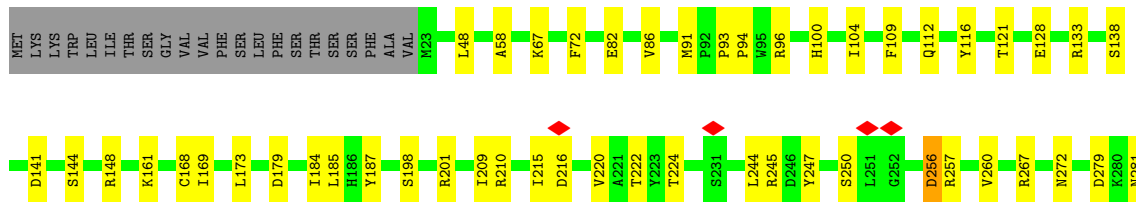
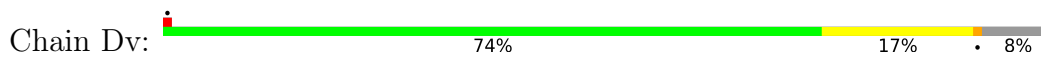



• Molecule 18: Component of sodium-driven polar flagellar motor

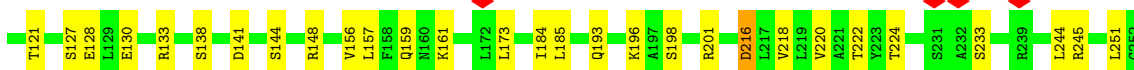
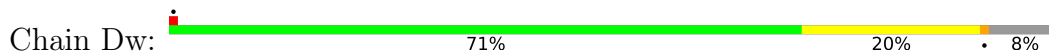

• Molecule 19: Sodium-type flagellar motor component

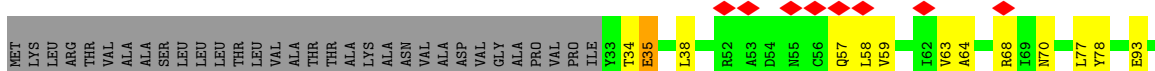

• Molecule 19: Sodium-type flagellar motor component

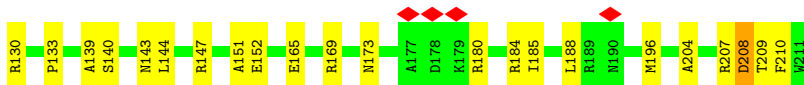
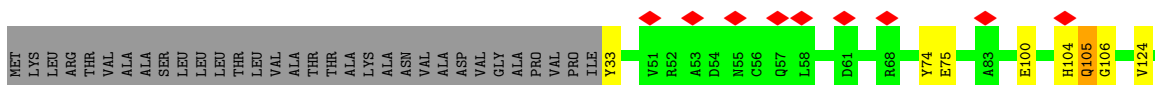
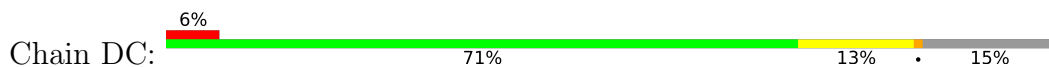

• Molecule 19: Sodium-type flagellar motor component

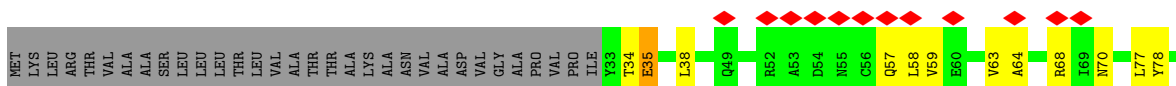

• Molecule 19: Sodium-type flagellar motor component

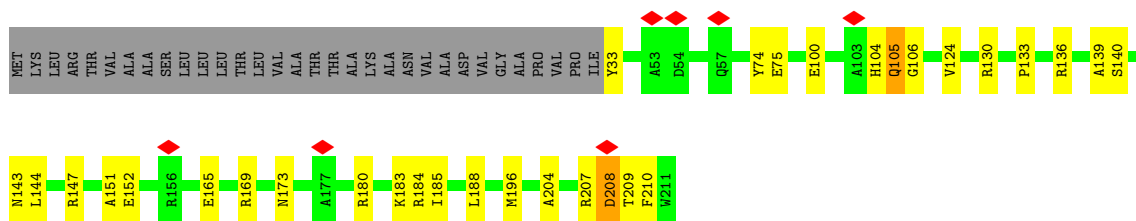
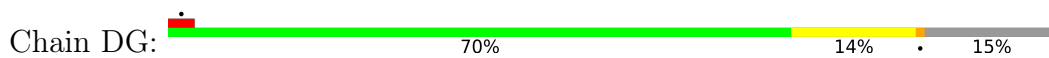

• Molecule 19: Sodium-type flagellar motor component

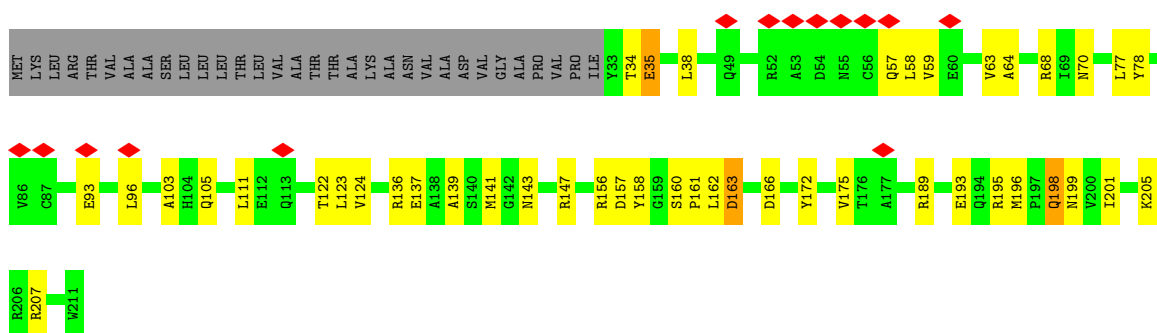

• Molecule 19: Sodium-type flagellar motor component

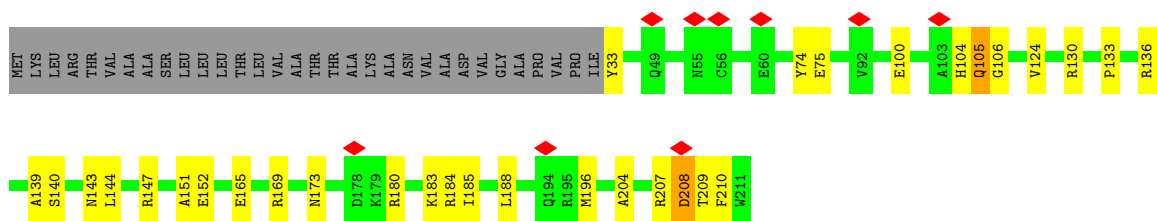

• Molecule 19: Sodium-type flagellar motor component

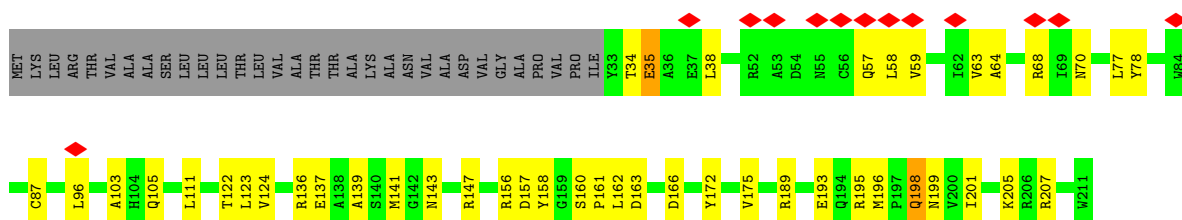

• Molecule 19: Sodium-type flagellar motor component

Chain DO:  71% 13% 15%

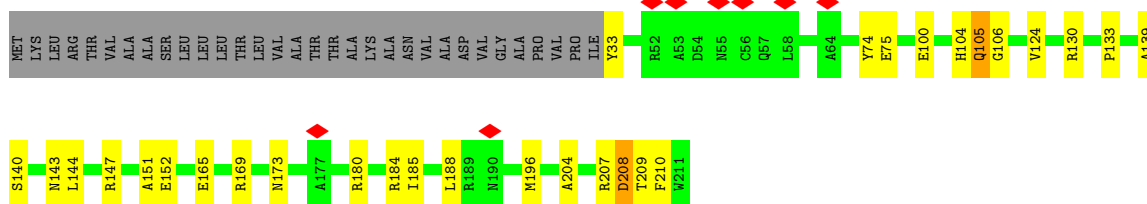

• Molecule 19: Sodium-type flagellar motor component

Chain DR:  8% 63% 21% 15%

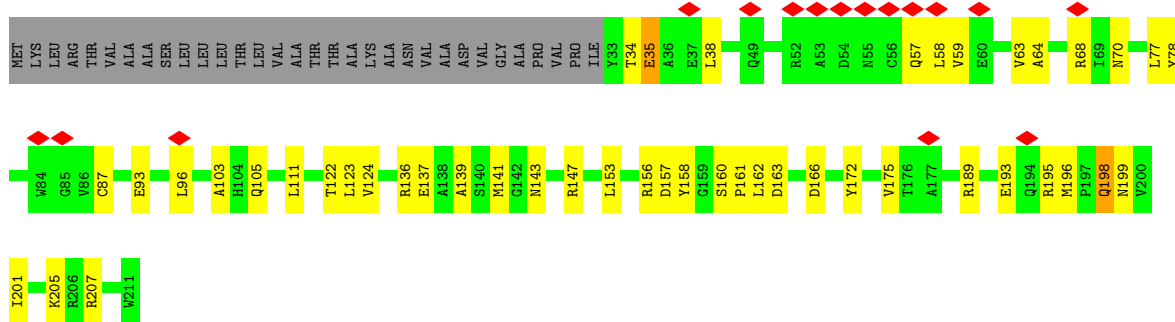

• Molecule 19: Sodium-type flagellar motor component

Chain DS:  5% 69% 15% 15%

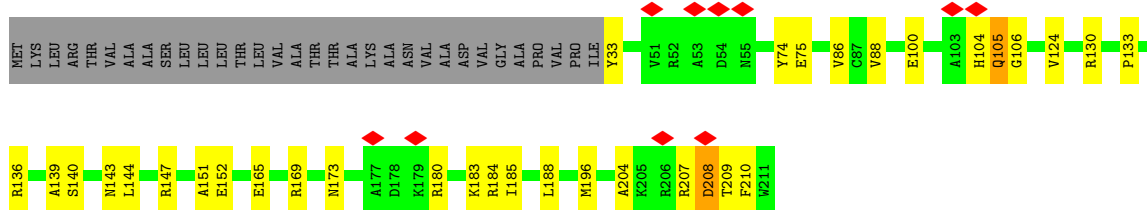

• Molecule 19: Sodium-type flagellar motor component

Chain DV:  5% 63% 21% 15%

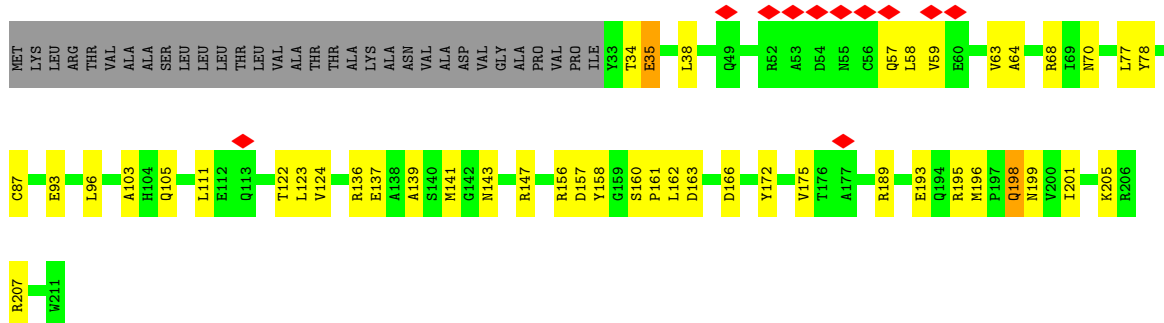

• Molecule 19: Sodium-type flagellar motor component

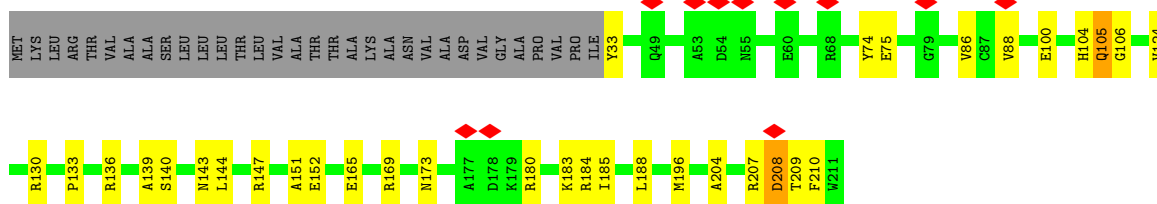
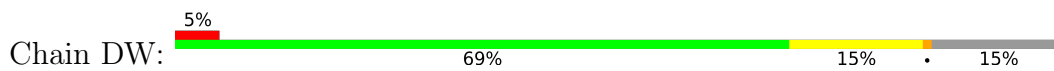

• Molecule 19: Sodium-type flagellar motor component

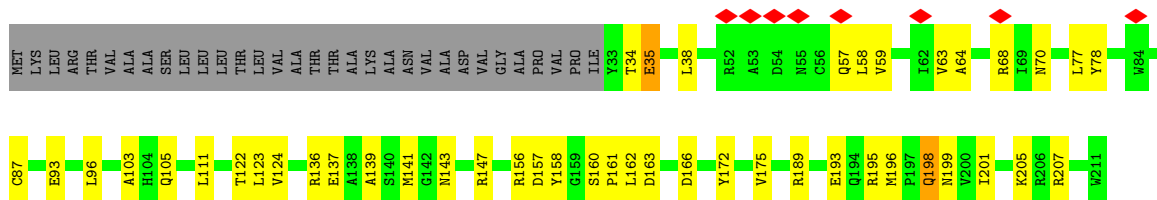

• Molecule 19: Sodium-type flagellar motor component

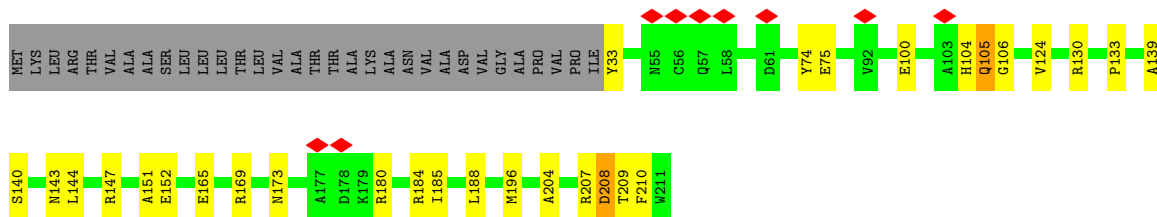

• Molecule 19: Sodium-type flagellar motor component

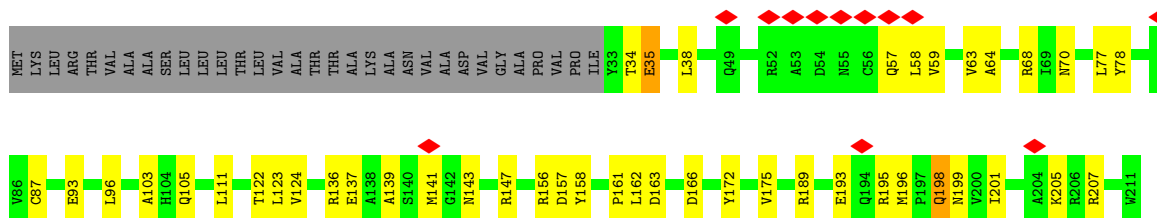

• Molecule 19: Sodium-type flagellar motor component

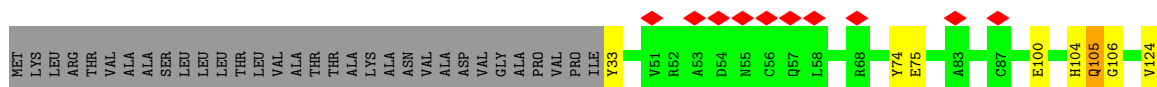



• Molecule 19: Sodium-type flagellar motor component

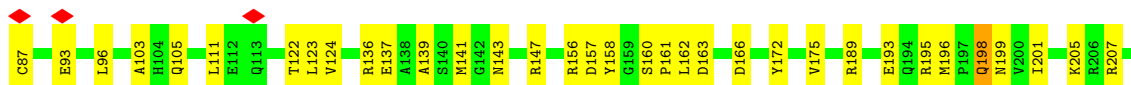
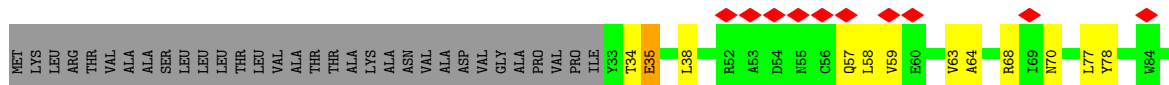

• Molecule 19: Sodium-type flagellar motor component

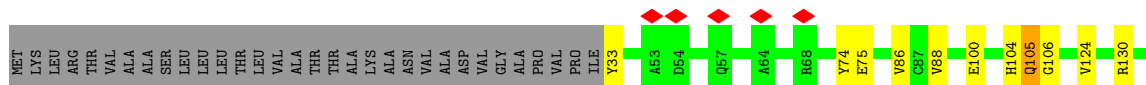

• Molecule 19: Sodium-type flagellar motor component

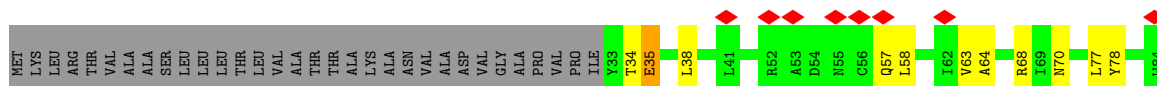

• Molecule 19: Sodium-type flagellar motor component

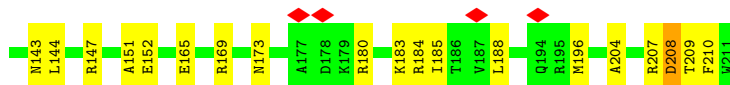
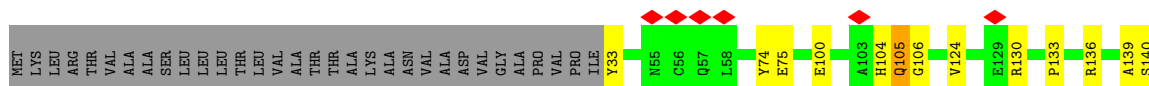

• Molecule 19: Sodium-type flagellar motor component

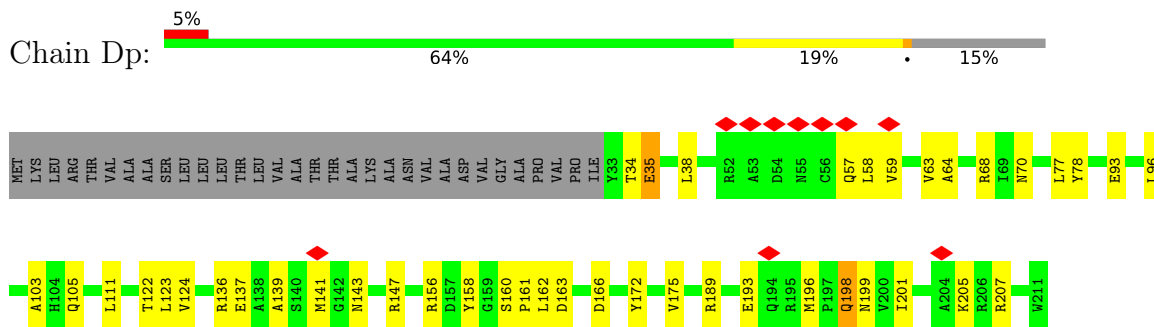

• Molecule 19: Sodium-type flagellar motor component

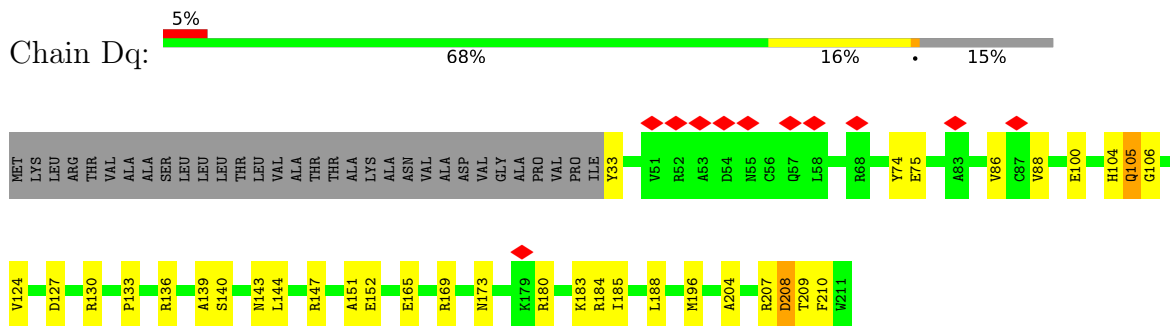

• Molecule 19: Sodium-type flagellar motor component

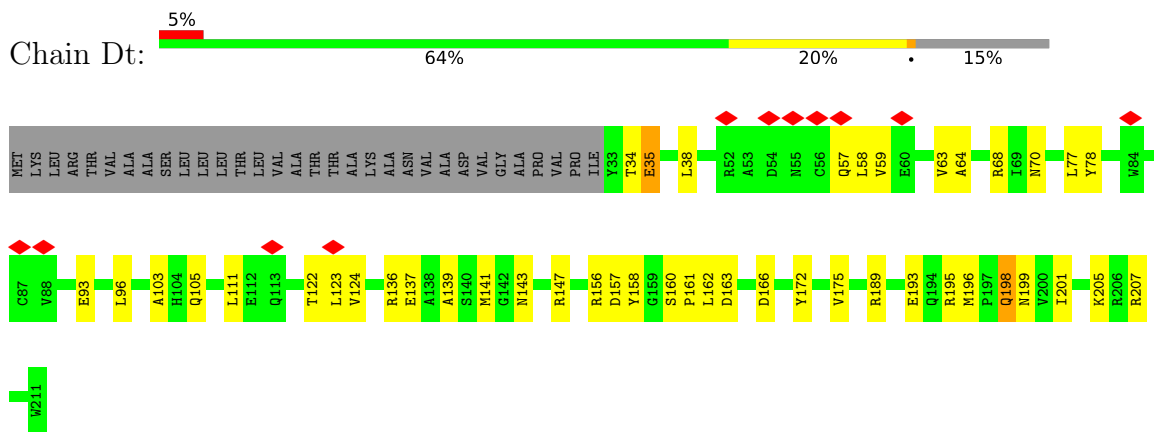

• Molecule 19: Sodium-type flagellar motor component

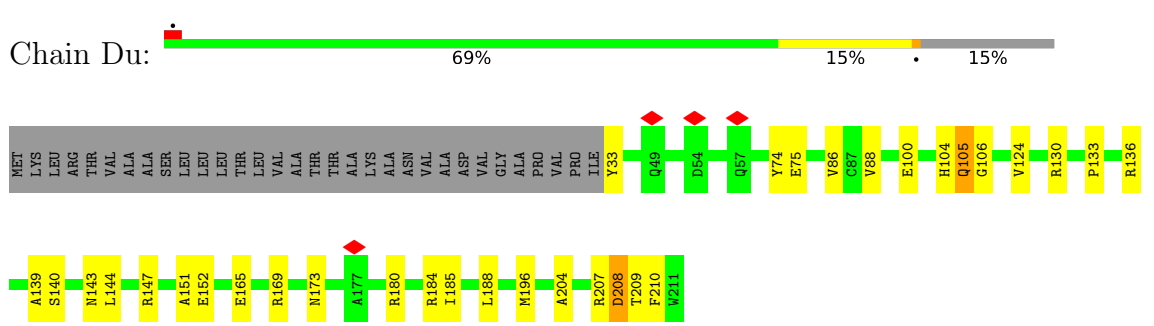

• Molecule 19: Sodium-type flagellar motor component

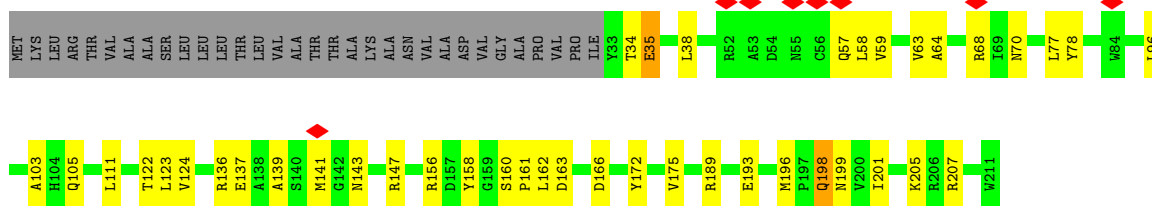

• Molecule 19: Sodium-type flagellar motor component

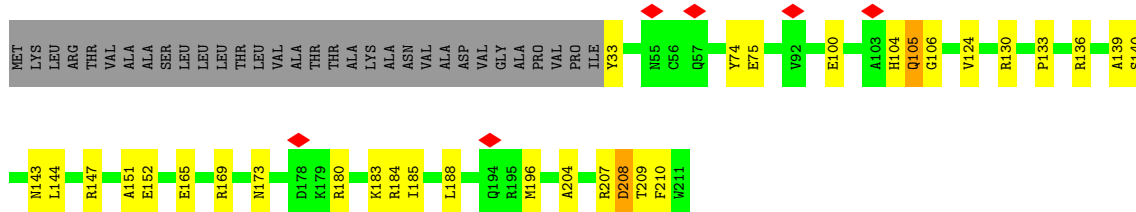

• Molecule 20: FlgB-Dc

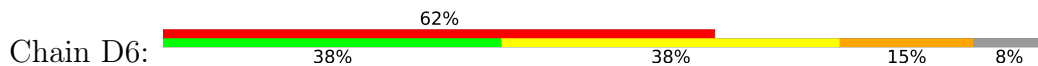

• Molecule 20: FlgB-Dc

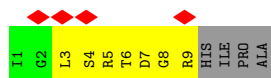
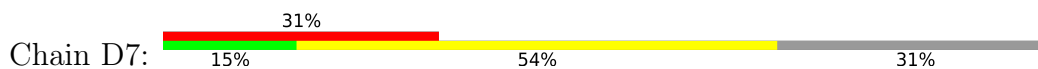

• Molecule 20: FlgB-Dc

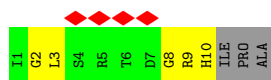

• Molecule 20: FlgB-Dc

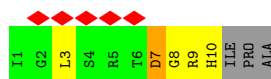

- Molecule 21: FliE-helix 1

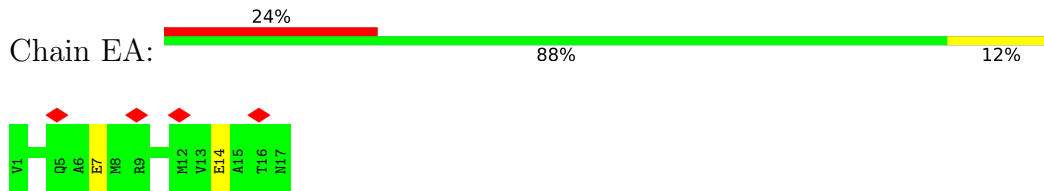

- Molecule 21: FliE-helix 1

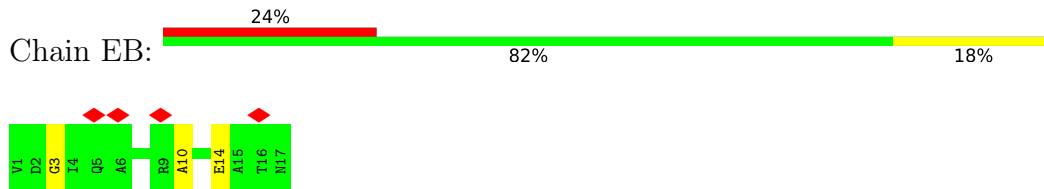

- Molecule 21: FliE-helix 1

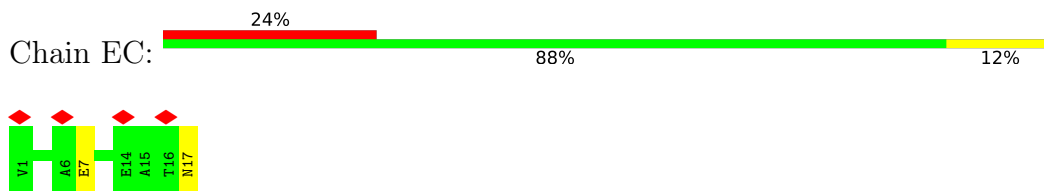

- Molecule 21: FliE-helix 1

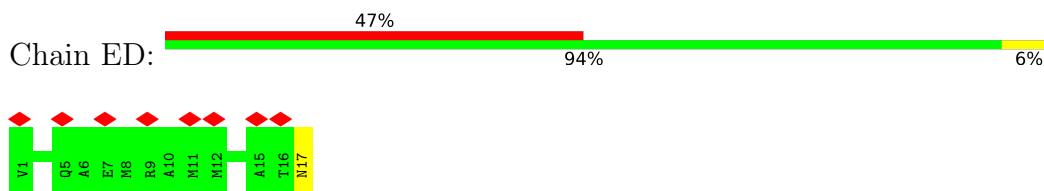

- Molecule 21: FliE-helix 1

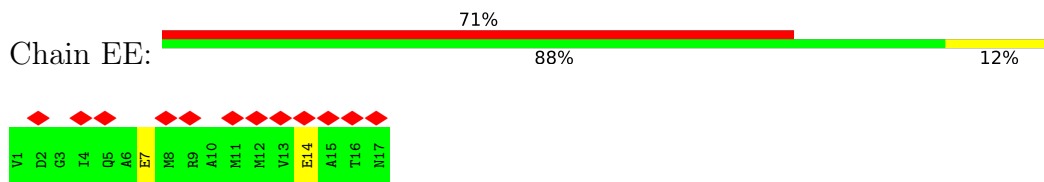

- Molecule 21: FliE-helix 1

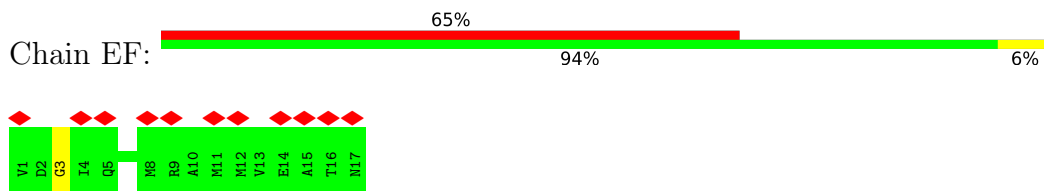

4 Experimental information

Property	Value	Source
EM reconstruction method	SINGLE PARTICLE	Depositor
Imposed symmetry	POINT, C100	Depositor
Number of particles used	61395	Depositor
Resolution determination method	FSC 0.143 CUT-OFF	Depositor
CTF correction method	PHASE FLIPPING AND AMPLITUDE CORRECTION	Depositor
Microscope	TFS KRIOS	Depositor
Voltage (kV)	300	Depositor
Electron dose ($e^-/\text{\AA}^2$)	50	Depositor
Minimum defocus (nm)	1200	Depositor
Maximum defocus (nm)	1800	Depositor
Magnification	105000	Depositor
Image detector	FEI FALCON IV (4k x 4k)	Depositor
Maximum map value	1.146	Depositor
Minimum map value	-1.007	Depositor
Average map value	0.002	Depositor
Map value standard deviation	0.036	Depositor
Recommended contour level	0.05	Depositor
Map size (Å)	744.0, 744.0, 744.0	wwPDB
Map dimensions	620, 620, 620	wwPDB
Map angles (°)	90.0, 90.0, 90.0	wwPDB
Pixel spacing (Å)	1.2, 1.2, 1.2	Depositor

5 Model quality [i](#)

5.1 Standard geometry [i](#)

Bond lengths and bond angles in the following residue types are not validated in this section: XKP, PGT

The Z score for a bond length (or angle) is the number of standard deviations the observed value is removed from the expected value. A bond length (or angle) with $|Z| > 5$ is considered an outlier worth inspection. RMSZ is the root-mean-square of all Z scores of the bond lengths (or angles).

Mol	Chain	Bond lengths		Bond angles	
		RMSZ	# Z >5	RMSZ	# Z >5
1	0	0.10	0/1389	0.27	0/1884
1	9	0.10	0/1389	0.28	0/1884
2	1	0.13	0/1628	0.30	0/2209
2	2	0.16	0/1637	0.33	0/2221
2	3	0.10	0/1637	0.26	0/2221
2	y	0.10	0/1637	0.27	0/2221
2	z	0.11	0/1637	0.28	0/2221
3	4	0.12	0/739	0.31	0/1005
3	5	0.16	0/739	0.34	0/1005
3	6	0.28	0/739	0.49	0/1005
3	7	0.15	0/739	0.33	0/1005
4	8	0.09	0/1941	0.25	0/2631
5	A	0.16	0/1985	0.33	0/2697
5	AP	0.15	0/1985	0.34	1/2697 (0.0%)
5	AQ	0.10	0/1985	0.24	0/2697
5	AR	0.14	0/1884	0.28	0/2558
5	AS	0.13	0/1884	0.29	0/2558
5	AT	0.12	0/1892	0.25	0/2568
5	AU	0.11	0/1884	0.25	0/2558
5	AV	0.10	0/1884	0.24	0/2558
5	AW	0.11	0/1985	0.26	0/2697
5	AX	0.11	0/1985	0.26	0/2697
5	AY	0.10	0/1985	0.25	0/2697
5	AZ	0.10	0/1985	0.24	0/2697
5	Aa	0.10	0/1985	0.25	0/2697
5	B	0.14	0/1985	0.32	0/2697
5	C	0.10	0/1985	0.24	0/2697
5	P	0.11	0/1985	0.25	0/2697
5	Q	0.21	1/1985 (0.1%)	0.28	0/2697
5	R	0.11	0/1985	0.25	0/2697
5	S	0.11	0/1985	0.24	0/2697
5	T	0.11	0/1985	0.24	0/2697

Mol	Chain	Bond lengths		Bond angles	
		RMSZ	# Z >5	RMSZ	# Z >5
5	U	0.22	0/1985	0.37	3/2697 (0.1%)
5	V	0.11	0/1985	0.25	0/2697
5	W	0.24	1/1985 (0.1%)	0.39	0/2697
5	X	0.11	0/1985	0.25	0/2697
5	Y	0.11	0/1985	0.25	0/2697
5	Z	0.11	0/1985	0.25	0/2697
5	a	0.11	0/1985	0.24	0/2697
6	A1	0.27	0/3385	0.47	4/4605 (0.1%)
6	A2	0.26	0/3385	0.45	4/4605 (0.1%)
6	A3	0.23	0/3385	0.41	2/4605 (0.0%)
6	Ab	0.23	0/3385	0.33	0/4605
6	Ac	0.22	0/3385	0.32	0/4605
6	Ad	0.23	0/3385	0.33	0/4605
6	Ae	0.22	0/3385	0.32	0/4605
6	Af	0.22	0/3385	0.32	0/4605
6	Ag	0.22	0/3385	0.33	0/4605
6	Ah	0.22	0/3385	0.32	0/4605
6	Ai	0.21	0/3385	0.32	0/4605
6	Aj	0.22	0/3385	0.32	0/4605
6	Ak	0.21	0/3385	0.31	0/4605
6	Al	0.21	0/3385	0.31	0/4605
6	Am	0.22	0/3385	0.32	0/4605
6	An	0.20	0/3385	0.32	0/4605
6	Ao	0.27	0/3385	0.41	1/4605 (0.0%)
6	Ap	0.27	0/3385	0.40	1/4605 (0.0%)
6	Aq	0.26	0/3385	0.43	2/4605 (0.0%)
6	Ar	0.27	0/3385	0.41	0/4605
6	As	0.26	0/3385	0.42	3/4605 (0.1%)
6	At	0.28	1/3385 (0.0%)	0.44	2/4605 (0.0%)
6	Au	0.29	0/3385	0.44	1/4605 (0.0%)
6	Av	0.29	0/3385	0.45	3/4605 (0.1%)
6	Aw	0.27	0/3385	0.42	2/4605 (0.0%)
6	Ax	0.26	0/3385	0.43	3/4605 (0.1%)
6	Ay	0.26	0/3385	0.41	1/4605 (0.0%)
6	Az	0.28	0/3385	0.46	3/4605 (0.1%)
6	D	0.23	0/3385	0.34	0/4605
6	E	0.24	0/3385	0.34	0/4605
6	F	0.23	0/3385	0.34	0/4605
6	G	0.23	0/3385	0.34	0/4605
6	H	0.23	0/3385	0.33	0/4605
6	I	0.23	0/3385	0.33	0/4605
6	J	0.23	0/3385	0.33	0/4605
6	K	0.23	0/3385	0.33	0/4605

Mol	Chain	Bond lengths		Bond angles	
		RMSZ	# Z >5	RMSZ	# Z >5
6	L	0.23	0/3385	0.33	0/4605
6	M	0.23	0/3385	0.33	0/4605
6	N	0.23	0/3385	0.33	0/4605
6	O	0.22	0/3385	0.33	0/4605
7	AA	0.35	0/137	0.45	0/188
7	AB	0.29	0/137	0.43	0/188
7	AC	0.14	0/141	0.31	0/193
7	AD	0.31	0/137	0.46	0/188
7	AE	0.12	0/137	0.28	0/188
7	AF	0.92	0/161	1.23	0/221
7	AG	0.16	0/75	0.32	0/103
7	AH	0.20	0/75	0.42	0/103
7	AI	0.95	0/75	1.34	0/103
7	AJ	0.37	0/166	0.57	0/228
7	AK	0.32	0/172	0.69	0/237
7	AL	0.39	0/223	0.61	0/304
7	AM	0.19	0/227	0.44	0/309
7	AN	0.23	0/227	0.49	0/309
7	AO	0.16	0/223	0.40	0/304
7	D1	0.16	0/1182	0.27	0/1588
7	D2	0.16	0/1182	0.27	0/1588
7	D3	0.16	0/1182	0.27	0/1588
7	D4	0.16	0/1182	0.27	0/1588
7	D5	0.16	0/1182	0.27	0/1588
7	Dz	0.16	0/1182	0.27	0/1588
7	E1	0.16	0/1182	0.27	0/1588
7	E2	0.16	0/1182	0.27	0/1588
7	E3	0.16	0/1182	0.27	0/1588
7	E4	0.16	0/1182	0.27	0/1588
7	E5	0.16	0/1182	0.27	0/1588
7	EG	0.16	0/1182	0.27	0/1588
7	EH	0.16	0/1182	0.27	0/1588
7	EI	0.16	0/1182	0.27	0/1588
7	EJ	0.16	0/1182	0.27	0/1588
7	EK	0.16	0/1182	0.27	0/1588
7	EL	0.16	0/1182	0.27	0/1588
7	EM	0.17	0/1182	0.27	0/1588
7	EN	0.16	0/1182	0.27	0/1588
7	EO	0.16	0/1182	0.27	0/1588
7	EP	0.16	0/1182	0.27	0/1588
7	EQ	0.17	0/1182	0.27	0/1588
7	ER	0.16	0/1182	0.27	0/1588
7	ES	0.16	0/1182	0.27	0/1588

Mol	Chain	Bond lengths		Bond angles	
		RMSZ	# Z >5	RMSZ	# Z >5
7	ET	0.16	0/1182	0.27	0/1588
7	EU	0.16	0/1182	0.27	0/1588
7	EV	0.16	0/1182	0.27	0/1588
7	EW	0.16	0/1182	0.27	0/1588
7	EX	0.33	0/888	0.56	0/1192
7	EY	0.30	0/888	0.44	0/1192
7	EZ	0.21	0/888	0.38	0/1192
7	Ea	0.22	0/888	0.40	0/1192
7	Eb	0.21	0/888	0.41	0/1192
7	Ec	0.23	0/844	0.41	0/1131
7	Ed	0.29	0/888	0.48	0/1192
7	Ee	0.29	0/888	0.44	0/1192
7	Ef	0.21	0/888	0.40	0/1192
7	Eg	0.22	0/727	0.40	0/974
7	Eh	0.26	0/810	0.44	0/1087
7	Ei	0.27	0/810	0.44	0/1087
7	Ej	0.17	0/810	0.38	0/1087
7	Ek	0.14	0/661	0.31	0/884
7	El	0.14	0/706	0.35	0/946
7	Em	0.15	0/697	0.34	0/934
7	En	0.14	0/685	0.33	0/917
7	Eo	0.16	0/706	0.35	0/946
7	Ep	0.22	0/888	0.38	0/1192
7	Eq	0.25	0/888	0.45	0/1192
7	Er	0.20	0/888	0.35	0/1192
7	Es	0.20	0/805	0.38	0/1078
7	Et	0.20	0/888	0.40	0/1192
7	Eu	0.16	0/1182	0.27	0/1588
7	Ev	0.16	0/1182	0.27	0/1588
7	Ew	0.16	0/1182	0.27	0/1588
7	Ex	0.16	0/1182	0.27	0/1588
7	Ey	0.16	0/1182	0.27	0/1588
7	Ez	0.16	0/1182	0.27	0/1588
8	b	0.22	0/856	0.36	0/1151
8	c	0.22	0/846	0.31	0/1138
8	d	0.24	0/856	0.31	0/1151
8	e	0.19	0/848	0.31	0/1140
8	f	0.22	0/848	0.35	0/1140
9	g	0.11	0/996	0.26	0/1348
9	h	0.10	0/996	0.26	0/1348
9	i	0.30	0/996	0.46	0/1348
9	j	0.10	0/996	0.24	0/1348
9	k	0.11	0/996	0.28	0/1348

Mol	Chain	Bond lengths		Bond angles	
		RMSZ	# Z >5	RMSZ	# Z >5
9	l	0.13	0/996	0.30	0/1348
10	m	0.11	0/1905	0.26	0/2572
10	n	0.13	0/1905	0.26	0/2572
10	o	0.10	0/1905	0.26	0/2572
10	p	0.17	0/1905	0.36	1/2572 (0.0%)
10	q	0.10	0/1905	0.25	0/2572
11	r	0.32	0/564	0.43	0/759
11	s	0.08	0/609	0.20	0/819
11	t	0.07	0/609	0.17	0/819
11	u	0.07	0/564	0.16	0/759
11	v	0.07	0/564	0.18	0/759
11	w	0.09	0/313	0.19	0/420
12	x	0.08	0/562	0.19	0/760
13	A8	0.18	0/2818	0.28	0/3814
13	B1	0.18	0/2818	0.28	0/3814
13	B6	0.18	0/2818	0.28	0/3814
13	B7	0.18	0/2818	0.28	0/3814
13	BC	0.18	0/2818	0.28	0/3814
13	BH	0.18	0/2818	0.28	0/3814
13	BM	0.18	0/2818	0.28	0/3814
13	BR	0.18	0/2818	0.28	0/3814
13	BW	0.18	0/2818	0.28	0/3814
13	Bb	0.18	0/2818	0.28	0/3814
13	Bg	0.18	0/2818	0.28	0/3814
13	Bl	0.18	0/2818	0.28	0/3814
13	Bq	0.18	0/2818	0.28	0/3814
13	Bv	0.18	0/2818	0.28	0/3814
13	C3	0.18	0/2818	0.28	0/3814
13	C8	0.18	0/2818	0.28	0/3814
13	CB	0.18	0/2818	0.28	0/3814
13	CJ	0.18	0/2818	0.28	0/3814
13	CO	0.18	0/2818	0.28	0/3814
13	CT	0.18	0/2818	0.28	0/3814
13	CY	0.18	0/2818	0.28	0/3814
13	Cd	0.18	0/2818	0.28	0/3814
13	Ci	0.18	0/2818	0.28	0/3814
13	Cn	0.18	0/2818	0.28	0/3814
13	Cs	0.18	0/2818	0.28	0/3814
13	Cx	0.18	0/2818	0.28	0/3814
14	A4	0.18	0/1706	0.29	0/2315
14	A9	0.18	0/1706	0.29	0/2315
14	B2	0.18	0/1706	0.29	0/2315
14	B8	0.18	0/1706	0.29	0/2315

Mol	Chain	Bond lengths		Bond angles	
		RMSZ	# Z >5	RMSZ	# Z >5
14	BD	0.18	0/1706	0.29	0/2315
14	BI	0.18	0/1706	0.29	0/2315
14	BN	0.18	0/1706	0.29	0/2315
14	BS	0.18	0/1706	0.29	0/2315
14	BX	0.18	0/1706	0.29	0/2315
14	Bc	0.18	0/1706	0.29	0/2315
14	Bh	0.18	0/1706	0.29	0/2315
14	Bm	0.18	0/1706	0.29	0/2315
14	Br	0.18	0/1706	0.29	0/2315
14	Bw	0.18	0/1706	0.29	0/2315
14	C4	0.18	0/1706	0.29	0/2315
14	C9	0.18	0/1706	0.29	0/2315
14	CC	0.18	0/1706	0.29	0/2315
14	CK	0.18	0/1706	0.29	0/2315
14	CP	0.18	0/1706	0.29	0/2315
14	CU	0.18	0/1706	0.29	0/2315
14	CZ	0.18	0/1706	0.29	0/2315
14	Ce	0.18	0/1706	0.29	0/2315
14	Cj	0.18	0/1706	0.29	0/2315
14	Co	0.18	0/1706	0.29	0/2315
14	Ct	0.18	0/1706	0.29	0/2315
14	Cy	0.18	0/1706	0.29	0/2315
15	A0	0.23	0/98	0.39	0/129
15	A5	0.23	0/98	0.39	0/129
15	B3	0.24	0/98	0.39	0/129
15	B9	0.23	0/98	0.38	0/129
15	BE	0.23	0/98	0.39	0/129
15	BJ	0.24	0/98	0.38	0/129
15	BO	0.24	0/98	0.39	0/129
15	BT	0.23	0/98	0.39	0/129
15	BY	0.23	0/98	0.39	0/129
15	Bd	0.23	0/98	0.38	0/129
15	Bi	0.23	0/98	0.39	0/129
15	Bn	0.23	0/98	0.38	0/129
15	Bs	0.24	0/98	0.39	0/129
15	Bx	0.23	0/98	0.39	0/129
15	C0	0.23	0/98	0.39	0/129
15	C5	0.23	0/98	0.39	0/129
15	CD	0.23	0/98	0.39	0/129
15	CL	0.23	0/98	0.39	0/129
15	CQ	0.24	0/98	0.38	0/129
15	CV	0.23	0/98	0.39	0/129
15	Ca	0.23	0/98	0.39	0/129

Mol	Chain	Bond lengths		Bond angles	
		RMSZ	# Z >5	RMSZ	# Z >5
15	Cf	0.23	0/98	0.39	0/129
15	Ck	0.23	0/98	0.39	0/129
15	Cp	0.23	0/98	0.39	0/129
15	Cu	0.23	0/98	0.38	0/129
15	Cz	0.24	0/98	0.39	0/129
16	A6	0.34	0/64	0.99	1/88 (1.1%)
16	B0	0.34	0/64	0.99	1/88 (1.1%)
16	B4	0.35	0/64	0.99	1/88 (1.1%)
16	BA	0.35	0/64	0.99	1/88 (1.1%)
16	BF	0.34	0/64	0.99	1/88 (1.1%)
16	BK	0.34	0/64	0.99	1/88 (1.1%)
16	BP	0.34	0/64	1.00	1/88 (1.1%)
16	BU	0.34	0/64	0.99	1/88 (1.1%)
16	BZ	0.34	0/64	0.98	1/88 (1.1%)
16	Be	0.34	0/64	0.99	1/88 (1.1%)
16	Bj	0.34	0/64	0.99	1/88 (1.1%)
16	Bo	0.35	0/64	0.99	1/88 (1.1%)
16	Bt	0.34	0/64	0.99	1/88 (1.1%)
16	By	0.34	0/64	0.98	1/88 (1.1%)
16	C1	0.34	0/64	0.99	1/88 (1.1%)
16	C6	0.34	0/64	0.99	1/88 (1.1%)
16	CE	0.35	0/64	0.99	1/88 (1.1%)
16	CH	0.35	0/64	1.00	1/88 (1.1%)
16	CM	0.34	0/64	0.99	1/88 (1.1%)
16	CR	0.34	0/64	0.98	1/88 (1.1%)
16	CW	0.34	0/64	1.00	1/88 (1.1%)
16	Cb	0.34	0/64	0.99	1/88 (1.1%)
16	Cg	0.34	0/64	0.98	1/88 (1.1%)
16	Cl	0.34	0/64	0.99	1/88 (1.1%)
16	Cq	0.34	0/64	0.99	1/88 (1.1%)
16	Cv	0.34	0/64	0.99	1/88 (1.1%)
16	D0	1.20	0/64	1.44	1/88 (1.1%)
17	A7	0.18	0/2131	0.27	0/2894
17	B5	0.19	0/2131	0.27	0/2894
17	BB	0.19	0/2131	0.27	0/2894
17	BG	0.19	0/2131	0.27	0/2894
17	BL	0.19	0/2131	0.27	0/2894
17	BQ	0.19	0/2131	0.27	0/2894
17	BV	0.19	0/2131	0.27	0/2894
17	Ba	0.19	0/2131	0.28	0/2894
17	Bf	0.19	0/2131	0.27	0/2894
17	Bk	0.19	0/2131	0.27	0/2894
17	Bp	0.19	0/2131	0.27	0/2894

Mol	Chain	Bond lengths		Bond angles	
		RMSZ	# Z >5	RMSZ	# Z >5
17	Bu	0.19	0/2131	0.27	0/2894
17	Bz	0.19	0/2131	0.27	0/2894
17	C2	0.19	0/2131	0.27	0/2894
17	C7	0.19	0/2131	0.27	0/2894
17	CA	0.18	0/2131	0.27	0/2894
17	CF	0.19	0/2131	0.27	0/2894
17	CI	0.19	0/2131	0.27	0/2894
17	CN	0.19	0/2131	0.27	0/2894
17	CS	0.19	0/2131	0.27	0/2894
17	CX	0.19	0/2131	0.27	0/2894
17	Cc	0.19	0/2131	0.27	0/2894
17	Ch	0.19	0/2131	0.27	0/2894
17	Cm	0.19	0/2131	0.27	0/2894
17	Cr	0.19	0/2131	0.27	0/2894
17	Cw	0.19	0/2131	0.27	0/2894
18	CG	0.23	0/2230	0.35	0/3009
18	DA	0.22	0/2237	0.35	0/3019
18	DD	0.23	0/2230	0.35	0/3009
18	DE	0.22	0/2237	0.35	0/3019
18	DH	0.23	0/2230	0.35	0/3009
18	DI	0.22	0/2237	0.36	0/3019
18	DL	0.23	0/2230	0.35	0/3009
18	DM	0.22	0/2237	0.35	0/3019
18	DP	0.23	0/2230	0.35	0/3009
18	DQ	0.22	0/2237	0.36	0/3019
18	DT	0.23	0/2230	0.35	0/3009
18	DU	0.22	0/2237	0.35	0/3019
18	DX	0.23	0/2230	0.35	0/3009
18	DY	0.22	0/2237	0.35	0/3019
18	Db	0.23	0/2230	0.35	0/3009
18	Dc	0.22	0/2237	0.36	0/3019
18	Df	0.23	0/2230	0.35	0/3009
18	Dg	0.22	0/2237	0.36	0/3019
18	Dj	0.23	0/2230	0.35	0/3009
18	Dk	0.22	0/2237	0.35	0/3019
18	Dn	0.23	0/2230	0.35	0/3009
18	Do	0.22	0/2237	0.36	0/3019
18	Dr	0.23	0/2230	0.35	0/3009
18	Ds	0.22	0/2237	0.35	0/3019
18	Dv	0.23	0/2230	0.35	0/3009
18	Dw	0.22	0/2237	0.36	0/3019
19	DB	0.15	0/1499	0.39	0/2029
19	DC	0.17	0/1499	0.38	0/2029

Mol	Chain	Bond lengths		Bond angles	
		RMSZ	# Z >5	RMSZ	# Z >5
19	DF	0.16	0/1499	0.39	0/2029
19	DG	0.17	0/1499	0.38	0/2029
19	DJ	0.16	0/1499	0.39	0/2029
19	DK	0.17	0/1499	0.38	0/2029
19	DN	0.16	0/1499	0.39	0/2029
19	DO	0.17	0/1499	0.38	0/2029
19	DR	0.16	0/1499	0.39	0/2029
19	DS	0.17	0/1499	0.38	0/2029
19	DV	0.16	0/1499	0.39	0/2029
19	DW	0.17	0/1499	0.38	0/2029
19	DZ	0.15	0/1499	0.39	0/2029
19	Da	0.17	0/1499	0.38	0/2029
19	Dd	0.16	0/1499	0.39	0/2029
19	De	0.17	0/1499	0.38	0/2029
19	Dh	0.16	0/1499	0.39	0/2029
19	Di	0.17	0/1499	0.38	0/2029
19	Dl	0.16	0/1499	0.39	0/2029
19	Dm	0.17	0/1499	0.38	0/2029
19	Dp	0.16	0/1499	0.39	0/2029
19	Dq	0.17	0/1499	0.38	0/2029
19	Dt	0.16	0/1499	0.39	0/2029
19	Du	0.17	0/1499	0.38	0/2029
19	Dx	0.16	0/1499	0.39	0/2029
19	Dy	0.17	0/1499	0.38	0/2029
20	D6	1.15	0/57	1.40	1/77 (1.3%)
20	D7	1.27	0/42	1.22	0/56
20	D8	1.16	0/47	1.30	0/63
20	D9	1.09	0/47	1.29	0/63
21	EA	1.12	0/83	1.44	0/114
21	EB	1.11	0/83	1.44	0/114
21	EC	1.12	0/83	1.45	0/114
21	ED	1.10	0/83	1.45	0/114
21	EE	1.11	0/83	1.45	0/114
21	EF	1.11	0/83	1.44	0/114
All	All	0.20	3/564349 (0.0%)	0.33	65/764531 (0.0%)

Chiral center outliers are detected by calculating the chiral volume of a chiral center and verifying if the center is modelled as a planar moiety or with the opposite hand. A planarity outlier is detected by checking planarity of atoms in a peptide group, atoms in a mainchain group or atoms of a sidechain that are expected to be planar.

Mol	Chain	#Chirality outliers	#Planarity outliers
2	2	0	1

Continued on next page...

Continued from previous page...

Mol	Chain	#Chirality outliers	#Planarity outliers
5	AP	0	2
6	A1	0	1
6	A2	0	1
6	Ay	0	1
6	Az	0	1
7	EY	0	1
7	Eh	0	1
7	Ei	0	1
7	Eq	0	1
All	All	0	11

All (3) bond length outliers are listed below:

Mol	Chain	Res	Type	Atoms	Z	Observed(Å)	Ideal(Å)
5	W	52	PRO	C-O	-5.50	1.17	1.23
5	Q	37	SER	CA-CB	-5.41	1.45	1.53
6	At	45	SER	CA-CB	-5.16	1.45	1.53

The worst 5 of 65 bond angle outliers are listed below:

Mol	Chain	Res	Type	Atoms	Z	Observed(°)	Ideal(°)
6	Az	54	PRO	N-CA-C	-12.35	92.02	111.03
6	Aq	49	ASN	CB-CA-C	-10.20	104.79	116.63
6	A1	54	PRO	N-CA-C	-10.18	95.21	111.19
6	A2	54	PRO	N-CA-C	-9.44	96.37	111.19
6	At	46	LEU	N-CA-C	-8.75	102.61	113.28

There are no chirality outliers.

5 of 11 planarity outliers are listed below:

Mol	Chain	Res	Type	Group
2	2	188	ARG	Sidechain
6	A1	353	ARG	Sidechain
6	A2	41	VAL	Mainchain
5	AP	161	ARG	Sidechain
5	AP	163	ARG	Sidechain

5.2 Too-close contacts [i](#)

In the following table, the Non-H and H(model) columns list the number of non-hydrogen atoms and hydrogen atoms in the chain respectively. The H(added) column lists the number of hydrogen

atoms added and optimized by MolProbity. The Clashes column lists the number of clashes within the asymmetric unit, whereas Symm-Clashes lists symmetry-related clashes.

Mol	Chain	Non-H	H(model)	H(added)	Clashes	Symm-Clashes
1	0	1361	0	1418	27	0
1	9	1361	0	1418	22	0
2	1	1599	0	1685	46	0
2	2	1608	0	1691	51	0
2	3	1608	0	1691	37	0
2	y	1608	0	1691	68	0
2	z	1608	0	1691	56	0
3	4	722	0	768	29	0
3	5	722	0	768	32	0
3	6	722	0	768	36	0
3	7	722	0	768	40	0
4	8	1896	0	1968	49	0
5	A	1956	0	1907	40	0
5	AP	1956	0	1907	39	0
5	AQ	1956	0	1907	31	0
5	AR	1858	0	1813	43	0
5	AS	1858	0	1813	39	0
5	AT	1866	0	1825	33	0
5	AU	1858	0	1813	39	0
5	AV	1858	0	1813	35	0
5	AW	1956	0	1907	41	0
5	AX	1956	0	1907	38	0
5	AY	1956	0	1907	83	0
5	AZ	1956	0	1907	107	0
5	Aa	1956	0	1907	86	0
5	B	1956	0	1907	42	0
5	C	1956	0	1907	37	0
5	P	1956	0	1907	110	0
5	Q	1956	0	1907	104	0
5	R	1956	0	1907	34	0
5	S	1956	0	1907	77	0
5	T	1956	0	1907	89	0
5	U	1956	0	1907	69	0
5	V	1956	0	1907	61	0
5	W	1956	0	1907	51	0
5	X	1956	0	1907	58	0
5	Y	1956	0	1907	41	0
5	Z	1956	0	1907	31	0
5	a	1956	0	1907	43	0
6	A1	3319	0	3124	90	0
6	A2	3319	0	3124	105	0

Continued on next page...

Continued from previous page...

Mol	Chain	Non-H	H(model)	H(added)	Clashes	Symm-Clashes
6	A3	3319	0	3124	106	0
6	Ab	3319	0	3124	56	0
6	Ac	3319	0	3124	64	0
6	Ad	3319	0	3124	51	0
6	Ae	3319	0	3124	47	0
6	Af	3319	0	3124	58	0
6	Ag	3319	0	3124	53	0
6	Ah	3319	0	3124	48	0
6	Ai	3319	0	3124	51	0
6	Aj	3319	0	3124	56	0
6	Ak	3319	0	3124	57	0
6	Al	3319	0	3124	42	0
6	Am	3319	0	3124	42	0
6	An	3319	0	3124	59	0
6	Ao	3319	0	3124	59	0
6	Ap	3319	0	3124	71	0
6	Aq	3319	0	3124	63	0
6	Ar	3319	0	3124	62	0
6	As	3319	0	3124	80	0
6	At	3319	0	3124	73	0
6	Au	3319	0	3124	74	0
6	Av	3319	0	3124	86	0
6	Aw	3319	0	3124	65	0
6	Ax	3319	0	3124	88	0
6	Ay	3319	0	3124	128	0
6	Az	3319	0	3124	117	0
6	D	3319	0	3124	41	0
6	E	3319	0	3124	40	0
6	F	3319	0	3124	40	0
6	G	3319	0	3124	39	0
6	H	3319	0	3124	39	0
6	I	3319	0	3124	48	0
6	J	3319	0	3124	45	0
6	K	3319	0	3124	42	0
6	L	3319	0	3124	49	0
6	M	3319	0	3124	46	0
6	N	3319	0	3124	41	0
6	O	3319	0	3124	45	0
7	AA	135	0	128	4	0
7	AB	135	0	128	3	0
7	AC	139	0	131	4	0
7	AD	135	0	128	6	0

Continued on next page...

Continued from previous page...

Mol	Chain	Non-H	H(model)	H(added)	Clashes	Symm-Clashes
7	AE	135	0	128	2	0
7	AF	158	0	152	16	0
7	AG	73	0	72	3	0
7	AH	73	0	72	4	0
7	AI	73	0	72	8	0
7	AJ	163	0	157	5	0
7	AK	169	0	164	6	0
7	AL	220	0	215	3	0
7	AM	224	0	218	5	0
7	AN	224	0	218	2	0
7	AO	220	0	215	3	0
7	D1	1171	0	1164	12	0
7	D2	1171	0	1164	14	0
7	D3	1171	0	1164	17	0
7	D4	1171	0	1164	15	0
7	D5	1171	0	1164	19	0
7	Dz	1171	0	1164	13	0
7	E1	1171	0	1164	15	0
7	E2	1171	0	1164	14	0
7	E3	1171	0	1164	22	0
7	E4	1171	0	1164	14	0
7	E5	1171	0	1164	14	0
7	EG	1171	0	1164	16	0
7	EH	1171	0	1164	13	0
7	EI	1171	0	1164	12	0
7	EJ	1171	0	1164	15	0
7	EK	1171	0	1164	24	0
7	EL	1171	0	1164	19	0
7	EM	1171	0	1164	22	0
7	EN	1171	0	1164	14	0
7	EO	1171	0	1164	14	0
7	EP	1171	0	1164	13	0
7	EQ	1171	0	1164	12	0
7	ER	1171	0	1164	18	0
7	ES	1171	0	1164	22	0
7	ET	1171	0	1164	14	0
7	EU	1171	0	1164	12	0
7	EV	1171	0	1164	12	0
7	EW	1171	0	1164	12	0
7	EX	881	0	910	60	0
7	EY	881	0	910	64	0
7	EZ	881	0	910	37	0

Continued on next page...

Continued from previous page...

Mol	Chain	Non-H	H(model)	H(added)	Clashes	Symm-Clashes
7	Ea	881	0	910	37	0
7	Eb	881	0	910	48	0
7	Ec	839	0	864	31	0
7	Ed	881	0	910	58	0
7	Ee	881	0	910	38	0
7	Ef	881	0	910	42	0
7	Eg	724	0	758	31	0
7	Eh	803	0	837	45	0
7	Ei	803	0	837	38	0
7	Ej	803	0	837	32	0
7	Ek	660	0	699	21	0
7	El	704	0	741	28	0
7	Em	695	0	735	30	0
7	En	684	0	725	31	0
7	Eo	704	0	741	29	0
7	Ep	881	0	910	60	0
7	Eq	881	0	910	40	0
7	Er	881	0	910	39	0
7	Es	802	0	836	36	0
7	Et	881	0	910	37	0
7	Eu	1171	0	1164	14	0
7	Ev	1171	0	1164	16	0
7	Ew	1171	0	1164	14	0
7	Ex	1171	0	1164	16	0
7	Ey	1171	0	1164	14	0
7	Ez	1171	0	1164	12	0
8	b	845	0	833	12	0
8	c	835	0	825	22	0
8	d	845	0	833	11	0
8	e	837	0	829	14	0
8	f	837	0	829	15	0
9	g	983	0	958	12	0
9	h	983	0	958	24	0
9	i	983	0	958	37	0
9	j	983	0	958	12	0
9	k	983	0	958	20	0
9	l	983	0	958	26	0
10	m	1879	0	1864	37	0
10	n	1879	0	1864	61	0
10	o	1879	0	1864	35	0
10	p	1879	0	1864	34	0
10	q	1879	0	1864	43	0

Continued on next page...

Continued from previous page...

Mol	Chain	Non-H	H(model)	H(added)	Clashes	Symm-Clashes
11	r	560	0	561	12	0
11	s	605	0	609	10	0
11	t	605	0	609	19	0
11	u	560	0	561	10	0
11	v	560	0	561	20	0
11	w	311	0	320	8	0
12	x	552	0	577	21	0
13	A8	2774	0	2747	73	0
13	B1	2774	0	2747	73	0
13	B6	2774	0	2747	77	0
13	B7	2774	0	2747	75	0
13	BC	2774	0	2747	71	0
13	BH	2774	0	2747	74	0
13	BM	2774	0	2747	71	0
13	BR	2774	0	2747	75	0
13	BW	2774	0	2747	72	0
13	Bb	2774	0	2747	77	0
13	Bg	2774	0	2747	77	0
13	Bl	2774	0	2747	78	0
13	Bq	2774	0	2747	72	0
13	Bv	2774	0	2747	75	0
13	C3	2774	0	2747	71	0
13	C8	2774	0	2747	74	0
13	CB	2774	0	2747	72	0
13	CJ	2774	0	2747	73	0
13	CO	2774	0	2747	68	0
13	CT	2774	0	2747	76	0
13	CY	2774	0	2747	72	0
13	Cd	2774	0	2747	76	0
13	Ci	2774	0	2747	74	0
13	Cn	2774	0	2747	78	0
13	Cs	2774	0	2747	73	0
13	Cx	2774	0	2747	74	0
14	A4	1678	0	1612	64	0
14	A9	1678	0	1612	65	0
14	B2	1678	0	1612	66	0
14	B8	1678	0	1612	66	0
14	BD	1678	0	1612	63	0
14	BI	1678	0	1612	64	0
14	BN	1678	0	1612	65	0
14	BS	1678	0	1612	68	0
14	BX	1678	0	1612	65	0

Continued on next page...

Continued from previous page...

Mol	Chain	Non-H	H(model)	H(added)	Clashes	Symm-Clashes
14	Bc	1678	0	1612	63	0
14	Bh	1678	0	1612	63	0
14	Bm	1678	0	1612	64	0
14	Br	1678	0	1612	66	0
14	Bw	1678	0	1612	66	0
14	C4	1678	0	1612	63	0
14	C9	1678	0	1612	63	0
14	CC	1678	0	1612	65	0
14	CK	1678	0	1612	65	0
14	CP	1678	0	1612	65	0
14	CU	1678	0	1612	62	0
14	CZ	1678	0	1612	65	0
14	Ce	1678	0	1612	66	0
14	Cj	1678	0	1612	63	0
14	Co	1678	0	1612	62	0
14	Ct	1678	0	1612	63	0
14	Cy	1678	0	1612	64	0
15	A0	97	0	98	6	0
15	A5	97	0	98	6	0
15	B3	97	0	98	6	0
15	B9	97	0	98	6	0
15	BE	97	0	98	6	0
15	BJ	97	0	98	6	0
15	BO	97	0	98	6	0
15	BT	97	0	98	6	0
15	BY	97	0	98	6	0
15	Bd	97	0	98	6	0
15	Bi	97	0	98	6	0
15	Bn	97	0	98	6	0
15	Bs	97	0	98	6	0
15	Bx	97	0	98	6	0
15	C0	97	0	98	6	0
15	C5	97	0	98	6	0
15	CD	97	0	98	6	0
15	CL	97	0	98	6	0
15	CQ	97	0	98	6	0
15	CV	97	0	98	6	0
15	Ca	97	0	98	6	0
15	Cf	97	0	98	6	0
15	Ck	97	0	98	6	0
15	Cp	97	0	98	6	0
15	Cu	97	0	98	6	0

Continued on next page...

Continued from previous page...

Mol	Chain	Non-H	H(model)	H(added)	Clashes	Symm-Clashes
15	Cz	97	0	98	6	0
16	A6	65	0	30	5	0
16	B0	65	0	30	5	0
16	B4	65	0	30	5	0
16	BA	65	0	30	5	0
16	BF	65	0	30	5	0
16	BK	65	0	30	5	0
16	BP	65	0	30	5	0
16	BU	65	0	30	5	0
16	BZ	65	0	30	5	0
16	Be	65	0	30	5	0
16	Bj	65	0	30	5	0
16	Bo	65	0	30	5	0
16	Bt	65	0	30	5	0
16	By	65	0	30	5	0
16	C1	65	0	30	5	0
16	C6	65	0	30	5	0
16	CE	65	0	30	5	0
16	CH	65	0	30	5	0
16	CM	65	0	30	5	0
16	CR	65	0	30	5	0
16	CW	65	0	30	5	0
16	Cb	65	0	30	5	0
16	Cg	65	0	30	5	0
16	Cl	65	0	30	5	0
16	Cq	65	0	30	5	0
16	Cv	65	0	30	5	0
16	D0	65	0	30	5	0
17	A7	2102	0	2158	42	0
17	B5	2102	0	2158	45	0
17	BB	2102	0	2158	44	0
17	BG	2102	0	2158	48	0
17	BL	2102	0	2158	42	0
17	BQ	2102	0	2158	43	0
17	BV	2102	0	2158	45	0
17	Ba	2102	0	2158	44	0
17	Bf	2102	0	2158	44	0
17	Bk	2102	0	2158	43	0
17	Bp	2102	0	2158	43	0
17	Bu	2102	0	2158	43	0
17	Bz	2102	0	2158	45	0
17	C2	2102	0	2158	44	0

Continued on next page...

Continued from previous page...

Mol	Chain	Non-H	H(model)	H(added)	Clashes	Symm-Clashes
17	C7	2102	0	2158	44	0
17	CA	2102	0	2158	49	0
17	CF	2102	0	2158	44	0
17	CI	2102	0	2158	42	0
17	CN	2102	0	2158	45	0
17	CS	2102	0	2158	45	0
17	CX	2102	0	2158	46	0
17	Cc	2102	0	2158	45	0
17	Ch	2102	0	2158	44	0
17	Cm	2102	0	2158	44	0
17	Cr	2102	0	2158	43	0
17	Cw	2102	0	2158	44	0
18	CG	2183	0	2154	32	0
18	DA	2190	0	2163	47	0
18	DD	2183	0	2154	33	0
18	DE	2190	0	2163	46	0
18	DH	2183	0	2154	32	0
18	DI	2190	0	2163	43	0
18	DL	2183	0	2154	31	0
18	DM	2190	0	2163	46	0
18	DP	2183	0	2154	34	0
18	DQ	2190	0	2163	47	0
18	DT	2183	0	2154	32	0
18	DU	2190	0	2163	49	0
18	DX	2183	0	2154	33	0
18	DY	2190	0	2163	46	0
18	Db	2183	0	2154	32	0
18	Dc	2190	0	2163	48	0
18	Df	2183	0	2154	33	0
18	Dg	2190	0	2163	48	0
18	Dj	2183	0	2154	35	0
18	Dk	2190	0	2163	45	0
18	Dn	2183	0	2154	33	0
18	Do	2190	0	2163	45	0
18	Dr	2183	0	2154	34	0
18	Ds	2190	0	2163	48	0
18	Dv	2183	0	2154	34	0
18	Dw	2190	0	2163	47	0
19	DB	1471	0	1457	28	0
19	DC	1471	0	1457	25	0
19	DF	1471	0	1457	27	0
19	DG	1471	0	1457	27	0

Continued on next page...

Continued from previous page...

Mol	Chain	Non-H	H(model)	H(added)	Clashes	Symm-Clashes
19	DJ	1471	0	1457	27	0
19	DK	1471	0	1457	27	0
19	DN	1471	0	1457	28	0
19	DO	1471	0	1457	25	0
19	DR	1471	0	1457	29	0
19	DS	1471	0	1457	28	0
19	DV	1471	0	1457	28	0
19	DW	1471	0	1457	28	0
19	DZ	1471	0	1457	28	0
19	Da	1471	0	1457	26	0
19	Dd	1471	0	1457	27	0
19	De	1471	0	1457	26	0
19	Dh	1471	0	1457	28	0
19	Di	1471	0	1457	27	0
19	Dl	1471	0	1457	27	0
19	Dm	1471	0	1457	28	0
19	Dp	1471	0	1457	27	0
19	Dq	1471	0	1457	30	0
19	Dt	1471	0	1457	27	0
19	Du	1471	0	1457	27	0
19	Dx	1471	0	1457	25	0
19	Dy	1471	0	1457	28	0
20	D6	58	0	27	8	0
20	D7	43	0	22	12	0
20	D8	48	0	24	13	0
20	D9	48	0	24	7	0
21	EA	84	0	46	6	0
21	EB	84	0	46	3	0
21	EC	84	0	46	4	0
21	ED	84	0	46	1	0
21	EE	84	0	46	2	0
21	EF	84	0	46	4	0
22	2	51	0	78	12	0
22	e	51	0	78	4	0
22	t	51	0	78	17	0
22	v	51	0	78	12	0
23	e	32	0	0	1	0
23	s	32	0	0	1	0
23	t	32	0	0	2	0
23	u	32	0	0	3	0
23	v	32	0	0	6	0
All	All	555596	0	544123	9596	0

The all-atom clashscore is defined as the number of clashes found per 1000 atoms (including hydrogen atoms). The all-atom clashscore for this structure is 9.

The worst 5 of 9596 close contacts within the same asymmetric unit are listed below, sorted by their clash magnitude.

Atom-1	Atom-2	Interatomic distance (Å)	Clash overlap (Å)
3:7:64:LEU:HD11	7:EY:148:PHE:CE1	1.54	1.41
6:Ax:371:THR:HG22	5:S:161:ARG:CZ	1.61	1.30
6:Ay:371:THR:HG22	5:T:161:ARG:NH1	1.41	1.30
3:4:15:TRP:CD1	7:Er:148:PHE:HE2	1.51	1.28
2:y:288:ALA:CB	7:Er:192:PHE:HA	1.63	1.26

There are no symmetry-related clashes.

5.3 Torsion angles [i](#)

5.3.1 Protein backbone [i](#)

In the following table, the Percentiles column shows the percent Ramachandran outliers of the chain as a percentile score with respect to all PDB entries followed by that with respect to all EM entries.

The Analysed column shows the number of residues for which the backbone conformation was analysed, and the total number of residues.

Mol	Chain	Analysed	Favoured	Allowed	Outliers	Percentiles	
1	0	178/199 (89%)	173 (97%)	5 (3%)	0	100	100
1	9	178/199 (89%)	174 (98%)	4 (2%)	0	100	100
2	1	205/289 (71%)	202 (98%)	3 (2%)	0	100	100
2	2	206/289 (71%)	203 (98%)	3 (2%)	0	100	100
2	3	206/289 (71%)	204 (99%)	2 (1%)	0	100	100
2	y	206/289 (71%)	202 (98%)	4 (2%)	0	100	100
2	z	206/289 (71%)	202 (98%)	4 (2%)	0	100	100
3	4	87/89 (98%)	87 (100%)	0	0	100	100
3	5	87/89 (98%)	86 (99%)	0	1 (1%)	12	43
3	6	87/89 (98%)	84 (97%)	3 (3%)	0	100	100
3	7	87/89 (98%)	86 (99%)	1 (1%)	0	100	100
4	8	238/260 (92%)	232 (98%)	6 (2%)	0	100	100

Continued on next page...

Continued from previous page...

Mol	Chain	Analysed	Favoured	Allowed	Outliers	Percentiles	
5	A	260/262 (99%)	251 (96%)	9 (4%)	0	100	100
5	AP	260/262 (99%)	253 (97%)	6 (2%)	1 (0%)	30	63
5	AQ	260/262 (99%)	248 (95%)	11 (4%)	1 (0%)	30	63
5	AR	244/262 (93%)	240 (98%)	3 (1%)	1 (0%)	30	63
5	AS	244/262 (93%)	235 (96%)	9 (4%)	0	100	100
5	AT	245/262 (94%)	239 (98%)	5 (2%)	1 (0%)	30	63
5	AU	244/262 (93%)	240 (98%)	4 (2%)	0	100	100
5	AV	244/262 (93%)	242 (99%)	1 (0%)	1 (0%)	30	63
5	AW	260/262 (99%)	254 (98%)	5 (2%)	1 (0%)	30	63
5	AX	260/262 (99%)	254 (98%)	6 (2%)	0	100	100
5	AY	260/262 (99%)	254 (98%)	6 (2%)	0	100	100
5	AZ	260/262 (99%)	255 (98%)	5 (2%)	0	100	100
5	Aa	260/262 (99%)	249 (96%)	11 (4%)	0	100	100
5	B	260/262 (99%)	250 (96%)	10 (4%)	0	100	100
5	C	260/262 (99%)	252 (97%)	7 (3%)	1 (0%)	30	63
5	P	260/262 (99%)	253 (97%)	6 (2%)	1 (0%)	30	63
5	Q	260/262 (99%)	257 (99%)	3 (1%)	0	100	100
5	R	260/262 (99%)	254 (98%)	6 (2%)	0	100	100
5	S	260/262 (99%)	253 (97%)	7 (3%)	0	100	100
5	T	260/262 (99%)	253 (97%)	7 (3%)	0	100	100
5	U	260/262 (99%)	255 (98%)	5 (2%)	0	100	100
5	V	260/262 (99%)	251 (96%)	9 (4%)	0	100	100
5	W	260/262 (99%)	253 (97%)	6 (2%)	1 (0%)	30	63
5	X	260/262 (99%)	250 (96%)	9 (4%)	1 (0%)	30	63
5	Y	260/262 (99%)	253 (97%)	7 (3%)	0	100	100
5	Z	260/262 (99%)	253 (97%)	7 (3%)	0	100	100
5	a	260/262 (99%)	253 (97%)	7 (3%)	0	100	100
6	A1	433/437 (99%)	419 (97%)	12 (3%)	2 (0%)	25	59
6	A2	433/437 (99%)	418 (96%)	13 (3%)	2 (0%)	25	59
6	A3	433/437 (99%)	419 (97%)	13 (3%)	1 (0%)	44	74
6	Ab	433/437 (99%)	416 (96%)	17 (4%)	0	100	100

Continued on next page...

Continued from previous page...

Mol	Chain	Analysed	Favoured	Allowed	Outliers	Percentiles	
6	Ac	433/437 (99%)	419 (97%)	14 (3%)	0	100	100
6	Ad	433/437 (99%)	418 (96%)	15 (4%)	0	100	100
6	Ae	433/437 (99%)	422 (98%)	11 (2%)	0	100	100
6	Af	433/437 (99%)	417 (96%)	16 (4%)	0	100	100
6	Ag	433/437 (99%)	417 (96%)	16 (4%)	0	100	100
6	Ah	433/437 (99%)	417 (96%)	16 (4%)	0	100	100
6	Ai	433/437 (99%)	420 (97%)	13 (3%)	0	100	100
6	Aj	433/437 (99%)	419 (97%)	14 (3%)	0	100	100
6	Ak	433/437 (99%)	418 (96%)	15 (4%)	0	100	100
6	Al	433/437 (99%)	420 (97%)	13 (3%)	0	100	100
6	Am	433/437 (99%)	418 (96%)	15 (4%)	0	100	100
6	An	433/437 (99%)	419 (97%)	14 (3%)	0	100	100
6	Ao	433/437 (99%)	422 (98%)	11 (2%)	0	100	100
6	Ap	433/437 (99%)	416 (96%)	16 (4%)	1 (0%)	44	74
6	Aq	433/437 (99%)	418 (96%)	13 (3%)	2 (0%)	25	59
6	Ar	433/437 (99%)	417 (96%)	14 (3%)	2 (0%)	25	59
6	As	433/437 (99%)	417 (96%)	14 (3%)	2 (0%)	25	59
6	At	433/437 (99%)	420 (97%)	12 (3%)	1 (0%)	44	74
6	Au	433/437 (99%)	417 (96%)	14 (3%)	2 (0%)	25	59
6	Av	433/437 (99%)	422 (98%)	8 (2%)	3 (1%)	19	53
6	Aw	433/437 (99%)	416 (96%)	15 (4%)	2 (0%)	25	59
6	Ax	433/437 (99%)	419 (97%)	14 (3%)	0	100	100
6	Ay	433/437 (99%)	420 (97%)	12 (3%)	1 (0%)	44	74
6	Az	433/437 (99%)	417 (96%)	15 (4%)	1 (0%)	44	74
6	D	433/437 (99%)	420 (97%)	13 (3%)	0	100	100
6	E	433/437 (99%)	416 (96%)	17 (4%)	0	100	100
6	F	433/437 (99%)	419 (97%)	14 (3%)	0	100	100
6	G	433/437 (99%)	418 (96%)	15 (4%)	0	100	100
6	H	433/437 (99%)	419 (97%)	14 (3%)	0	100	100
6	I	433/437 (99%)	418 (96%)	15 (4%)	0	100	100
6	J	433/437 (99%)	420 (97%)	13 (3%)	0	100	100

Continued on next page...

Continued from previous page...

Mol	Chain	Analysed	Favoured	Allowed	Outliers	Percentiles	
6	K	433/437 (99%)	419 (97%)	14 (3%)	0	100	100
6	L	433/437 (99%)	420 (97%)	13 (3%)	0	100	100
6	M	433/437 (99%)	419 (97%)	14 (3%)	0	100	100
6	N	433/437 (99%)	419 (97%)	14 (3%)	0	100	100
6	O	433/437 (99%)	419 (97%)	14 (3%)	0	100	100
7	AA	17/580 (3%)	17 (100%)	0	0	100	100
7	AB	17/580 (3%)	15 (88%)	2 (12%)	0	100	100
7	AC	18/580 (3%)	18 (100%)	0	0	100	100
7	AD	17/580 (3%)	17 (100%)	0	0	100	100
7	AE	17/580 (3%)	17 (100%)	0	0	100	100
7	AF	21/580 (4%)	14 (67%)	6 (29%)	1 (5%)	2	13
7	AG	9/580 (2%)	7 (78%)	2 (22%)	0	100	100
7	AH	9/580 (2%)	9 (100%)	0	0	100	100
7	AI	9/580 (2%)	8 (89%)	1 (11%)	0	100	100
7	AJ	22/580 (4%)	18 (82%)	4 (18%)	0	100	100
7	AK	23/580 (4%)	23 (100%)	0	0	100	100
7	AL	30/580 (5%)	26 (87%)	4 (13%)	0	100	100
7	AM	31/580 (5%)	31 (100%)	0	0	100	100
7	AN	31/580 (5%)	31 (100%)	0	0	100	100
7	AO	30/580 (5%)	30 (100%)	0	0	100	100
7	D1	142/580 (24%)	138 (97%)	4 (3%)	0	100	100
7	D2	142/580 (24%)	138 (97%)	4 (3%)	0	100	100
7	D3	142/580 (24%)	138 (97%)	4 (3%)	0	100	100
7	D4	142/580 (24%)	138 (97%)	4 (3%)	0	100	100
7	D5	142/580 (24%)	138 (97%)	4 (3%)	0	100	100
7	Dz	142/580 (24%)	138 (97%)	4 (3%)	0	100	100
7	E1	142/580 (24%)	138 (97%)	4 (3%)	0	100	100
7	E2	142/580 (24%)	138 (97%)	4 (3%)	0	100	100
7	E3	142/580 (24%)	138 (97%)	4 (3%)	0	100	100
7	E4	142/580 (24%)	138 (97%)	4 (3%)	0	100	100
7	E5	142/580 (24%)	138 (97%)	4 (3%)	0	100	100

Continued on next page...

Continued from previous page...

Mol	Chain	Analysed	Favoured	Allowed	Outliers	Percentiles	
7	EG	142/580 (24%)	138 (97%)	4 (3%)	0	100	100
7	EH	142/580 (24%)	139 (98%)	3 (2%)	0	100	100
7	EI	142/580 (24%)	138 (97%)	4 (3%)	0	100	100
7	EJ	142/580 (24%)	138 (97%)	4 (3%)	0	100	100
7	EK	142/580 (24%)	138 (97%)	4 (3%)	0	100	100
7	EL	142/580 (24%)	138 (97%)	4 (3%)	0	100	100
7	EM	142/580 (24%)	138 (97%)	4 (3%)	0	100	100
7	EN	142/580 (24%)	138 (97%)	4 (3%)	0	100	100
7	EO	142/580 (24%)	138 (97%)	4 (3%)	0	100	100
7	EP	142/580 (24%)	138 (97%)	4 (3%)	0	100	100
7	EQ	142/580 (24%)	138 (97%)	4 (3%)	0	100	100
7	ER	142/580 (24%)	138 (97%)	4 (3%)	0	100	100
7	ES	142/580 (24%)	138 (97%)	4 (3%)	0	100	100
7	ET	142/580 (24%)	139 (98%)	3 (2%)	0	100	100
7	EU	142/580 (24%)	138 (97%)	4 (3%)	0	100	100
7	EV	142/580 (24%)	138 (97%)	4 (3%)	0	100	100
7	EW	142/580 (24%)	138 (97%)	4 (3%)	0	100	100
7	EX	112/580 (19%)	100 (89%)	10 (9%)	2 (2%)	7	34
7	EY	112/580 (19%)	99 (88%)	12 (11%)	1 (1%)	14	48
7	EZ	112/580 (19%)	101 (90%)	11 (10%)	0	100	100
7	Ea	112/580 (19%)	102 (91%)	9 (8%)	1 (1%)	14	48
7	Eb	112/580 (19%)	104 (93%)	7 (6%)	1 (1%)	14	48
7	Ec	105/580 (18%)	97 (92%)	7 (7%)	1 (1%)	13	45
7	Ed	112/580 (19%)	99 (88%)	11 (10%)	2 (2%)	7	34
7	Ee	112/580 (19%)	99 (88%)	12 (11%)	1 (1%)	14	48
7	Ef	112/580 (19%)	102 (91%)	9 (8%)	1 (1%)	14	48
7	Eg	90/580 (16%)	83 (92%)	6 (7%)	1 (1%)	12	43
7	EH	101/580 (17%)	93 (92%)	7 (7%)	1 (1%)	13	45
7	Ei	101/580 (17%)	93 (92%)	8 (8%)	0	100	100
7	Ej	101/580 (17%)	90 (89%)	10 (10%)	1 (1%)	13	45
7	Ek	81/580 (14%)	74 (91%)	7 (9%)	0	100	100

Continued on next page...

Continued from previous page...

Mol	Chain	Analysed	Favoured	Allowed	Outliers	Percentiles	
7	El	88/580 (15%)	83 (94%)	5 (6%)	0	100	100
7	Em	87/580 (15%)	82 (94%)	5 (6%)	0	100	100
7	En	85/580 (15%)	81 (95%)	4 (5%)	0	100	100
7	Eo	88/580 (15%)	80 (91%)	8 (9%)	0	100	100
7	Ep	112/580 (19%)	106 (95%)	5 (4%)	1 (1%)	14	48
7	Eq	112/580 (19%)	98 (88%)	13 (12%)	1 (1%)	14	48
7	Er	112/580 (19%)	103 (92%)	8 (7%)	1 (1%)	14	48
7	Es	101/580 (17%)	95 (94%)	4 (4%)	2 (2%)	6	31
7	Et	112/580 (19%)	104 (93%)	6 (5%)	2 (2%)	7	34
7	Eu	142/580 (24%)	138 (97%)	4 (3%)	0	100	100
7	Ev	142/580 (24%)	138 (97%)	4 (3%)	0	100	100
7	Ew	142/580 (24%)	138 (97%)	4 (3%)	0	100	100
7	Ex	142/580 (24%)	138 (97%)	4 (3%)	0	100	100
7	Ey	142/580 (24%)	138 (97%)	4 (3%)	0	100	100
7	Ez	142/580 (24%)	139 (98%)	3 (2%)	0	100	100
8	b	105/131 (80%)	104 (99%)	1 (1%)	0	100	100
8	c	103/131 (79%)	102 (99%)	1 (1%)	0	100	100
8	d	105/131 (80%)	103 (98%)	2 (2%)	0	100	100
8	e	104/131 (79%)	104 (100%)	0	0	100	100
8	f	104/131 (79%)	103 (99%)	1 (1%)	0	100	100
9	g	126/137 (92%)	122 (97%)	4 (3%)	0	100	100
9	h	126/137 (92%)	123 (98%)	3 (2%)	0	100	100
9	i	126/137 (92%)	122 (97%)	3 (2%)	1 (1%)	16	50
9	j	126/137 (92%)	125 (99%)	1 (1%)	0	100	100
9	k	126/137 (92%)	120 (95%)	6 (5%)	0	100	100
9	l	126/137 (92%)	121 (96%)	5 (4%)	0	100	100
10	m	246/249 (99%)	242 (98%)	4 (2%)	0	100	100
10	n	246/249 (99%)	242 (98%)	4 (2%)	0	100	100
10	o	246/249 (99%)	241 (98%)	5 (2%)	0	100	100
10	p	246/249 (99%)	242 (98%)	4 (2%)	0	100	100
10	q	246/249 (99%)	240 (98%)	6 (2%)	0	100	100

Continued on next page...

Continued from previous page...

Mol	Chain	Analysed	Favoured	Allowed	Outliers	Percentiles	
11	r	70/103 (68%)	70 (100%)	0	0	100	100
11	s	78/103 (76%)	78 (100%)	0	0	100	100
11	t	78/103 (76%)	77 (99%)	1 (1%)	0	100	100
11	u	70/103 (68%)	69 (99%)	1 (1%)	0	100	100
11	v	70/103 (68%)	69 (99%)	1 (1%)	0	100	100
11	w	38/103 (37%)	38 (100%)	0	0	100	100
12	x	69/376 (18%)	69 (100%)	0	0	100	100
13	A8	350/377 (93%)	346 (99%)	4 (1%)	0	100	100
13	B1	350/377 (93%)	346 (99%)	4 (1%)	0	100	100
13	B6	350/377 (93%)	346 (99%)	4 (1%)	0	100	100
13	B7	350/377 (93%)	346 (99%)	4 (1%)	0	100	100
13	BC	350/377 (93%)	346 (99%)	4 (1%)	0	100	100
13	BH	350/377 (93%)	346 (99%)	4 (1%)	0	100	100
13	BM	350/377 (93%)	346 (99%)	4 (1%)	0	100	100
13	BR	350/377 (93%)	346 (99%)	4 (1%)	0	100	100
13	BW	350/377 (93%)	346 (99%)	4 (1%)	0	100	100
13	Bb	350/377 (93%)	346 (99%)	4 (1%)	0	100	100
13	Bg	350/377 (93%)	346 (99%)	4 (1%)	0	100	100
13	Bl	350/377 (93%)	346 (99%)	4 (1%)	0	100	100
13	Bq	350/377 (93%)	346 (99%)	4 (1%)	0	100	100
13	Bv	350/377 (93%)	346 (99%)	4 (1%)	0	100	100
13	C3	350/377 (93%)	346 (99%)	4 (1%)	0	100	100
13	C8	350/377 (93%)	346 (99%)	4 (1%)	0	100	100
13	CB	350/377 (93%)	346 (99%)	4 (1%)	0	100	100
13	CJ	350/377 (93%)	346 (99%)	4 (1%)	0	100	100
13	CO	350/377 (93%)	346 (99%)	4 (1%)	0	100	100
13	CT	350/377 (93%)	346 (99%)	4 (1%)	0	100	100
13	CY	350/377 (93%)	346 (99%)	4 (1%)	0	100	100
13	Cd	350/377 (93%)	346 (99%)	4 (1%)	0	100	100
13	Ci	350/377 (93%)	346 (99%)	4 (1%)	0	100	100
13	Cn	350/377 (93%)	346 (99%)	4 (1%)	0	100	100

Continued on next page...

Continued from previous page...

Mol	Chain	Analysed	Favoured	Allowed	Outliers	Percentiles	
13	Cs	350/377 (93%)	346 (99%)	4 (1%)	0	100	100
13	Cx	350/377 (93%)	346 (99%)	4 (1%)	0	100	100
14	A4	217/259 (84%)	212 (98%)	4 (2%)	1 (0%)	25	59
14	A9	217/259 (84%)	212 (98%)	4 (2%)	1 (0%)	25	59
14	B2	217/259 (84%)	212 (98%)	4 (2%)	1 (0%)	25	59
14	B8	217/259 (84%)	212 (98%)	4 (2%)	1 (0%)	25	59
14	BD	217/259 (84%)	212 (98%)	4 (2%)	1 (0%)	25	59
14	BI	217/259 (84%)	212 (98%)	4 (2%)	1 (0%)	25	59
14	BN	217/259 (84%)	212 (98%)	4 (2%)	1 (0%)	25	59
14	BS	217/259 (84%)	212 (98%)	4 (2%)	1 (0%)	25	59
14	BX	217/259 (84%)	212 (98%)	4 (2%)	1 (0%)	25	59
14	Bc	217/259 (84%)	212 (98%)	4 (2%)	1 (0%)	25	59
14	Bh	217/259 (84%)	212 (98%)	4 (2%)	1 (0%)	25	59
14	Bm	217/259 (84%)	212 (98%)	4 (2%)	1 (0%)	25	59
14	Br	217/259 (84%)	212 (98%)	4 (2%)	1 (0%)	25	59
14	Bw	217/259 (84%)	212 (98%)	4 (2%)	1 (0%)	25	59
14	C4	217/259 (84%)	212 (98%)	4 (2%)	1 (0%)	25	59
14	C9	217/259 (84%)	212 (98%)	4 (2%)	1 (0%)	25	59
14	CC	217/259 (84%)	211 (97%)	5 (2%)	1 (0%)	25	59
14	CK	217/259 (84%)	212 (98%)	4 (2%)	1 (0%)	25	59
14	CP	217/259 (84%)	212 (98%)	4 (2%)	1 (0%)	25	59
14	CU	217/259 (84%)	212 (98%)	4 (2%)	1 (0%)	25	59
14	CZ	217/259 (84%)	212 (98%)	4 (2%)	1 (0%)	25	59
14	Ce	217/259 (84%)	212 (98%)	4 (2%)	1 (0%)	25	59
14	Cj	217/259 (84%)	212 (98%)	4 (2%)	1 (0%)	25	59
14	Co	217/259 (84%)	211 (97%)	5 (2%)	1 (0%)	25	59
14	Ct	217/259 (84%)	211 (97%)	5 (2%)	1 (0%)	25	59
14	Cy	217/259 (84%)	212 (98%)	4 (2%)	1 (0%)	25	59
15	A0	9/143 (6%)	9 (100%)	0	0	100	100
15	A5	9/143 (6%)	9 (100%)	0	0	100	100
15	B3	9/143 (6%)	9 (100%)	0	0	100	100

Continued on next page...

Continued from previous page...

Mol	Chain	Analysed	Favoured	Allowed	Outliers	Percentiles	
15	B9	9/143 (6%)	9 (100%)	0	0	100	100
15	BE	9/143 (6%)	9 (100%)	0	0	100	100
15	BJ	9/143 (6%)	9 (100%)	0	0	100	100
15	BO	9/143 (6%)	9 (100%)	0	0	100	100
15	BT	9/143 (6%)	9 (100%)	0	0	100	100
15	BY	9/143 (6%)	9 (100%)	0	0	100	100
15	Bd	9/143 (6%)	9 (100%)	0	0	100	100
15	Bi	9/143 (6%)	9 (100%)	0	0	100	100
15	Bn	9/143 (6%)	9 (100%)	0	0	100	100
15	Bs	9/143 (6%)	9 (100%)	0	0	100	100
15	Bx	9/143 (6%)	9 (100%)	0	0	100	100
15	C0	9/143 (6%)	9 (100%)	0	0	100	100
15	C5	9/143 (6%)	9 (100%)	0	0	100	100
15	CD	9/143 (6%)	9 (100%)	0	0	100	100
15	CL	9/143 (6%)	9 (100%)	0	0	100	100
15	CQ	9/143 (6%)	9 (100%)	0	0	100	100
15	CV	9/143 (6%)	9 (100%)	0	0	100	100
15	Ca	9/143 (6%)	9 (100%)	0	0	100	100
15	Cf	9/143 (6%)	9 (100%)	0	0	100	100
15	Ck	9/143 (6%)	9 (100%)	0	0	100	100
15	Cp	9/143 (6%)	9 (100%)	0	0	100	100
15	Cu	9/143 (6%)	9 (100%)	0	0	100	100
15	Cz	9/143 (6%)	9 (100%)	0	0	100	100
16	A6	11/13 (85%)	9 (82%)	2 (18%)	0	100	100
16	B0	11/13 (85%)	9 (82%)	2 (18%)	0	100	100
16	B4	11/13 (85%)	9 (82%)	2 (18%)	0	100	100
16	BA	11/13 (85%)	9 (82%)	2 (18%)	0	100	100
16	BF	11/13 (85%)	9 (82%)	2 (18%)	0	100	100
16	BK	11/13 (85%)	9 (82%)	2 (18%)	0	100	100
16	BP	11/13 (85%)	9 (82%)	2 (18%)	0	100	100
16	BU	11/13 (85%)	9 (82%)	2 (18%)	0	100	100

Continued on next page...

Continued from previous page...

Mol	Chain	Analysed	Favoured	Allowed	Outliers	Percentiles	
16	BZ	11/13 (85%)	9 (82%)	2 (18%)	0	100	100
16	Be	11/13 (85%)	9 (82%)	2 (18%)	0	100	100
16	Bj	11/13 (85%)	9 (82%)	2 (18%)	0	100	100
16	Bo	11/13 (85%)	9 (82%)	2 (18%)	0	100	100
16	Bt	11/13 (85%)	9 (82%)	2 (18%)	0	100	100
16	By	11/13 (85%)	9 (82%)	2 (18%)	0	100	100
16	C1	11/13 (85%)	9 (82%)	2 (18%)	0	100	100
16	C6	11/13 (85%)	9 (82%)	2 (18%)	0	100	100
16	CE	11/13 (85%)	9 (82%)	2 (18%)	0	100	100
16	CH	11/13 (85%)	9 (82%)	2 (18%)	0	100	100
16	CM	11/13 (85%)	9 (82%)	2 (18%)	0	100	100
16	CR	11/13 (85%)	9 (82%)	2 (18%)	0	100	100
16	CW	11/13 (85%)	9 (82%)	2 (18%)	0	100	100
16	Cb	11/13 (85%)	9 (82%)	2 (18%)	0	100	100
16	Cg	11/13 (85%)	9 (82%)	2 (18%)	0	100	100
16	Cl	11/13 (85%)	9 (82%)	2 (18%)	0	100	100
16	Cq	11/13 (85%)	9 (82%)	2 (18%)	0	100	100
16	Cv	11/13 (85%)	9 (82%)	2 (18%)	0	100	100
16	D0	11/13 (85%)	6 (54%)	4 (36%)	1 (9%)	0	3
17	A7	281/363 (77%)	275 (98%)	6 (2%)	0	100	100
17	B5	281/363 (77%)	275 (98%)	6 (2%)	0	100	100
17	BB	281/363 (77%)	275 (98%)	6 (2%)	0	100	100
17	BG	281/363 (77%)	275 (98%)	6 (2%)	0	100	100
17	BL	281/363 (77%)	275 (98%)	6 (2%)	0	100	100
17	BQ	281/363 (77%)	275 (98%)	6 (2%)	0	100	100
17	BV	281/363 (77%)	275 (98%)	6 (2%)	0	100	100
17	Ba	281/363 (77%)	275 (98%)	6 (2%)	0	100	100
17	Bf	281/363 (77%)	275 (98%)	6 (2%)	0	100	100
17	Bk	281/363 (77%)	275 (98%)	6 (2%)	0	100	100
17	Bp	281/363 (77%)	275 (98%)	6 (2%)	0	100	100
17	Bu	281/363 (77%)	275 (98%)	6 (2%)	0	100	100

Continued on next page...

Continued from previous page...

Mol	Chain	Analysed	Favoured	Allowed	Outliers	Percentiles	
17	Bz	281/363 (77%)	275 (98%)	6 (2%)	0	100	100
17	C2	281/363 (77%)	275 (98%)	6 (2%)	0	100	100
17	C7	281/363 (77%)	275 (98%)	6 (2%)	0	100	100
17	CA	281/363 (77%)	275 (98%)	6 (2%)	0	100	100
17	CF	281/363 (77%)	275 (98%)	6 (2%)	0	100	100
17	CI	281/363 (77%)	275 (98%)	6 (2%)	0	100	100
17	CN	281/363 (77%)	275 (98%)	6 (2%)	0	100	100
17	CS	281/363 (77%)	275 (98%)	6 (2%)	0	100	100
17	CX	281/363 (77%)	275 (98%)	6 (2%)	0	100	100
17	Cc	281/363 (77%)	275 (98%)	6 (2%)	0	100	100
17	Ch	281/363 (77%)	275 (98%)	6 (2%)	0	100	100
17	Cm	281/363 (77%)	275 (98%)	6 (2%)	0	100	100
17	Cr	281/363 (77%)	275 (98%)	6 (2%)	0	100	100
17	Cw	281/363 (77%)	275 (98%)	6 (2%)	0	100	100
18	CG	268/293 (92%)	259 (97%)	9 (3%)	0	100	100
18	DA	269/293 (92%)	267 (99%)	2 (1%)	0	100	100
18	DD	268/293 (92%)	259 (97%)	9 (3%)	0	100	100
18	DE	269/293 (92%)	267 (99%)	2 (1%)	0	100	100
18	DH	268/293 (92%)	259 (97%)	9 (3%)	0	100	100
18	DI	269/293 (92%)	267 (99%)	2 (1%)	0	100	100
18	DL	268/293 (92%)	259 (97%)	9 (3%)	0	100	100
18	DM	269/293 (92%)	267 (99%)	2 (1%)	0	100	100
18	DP	268/293 (92%)	259 (97%)	9 (3%)	0	100	100
18	DQ	269/293 (92%)	266 (99%)	3 (1%)	0	100	100
18	DT	268/293 (92%)	259 (97%)	9 (3%)	0	100	100
18	DU	269/293 (92%)	267 (99%)	2 (1%)	0	100	100
18	DX	268/293 (92%)	259 (97%)	9 (3%)	0	100	100
18	DY	269/293 (92%)	267 (99%)	2 (1%)	0	100	100
18	Db	268/293 (92%)	259 (97%)	9 (3%)	0	100	100
18	Dc	269/293 (92%)	266 (99%)	3 (1%)	0	100	100
18	Df	268/293 (92%)	259 (97%)	9 (3%)	0	100	100

Continued on next page...

Continued from previous page...

Mol	Chain	Analysed	Favoured	Allowed	Outliers	Percentiles	
18	Dg	269/293 (92%)	267 (99%)	2 (1%)	0	100	100
18	Dj	268/293 (92%)	259 (97%)	9 (3%)	0	100	100
18	Dk	269/293 (92%)	267 (99%)	2 (1%)	0	100	100
18	Dn	268/293 (92%)	259 (97%)	9 (3%)	0	100	100
18	Do	269/293 (92%)	266 (99%)	3 (1%)	0	100	100
18	Dr	268/293 (92%)	259 (97%)	9 (3%)	0	100	100
18	Ds	269/293 (92%)	267 (99%)	2 (1%)	0	100	100
18	Dv	268/293 (92%)	259 (97%)	9 (3%)	0	100	100
18	Dw	269/293 (92%)	267 (99%)	2 (1%)	0	100	100
19	DB	177/211 (84%)	170 (96%)	6 (3%)	1 (1%)	22	56
19	DC	177/211 (84%)	172 (97%)	5 (3%)	0	100	100
19	DF	177/211 (84%)	170 (96%)	6 (3%)	1 (1%)	22	56
19	DG	177/211 (84%)	172 (97%)	5 (3%)	0	100	100
19	DJ	177/211 (84%)	170 (96%)	6 (3%)	1 (1%)	22	56
19	DK	177/211 (84%)	172 (97%)	5 (3%)	0	100	100
19	DN	177/211 (84%)	170 (96%)	6 (3%)	1 (1%)	22	56
19	DO	177/211 (84%)	172 (97%)	5 (3%)	0	100	100
19	DR	177/211 (84%)	170 (96%)	6 (3%)	1 (1%)	22	56
19	DS	177/211 (84%)	172 (97%)	5 (3%)	0	100	100
19	DV	177/211 (84%)	170 (96%)	6 (3%)	1 (1%)	22	56
19	DW	177/211 (84%)	172 (97%)	5 (3%)	0	100	100
19	DZ	177/211 (84%)	170 (96%)	6 (3%)	1 (1%)	22	56
19	Da	177/211 (84%)	172 (97%)	5 (3%)	0	100	100
19	Dd	177/211 (84%)	170 (96%)	6 (3%)	1 (1%)	22	56
19	De	177/211 (84%)	172 (97%)	5 (3%)	0	100	100
19	Dh	177/211 (84%)	170 (96%)	6 (3%)	1 (1%)	22	56
19	Di	177/211 (84%)	172 (97%)	5 (3%)	0	100	100
19	DI	177/211 (84%)	170 (96%)	6 (3%)	1 (1%)	22	56
19	Dm	177/211 (84%)	172 (97%)	5 (3%)	0	100	100
19	Dp	177/211 (84%)	170 (96%)	6 (3%)	1 (1%)	22	56
19	Dq	177/211 (84%)	172 (97%)	5 (3%)	0	100	100

Continued on next page...

Continued from previous page...

Mol	Chain	Analysed	Favoured	Allowed	Outliers	Percentiles	
19	Dt	177/211 (84%)	170 (96%)	6 (3%)	1 (1%)	22	56
19	Du	177/211 (84%)	172 (97%)	5 (3%)	0	100	100
19	Dx	177/211 (84%)	170 (96%)	6 (3%)	1 (1%)	22	56
19	Dy	177/211 (84%)	172 (97%)	5 (3%)	0	100	100
20	D6	10/13 (77%)	4 (40%)	5 (50%)	1 (10%)	0	2
20	D7	7/13 (54%)	3 (43%)	4 (57%)	0	100	100
20	D8	8/13 (62%)	8 (100%)	0	0	100	100
20	D9	8/13 (62%)	3 (38%)	3 (38%)	2 (25%)	0	0
21	EA	15/17 (88%)	15 (100%)	0	0	100	100
21	EB	15/17 (88%)	15 (100%)	0	0	100	100
21	EC	15/17 (88%)	15 (100%)	0	0	100	100
21	ED	15/17 (88%)	15 (100%)	0	0	100	100
21	EE	15/17 (88%)	15 (100%)	0	0	100	100
21	EF	15/17 (88%)	15 (100%)	0	0	100	100
All	All	70998/115790 (61%)	69020 (97%)	1880 (3%)	98 (0%)	50	79

5 of 98 Ramachandran outliers are listed below:

Mol	Chain	Res	Type
6	A1	50	ALA
6	A2	50	ALA
6	Aq	50	ALA
6	Ar	49	ASN
6	Ar	50	ALA

5.3.2 Protein sidechains [i](#)

In the following table, the Percentiles column shows the percent sidechain outliers of the chain as a percentile score with respect to all PDB entries followed by that with respect to all EM entries.

The Analysed column shows the number of residues for which the sidechain conformation was analysed, and the total number of residues.

Mol	Chain	Analysed	Rotameric	Outliers	Percentiles	
1	0	149/167 (89%)	145 (97%)	4 (3%)	40	67
1	9	149/167 (89%)	148 (99%)	1 (1%)	81	90

Continued on next page...

Continued from previous page...

Mol	Chain	Analysed	Rotameric	Outliers	Percentiles	
2	1	181/247 (73%)	175 (97%)	6 (3%)	33	62
2	2	182/247 (74%)	176 (97%)	6 (3%)	33	62
2	3	182/247 (74%)	177 (97%)	5 (3%)	40	67
2	y	182/247 (74%)	175 (96%)	7 (4%)	28	59
2	z	182/247 (74%)	175 (96%)	7 (4%)	28	59
3	4	80/80 (100%)	77 (96%)	3 (4%)	28	59
3	5	80/80 (100%)	77 (96%)	3 (4%)	28	59
3	6	80/80 (100%)	75 (94%)	5 (6%)	15	45
3	7	80/80 (100%)	79 (99%)	1 (1%)	65	81
4	8	204/218 (94%)	194 (95%)	10 (5%)	21	53
5	A	218/218 (100%)	214 (98%)	4 (2%)	54	75
5	AP	218/218 (100%)	214 (98%)	4 (2%)	54	75
5	AQ	218/218 (100%)	211 (97%)	7 (3%)	34	63
5	AR	206/218 (94%)	200 (97%)	6 (3%)	37	65
5	AS	206/218 (94%)	200 (97%)	6 (3%)	37	65
5	AT	207/218 (95%)	200 (97%)	7 (3%)	32	61
5	AU	206/218 (94%)	202 (98%)	4 (2%)	52	74
5	AV	206/218 (94%)	199 (97%)	7 (3%)	32	61
5	AW	218/218 (100%)	213 (98%)	5 (2%)	45	70
5	AX	218/218 (100%)	212 (97%)	6 (3%)	38	66
5	AY	218/218 (100%)	213 (98%)	5 (2%)	45	70
5	AZ	218/218 (100%)	213 (98%)	5 (2%)	45	70
5	Aa	218/218 (100%)	215 (99%)	3 (1%)	62	80
5	B	218/218 (100%)	213 (98%)	5 (2%)	45	70
5	C	218/218 (100%)	211 (97%)	7 (3%)	34	63
5	P	218/218 (100%)	211 (97%)	7 (3%)	34	63
5	Q	218/218 (100%)	212 (97%)	6 (3%)	38	66
5	R	218/218 (100%)	213 (98%)	5 (2%)	45	70
5	S	218/218 (100%)	213 (98%)	5 (2%)	45	70
5	T	218/218 (100%)	212 (97%)	6 (3%)	38	66
5	U	218/218 (100%)	212 (97%)	6 (3%)	38	66

Continued on next page...

Continued from previous page...

Mol	Chain	Analysed	Rotameric	Outliers	Percentiles	
5	V	218/218 (100%)	212 (97%)	6 (3%)	38	66
5	W	218/218 (100%)	212 (97%)	6 (3%)	38	66
5	X	218/218 (100%)	215 (99%)	3 (1%)	62	80
5	Y	218/218 (100%)	211 (97%)	7 (3%)	34	63
5	Z	218/218 (100%)	212 (97%)	6 (3%)	38	66
5	a	218/218 (100%)	211 (97%)	7 (3%)	34	63
6	A1	364/366 (100%)	354 (97%)	10 (3%)	40	67
6	A2	364/366 (100%)	356 (98%)	8 (2%)	47	71
6	A3	364/366 (100%)	352 (97%)	12 (3%)	33	62
6	Ab	364/366 (100%)	349 (96%)	15 (4%)	26	57
6	Ac	364/366 (100%)	347 (95%)	17 (5%)	22	53
6	Ad	364/366 (100%)	345 (95%)	19 (5%)	19	50
6	Ae	364/366 (100%)	348 (96%)	16 (4%)	24	55
6	Af	364/366 (100%)	349 (96%)	15 (4%)	26	57
6	Ag	364/366 (100%)	349 (96%)	15 (4%)	26	57
6	Ah	364/366 (100%)	346 (95%)	18 (5%)	21	53
6	Ai	364/366 (100%)	349 (96%)	15 (4%)	26	57
6	Aj	364/366 (100%)	349 (96%)	15 (4%)	26	57
6	Ak	364/366 (100%)	348 (96%)	16 (4%)	24	55
6	Al	364/366 (100%)	349 (96%)	15 (4%)	26	57
6	Am	364/366 (100%)	348 (96%)	16 (4%)	24	55
6	An	364/366 (100%)	351 (96%)	13 (4%)	30	60
6	Ao	364/366 (100%)	349 (96%)	15 (4%)	26	57
6	Ap	364/366 (100%)	345 (95%)	19 (5%)	19	50
6	Aq	364/366 (100%)	345 (95%)	19 (5%)	19	50
6	Ar	364/366 (100%)	345 (95%)	19 (5%)	19	50
6	As	364/366 (100%)	347 (95%)	17 (5%)	22	53
6	At	364/366 (100%)	346 (95%)	18 (5%)	21	53
6	Au	364/366 (100%)	346 (95%)	18 (5%)	21	53
6	Av	364/366 (100%)	342 (94%)	22 (6%)	16	46
6	Aw	364/366 (100%)	346 (95%)	18 (5%)	21	53

Continued on next page...

Continued from previous page...

Mol	Chain	Analysed	Rotameric	Outliers	Percentiles	
6	Ax	364/366 (100%)	347 (95%)	17 (5%)	22	53
6	Ay	364/366 (100%)	349 (96%)	15 (4%)	26	57
6	Az	364/366 (100%)	353 (97%)	11 (3%)	36	64
6	D	364/366 (100%)	348 (96%)	16 (4%)	24	55
6	E	364/366 (100%)	348 (96%)	16 (4%)	24	55
6	F	364/366 (100%)	350 (96%)	14 (4%)	28	59
6	G	364/366 (100%)	348 (96%)	16 (4%)	24	55
6	H	364/366 (100%)	350 (96%)	14 (4%)	28	59
6	I	364/366 (100%)	347 (95%)	17 (5%)	22	53
6	J	364/366 (100%)	348 (96%)	16 (4%)	24	55
6	K	364/366 (100%)	342 (94%)	22 (6%)	16	46
6	L	364/366 (100%)	343 (94%)	21 (6%)	17	47
6	M	364/366 (100%)	342 (94%)	22 (6%)	16	46
6	N	364/366 (100%)	346 (95%)	18 (5%)	21	53
6	O	364/366 (100%)	349 (96%)	15 (4%)	26	57
7	AA	15/500 (3%)	14 (93%)	1 (7%)	13	42
7	AB	15/500 (3%)	14 (93%)	1 (7%)	13	42
7	AC	15/500 (3%)	15 (100%)	0	100	100
7	AD	15/500 (3%)	14 (93%)	1 (7%)	13	42
7	AE	15/500 (3%)	15 (100%)	0	100	100
7	AF	17/500 (3%)	13 (76%)	4 (24%)	0	3
7	AG	8/500 (2%)	8 (100%)	0	100	100
7	AH	8/500 (2%)	7 (88%)	1 (12%)	3	17
7	AI	8/500 (2%)	8 (100%)	0	100	100
7	AJ	17/500 (3%)	16 (94%)	1 (6%)	16	47
7	AK	18/500 (4%)	15 (83%)	3 (17%)	2	8
7	AL	24/500 (5%)	23 (96%)	1 (4%)	25	56
7	AM	24/500 (5%)	24 (100%)	0	100	100
7	AN	24/500 (5%)	22 (92%)	2 (8%)	9	34
7	AO	24/500 (5%)	23 (96%)	1 (4%)	25	56
7	D1	128/500 (26%)	123 (96%)	5 (4%)	27	58

Continued on next page...

Continued from previous page...

Mol	Chain	Analysed	Rotameric	Outliers	Percentiles	
7	D2	128/500 (26%)	123 (96%)	5 (4%)	27	58
7	D3	128/500 (26%)	123 (96%)	5 (4%)	27	58
7	D4	128/500 (26%)	123 (96%)	5 (4%)	27	58
7	D5	128/500 (26%)	123 (96%)	5 (4%)	27	58
7	Dz	128/500 (26%)	123 (96%)	5 (4%)	27	58
7	E1	128/500 (26%)	123 (96%)	5 (4%)	27	58
7	E2	128/500 (26%)	123 (96%)	5 (4%)	27	58
7	E3	128/500 (26%)	123 (96%)	5 (4%)	27	58
7	E4	128/500 (26%)	123 (96%)	5 (4%)	27	58
7	E5	128/500 (26%)	123 (96%)	5 (4%)	27	58
7	EG	128/500 (26%)	123 (96%)	5 (4%)	27	58
7	EH	128/500 (26%)	123 (96%)	5 (4%)	27	58
7	EI	128/500 (26%)	123 (96%)	5 (4%)	27	58
7	EJ	128/500 (26%)	123 (96%)	5 (4%)	27	58
7	EK	128/500 (26%)	123 (96%)	5 (4%)	27	58
7	EL	128/500 (26%)	123 (96%)	5 (4%)	27	58
7	EM	128/500 (26%)	123 (96%)	5 (4%)	27	58
7	EN	128/500 (26%)	123 (96%)	5 (4%)	27	58
7	EO	128/500 (26%)	123 (96%)	5 (4%)	27	58
7	EP	128/500 (26%)	123 (96%)	5 (4%)	27	58
7	EQ	128/500 (26%)	123 (96%)	5 (4%)	27	58
7	ER	128/500 (26%)	123 (96%)	5 (4%)	27	58
7	ES	128/500 (26%)	123 (96%)	5 (4%)	27	58
7	ET	128/500 (26%)	123 (96%)	5 (4%)	27	58
7	EU	128/500 (26%)	123 (96%)	5 (4%)	27	58
7	EV	128/500 (26%)	123 (96%)	5 (4%)	27	58
7	EW	128/500 (26%)	123 (96%)	5 (4%)	27	58
7	EX	98/500 (20%)	86 (88%)	12 (12%)	4	18
7	EY	98/500 (20%)	84 (86%)	14 (14%)	2	12
7	EZ	98/500 (20%)	89 (91%)	9 (9%)	7	28
7	Ea	98/500 (20%)	88 (90%)	10 (10%)	6	25

Continued on next page...

Continued from previous page...

Mol	Chain	Analysed	Rotameric	Outliers	Percentiles	
7	Eb	98/500 (20%)	86 (88%)	12 (12%)	4	18
7	Ec	93/500 (19%)	85 (91%)	8 (9%)	8	32
7	Ed	98/500 (20%)	89 (91%)	9 (9%)	7	28
7	Ee	98/500 (20%)	89 (91%)	9 (9%)	7	28
7	Ef	98/500 (20%)	93 (95%)	5 (5%)	20	51
7	Eg	81/500 (16%)	78 (96%)	3 (4%)	29	60
7	Eh	90/500 (18%)	84 (93%)	6 (7%)	13	42
7	Ei	90/500 (18%)	81 (90%)	9 (10%)	6	25
7	Ej	90/500 (18%)	78 (87%)	12 (13%)	3	15
7	Ek	75/500 (15%)	71 (95%)	4 (5%)	19	50
7	El	79/500 (16%)	72 (91%)	7 (9%)	8	30
7	Em	78/500 (16%)	73 (94%)	5 (6%)	14	44
7	En	77/500 (15%)	72 (94%)	5 (6%)	14	44
7	Eo	79/500 (16%)	73 (92%)	6 (8%)	11	38
7	Ep	98/500 (20%)	88 (90%)	10 (10%)	6	25
7	Eq	98/500 (20%)	88 (90%)	10 (10%)	6	25
7	Er	98/500 (20%)	91 (93%)	7 (7%)	12	40
7	Es	89/500 (18%)	83 (93%)	6 (7%)	13	42
7	Et	98/500 (20%)	93 (95%)	5 (5%)	20	51
7	Eu	128/500 (26%)	123 (96%)	5 (4%)	27	58
7	Ev	128/500 (26%)	123 (96%)	5 (4%)	27	58
7	Ew	128/500 (26%)	123 (96%)	5 (4%)	27	58
7	Ex	128/500 (26%)	123 (96%)	5 (4%)	27	58
7	Ey	128/500 (26%)	123 (96%)	5 (4%)	27	58
7	Ez	128/500 (26%)	123 (96%)	5 (4%)	27	58
8	b	89/106 (84%)	88 (99%)	1 (1%)	70	84
8	c	88/106 (83%)	86 (98%)	2 (2%)	45	70
8	d	89/106 (84%)	86 (97%)	3 (3%)	32	61
8	e	88/106 (83%)	85 (97%)	3 (3%)	32	61
8	f	88/106 (83%)	88 (100%)	0	100	100
9	g	111/115 (96%)	106 (96%)	5 (4%)	23	54

Continued on next page...

Continued from previous page...

Mol	Chain	Analysed	Rotameric	Outliers	Percentiles	
9	h	111/115 (96%)	107 (96%)	4 (4%)	30	60
9	i	111/115 (96%)	103 (93%)	8 (7%)	12	40
9	j	111/115 (96%)	106 (96%)	5 (4%)	23	54
9	k	111/115 (96%)	105 (95%)	6 (5%)	18	50
9	l	111/115 (96%)	106 (96%)	5 (4%)	23	54
10	m	204/205 (100%)	199 (98%)	5 (2%)	42	69
10	n	204/205 (100%)	198 (97%)	6 (3%)	37	65
10	o	204/205 (100%)	198 (97%)	6 (3%)	37	65
10	p	204/205 (100%)	202 (99%)	2 (1%)	73	86
10	q	204/205 (100%)	200 (98%)	4 (2%)	50	73
11	r	63/84 (75%)	59 (94%)	4 (6%)	15	45
11	s	66/84 (79%)	64 (97%)	2 (3%)	36	64
11	t	66/84 (79%)	63 (96%)	3 (4%)	23	54
11	u	63/84 (75%)	62 (98%)	1 (2%)	58	78
11	v	63/84 (75%)	63 (100%)	0	100	100
11	w	36/84 (43%)	35 (97%)	1 (3%)	38	66
12	x	58/317 (18%)	55 (95%)	3 (5%)	19	50
13	A8	308/332 (93%)	303 (98%)	5 (2%)	58	78
13	B1	308/332 (93%)	306 (99%)	2 (1%)	84	91
13	B6	308/332 (93%)	303 (98%)	5 (2%)	58	78
13	B7	308/332 (93%)	303 (98%)	5 (2%)	58	78
13	BC	308/332 (93%)	303 (98%)	5 (2%)	58	78
13	BH	308/332 (93%)	303 (98%)	5 (2%)	58	78
13	BM	308/332 (93%)	303 (98%)	5 (2%)	58	78
13	BR	308/332 (93%)	303 (98%)	5 (2%)	58	78
13	BW	308/332 (93%)	303 (98%)	5 (2%)	58	78
13	Bb	308/332 (93%)	303 (98%)	5 (2%)	58	78
13	Bg	308/332 (93%)	303 (98%)	5 (2%)	58	78
13	Bl	308/332 (93%)	303 (98%)	5 (2%)	58	78
13	Bq	308/332 (93%)	303 (98%)	5 (2%)	58	78
13	Bv	308/332 (93%)	303 (98%)	5 (2%)	58	78

Continued on next page...

Continued from previous page...

Mol	Chain	Analysed	Rotameric	Outliers	Percentiles	
13	C3	308/332 (93%)	303 (98%)	5 (2%)	58	78
13	C8	308/332 (93%)	303 (98%)	5 (2%)	58	78
13	CB	308/332 (93%)	303 (98%)	5 (2%)	58	78
13	CJ	308/332 (93%)	303 (98%)	5 (2%)	58	78
13	CO	308/332 (93%)	303 (98%)	5 (2%)	58	78
13	CT	308/332 (93%)	303 (98%)	5 (2%)	58	78
13	CY	308/332 (93%)	303 (98%)	5 (2%)	58	78
13	Cd	308/332 (93%)	303 (98%)	5 (2%)	58	78
13	Ci	308/332 (93%)	303 (98%)	5 (2%)	58	78
13	Cn	308/332 (93%)	303 (98%)	5 (2%)	58	78
13	Cs	308/332 (93%)	303 (98%)	5 (2%)	58	78
13	Cx	308/332 (93%)	303 (98%)	5 (2%)	58	78
14	A4	183/215 (85%)	180 (98%)	3 (2%)	58	78
14	A9	183/215 (85%)	180 (98%)	3 (2%)	58	78
14	B2	183/215 (85%)	181 (99%)	2 (1%)	70	84
14	B8	183/215 (85%)	180 (98%)	3 (2%)	58	78
14	BD	183/215 (85%)	180 (98%)	3 (2%)	58	78
14	BI	183/215 (85%)	180 (98%)	3 (2%)	58	78
14	BN	183/215 (85%)	180 (98%)	3 (2%)	58	78
14	BS	183/215 (85%)	180 (98%)	3 (2%)	58	78
14	BX	183/215 (85%)	180 (98%)	3 (2%)	58	78
14	Bc	183/215 (85%)	180 (98%)	3 (2%)	58	78
14	Bh	183/215 (85%)	180 (98%)	3 (2%)	58	78
14	Bm	183/215 (85%)	180 (98%)	3 (2%)	58	78
14	Br	183/215 (85%)	180 (98%)	3 (2%)	58	78
14	Bw	183/215 (85%)	180 (98%)	3 (2%)	58	78
14	C4	183/215 (85%)	180 (98%)	3 (2%)	58	78
14	C9	183/215 (85%)	180 (98%)	3 (2%)	58	78
14	CC	183/215 (85%)	180 (98%)	3 (2%)	58	78
14	CK	183/215 (85%)	180 (98%)	3 (2%)	58	78
14	CP	183/215 (85%)	180 (98%)	3 (2%)	58	78

Continued on next page...

Continued from previous page...

Mol	Chain	Analysed	Rotameric	Outliers	Percentiles	
14	CU	183/215 (85%)	180 (98%)	3 (2%)	58	78
14	CZ	183/215 (85%)	180 (98%)	3 (2%)	58	78
14	Ce	183/215 (85%)	180 (98%)	3 (2%)	58	78
14	Cj	183/215 (85%)	180 (98%)	3 (2%)	58	78
14	Co	183/215 (85%)	180 (98%)	3 (2%)	58	78
14	Ct	183/215 (85%)	180 (98%)	3 (2%)	58	78
14	Cy	183/215 (85%)	180 (98%)	3 (2%)	58	78
15	A0	11/123 (9%)	10 (91%)	1 (9%)	7	29
15	A5	11/123 (9%)	10 (91%)	1 (9%)	7	29
15	B3	11/123 (9%)	10 (91%)	1 (9%)	7	29
15	B9	11/123 (9%)	10 (91%)	1 (9%)	7	29
15	BE	11/123 (9%)	10 (91%)	1 (9%)	7	29
15	BJ	11/123 (9%)	10 (91%)	1 (9%)	7	29
15	BO	11/123 (9%)	10 (91%)	1 (9%)	7	29
15	BT	11/123 (9%)	10 (91%)	1 (9%)	7	29
15	BY	11/123 (9%)	10 (91%)	1 (9%)	7	29
15	Bd	11/123 (9%)	10 (91%)	1 (9%)	7	29
15	Bi	11/123 (9%)	10 (91%)	1 (9%)	7	29
15	Bn	11/123 (9%)	10 (91%)	1 (9%)	7	29
15	Bs	11/123 (9%)	10 (91%)	1 (9%)	7	29
15	Bx	11/123 (9%)	10 (91%)	1 (9%)	7	29
15	C0	11/123 (9%)	10 (91%)	1 (9%)	7	29
15	C5	11/123 (9%)	10 (91%)	1 (9%)	7	29
15	CD	11/123 (9%)	10 (91%)	1 (9%)	7	29
15	CL	11/123 (9%)	10 (91%)	1 (9%)	7	29
15	CQ	11/123 (9%)	10 (91%)	1 (9%)	7	29
15	CV	11/123 (9%)	10 (91%)	1 (9%)	7	29
15	Ca	11/123 (9%)	10 (91%)	1 (9%)	7	29
15	Cf	11/123 (9%)	10 (91%)	1 (9%)	7	29
15	Ck	11/123 (9%)	10 (91%)	1 (9%)	7	29
15	Cp	11/123 (9%)	10 (91%)	1 (9%)	7	29

Continued on next page...

Continued from previous page...

Mol	Chain	Analysed	Rotameric	Outliers	Percentiles	
15	Cu	11/123 (9%)	10 (91%)	1 (9%)	7	29
15	Cz	11/123 (9%)	10 (91%)	1 (9%)	7	29
17	A7	224/285 (79%)	220 (98%)	4 (2%)	54	75
17	B5	224/285 (79%)	220 (98%)	4 (2%)	54	75
17	BB	224/285 (79%)	220 (98%)	4 (2%)	54	75
17	BG	224/285 (79%)	220 (98%)	4 (2%)	54	75
17	BL	224/285 (79%)	220 (98%)	4 (2%)	54	75
17	BQ	224/285 (79%)	220 (98%)	4 (2%)	54	75
17	BV	224/285 (79%)	220 (98%)	4 (2%)	54	75
17	Ba	224/285 (79%)	220 (98%)	4 (2%)	54	75
17	Bf	224/285 (79%)	220 (98%)	4 (2%)	54	75
17	Bk	224/285 (79%)	220 (98%)	4 (2%)	54	75
17	Bp	224/285 (79%)	220 (98%)	4 (2%)	54	75
17	Bu	224/285 (79%)	220 (98%)	4 (2%)	54	75
17	Bz	224/285 (79%)	220 (98%)	4 (2%)	54	75
17	C2	224/285 (79%)	219 (98%)	5 (2%)	47	71
17	C7	224/285 (79%)	220 (98%)	4 (2%)	54	75
17	CA	224/285 (79%)	220 (98%)	4 (2%)	54	75
17	CF	224/285 (79%)	220 (98%)	4 (2%)	54	75
17	CI	224/285 (79%)	220 (98%)	4 (2%)	54	75
17	CN	224/285 (79%)	220 (98%)	4 (2%)	54	75
17	CS	224/285 (79%)	220 (98%)	4 (2%)	54	75
17	CX	224/285 (79%)	220 (98%)	4 (2%)	54	75
17	Cc	224/285 (79%)	220 (98%)	4 (2%)	54	75
17	Ch	224/285 (79%)	220 (98%)	4 (2%)	54	75
17	Cm	224/285 (79%)	220 (98%)	4 (2%)	54	75
17	Cr	224/285 (79%)	220 (98%)	4 (2%)	54	75
17	Cw	224/285 (79%)	220 (98%)	4 (2%)	54	75
18	CG	239/260 (92%)	227 (95%)	12 (5%)	20	52
18	DA	240/260 (92%)	231 (96%)	9 (4%)	28	59
18	DD	239/260 (92%)	227 (95%)	12 (5%)	20	52

Continued on next page...

Continued from previous page...

Mol	Chain	Analysed	Rotameric	Outliers	Percentiles	
18	DE	240/260 (92%)	231 (96%)	9 (4%)	28	59
18	DH	239/260 (92%)	227 (95%)	12 (5%)	20	52
18	DI	240/260 (92%)	231 (96%)	9 (4%)	28	59
18	DL	239/260 (92%)	227 (95%)	12 (5%)	20	52
18	DM	240/260 (92%)	231 (96%)	9 (4%)	28	59
18	DP	239/260 (92%)	227 (95%)	12 (5%)	20	52
18	DQ	240/260 (92%)	231 (96%)	9 (4%)	28	59
18	DT	239/260 (92%)	227 (95%)	12 (5%)	20	52
18	DU	240/260 (92%)	231 (96%)	9 (4%)	28	59
18	DX	239/260 (92%)	227 (95%)	12 (5%)	20	52
18	DY	240/260 (92%)	231 (96%)	9 (4%)	28	59
18	Db	239/260 (92%)	227 (95%)	12 (5%)	20	52
18	Dc	240/260 (92%)	231 (96%)	9 (4%)	28	59
18	Df	239/260 (92%)	227 (95%)	12 (5%)	20	52
18	Dg	240/260 (92%)	231 (96%)	9 (4%)	28	59
18	Dj	239/260 (92%)	227 (95%)	12 (5%)	20	52
18	Dk	240/260 (92%)	231 (96%)	9 (4%)	28	59
18	Dn	239/260 (92%)	227 (95%)	12 (5%)	20	52
18	Do	240/260 (92%)	231 (96%)	9 (4%)	28	59
18	Dr	239/260 (92%)	227 (95%)	12 (5%)	20	52
18	Ds	240/260 (92%)	231 (96%)	9 (4%)	28	59
18	Dv	239/260 (92%)	227 (95%)	12 (5%)	20	52
18	Dw	240/260 (92%)	231 (96%)	9 (4%)	28	59
19	DB	151/175 (86%)	144 (95%)	7 (5%)	23	54
19	DC	151/175 (86%)	143 (95%)	8 (5%)	19	50
19	DF	151/175 (86%)	144 (95%)	7 (5%)	23	54
19	DG	151/175 (86%)	143 (95%)	8 (5%)	19	50
19	DJ	151/175 (86%)	144 (95%)	7 (5%)	23	54
19	DK	151/175 (86%)	143 (95%)	8 (5%)	19	50
19	DN	151/175 (86%)	145 (96%)	6 (4%)	27	58
19	DO	151/175 (86%)	143 (95%)	8 (5%)	19	50

Continued on next page...

Continued from previous page...

Mol	Chain	Analysed	Rotameric	Outliers	Percentiles	
19	DR	151/175 (86%)	144 (95%)	7 (5%)	23	54
19	DS	151/175 (86%)	143 (95%)	8 (5%)	19	50
19	DV	151/175 (86%)	144 (95%)	7 (5%)	23	54
19	DW	151/175 (86%)	143 (95%)	8 (5%)	19	50
19	DZ	151/175 (86%)	144 (95%)	7 (5%)	23	54
19	Da	151/175 (86%)	143 (95%)	8 (5%)	19	50
19	Dd	151/175 (86%)	144 (95%)	7 (5%)	23	54
19	De	151/175 (86%)	143 (95%)	8 (5%)	19	50
19	Dh	151/175 (86%)	144 (95%)	7 (5%)	23	54
19	Di	151/175 (86%)	143 (95%)	8 (5%)	19	50
19	DI	151/175 (86%)	145 (96%)	6 (4%)	27	58
19	Dm	151/175 (86%)	143 (95%)	8 (5%)	19	50
19	Dp	151/175 (86%)	144 (95%)	7 (5%)	23	54
19	Dq	151/175 (86%)	143 (95%)	8 (5%)	19	50
19	Dt	151/175 (86%)	144 (95%)	7 (5%)	23	54
19	Du	151/175 (86%)	143 (95%)	8 (5%)	19	50
19	Dx	151/175 (86%)	145 (96%)	6 (4%)	27	58
19	Dy	151/175 (86%)	143 (95%)	8 (5%)	19	50
All	All	60386/97839 (62%)	58279 (96%)	2107 (4%)	33	61

5 of 2107 residues with a non-rotameric sidechain are listed below:

Mol	Chain	Res	Type
7	ET	395	THR
7	Ea	194	ARG
7	ET	380	THR
7	Ez	395	THR
6	O	53	THR

Sometimes sidechains can be flipped to improve hydrogen bonding and reduce clashes. 5 of 1904 such sidechains are listed below:

Mol	Chain	Res	Type
5	T	51	GLN
7	EM	305	GLN
13	CB	156	GLN

Continued on next page...

Continued from previous page...

Mol	Chain	Res	Type
7	D5	445	ASN
7	E2	305	GLN

5.3.3 RNA [i](#)

There are no RNA molecules in this entry.

5.4 Non-standard residues in protein, DNA, RNA chains [i](#)

There are no non-standard protein/DNA/RNA residues in this entry.

5.5 Carbohydrates [i](#)

There are no oligosaccharides in this entry.

5.6 Ligand geometry [i](#)

9 ligands are modelled in this entry.

In the following table, the Counts columns list the number of bonds (or angles) for which Mogul statistics could be retrieved, the number of bonds (or angles) that are observed in the model and the number of bonds (or angles) that are defined in the Chemical Component Dictionary. The Link column lists molecule types, if any, to which the group is linked. The Z score for a bond length (or angle) is the number of standard deviations the observed value is removed from the expected value. A bond length (or angle) with $|Z| > 2$ is considered an outlier worth inspection. RMSZ is the root-mean-square of all Z scores of the bond lengths (or angles).

Mol	Type	Chain	Res	Link	Bond lengths			Bond angles		
					Counts	RMSZ	$\# Z > 2$	Counts	RMSZ	$\# Z > 2$
23	XKP	e	201	-	31,31,32	0.36	0	34,36,37	0.43	0
22	PGT	t	202	-	50,50,50	0.30	0	53,56,56	0.37	0
23	XKP	s	201	-	31,31,32	0.37	0	34,36,37	0.35	0
23	XKP	t	201	-	31,31,32	0.37	0	34,36,37	0.38	0
23	XKP	u	201	-	31,31,32	0.38	0	34,36,37	0.43	0
22	PGT	2	301	-	50,50,50	0.31	0	53,56,56	0.46	0
22	PGT	e	202	-	50,50,50	0.33	0	53,56,56	0.45	0
22	PGT	v	202	-	50,50,50	0.30	0	53,56,56	0.38	0
23	XKP	v	201	-	31,31,32	0.37	0	34,36,37	0.49	0

In the following table, the Chirals column lists the number of chiral outliers, the number of chiral centers analysed, the number of these observed in the model and the number defined in the

Chemical Component Dictionary. Similar counts are reported in the Torsion and Rings columns. '-' means no outliers of that kind were identified.

Mol	Type	Chain	Res	Link	Chirals	Torsions	Rings
23	XKP	e	201	-	-	17/35/35/36	-
22	PGT	t	202	-	-	37/55/55/55	-
23	XKP	s	201	-	-	20/35/35/36	-
23	XKP	t	201	-	-	25/35/35/36	-
23	XKP	u	201	-	-	18/35/35/36	-
22	PGT	2	301	-	-	34/55/55/55	-
22	PGT	e	202	-	-	32/55/55/55	-
22	PGT	v	202	-	-	39/55/55/55	-
23	XKP	v	201	-	-	20/35/35/36	-

There are no bond length outliers.

There are no bond angle outliers.

There are no chirality outliers.

5 of 242 torsion outliers are listed below:

Mol	Chain	Res	Type	Atoms
22	2	301	PGT	C32-C31-O2-C2
22	2	301	PGT	C1-O3P-P-O1P
22	2	301	PGT	C4-O4P-P-O3P
22	2	301	PGT	C4-O4P-P-O1P
22	2	301	PGT	C5-C4-O4P-P

There are no ring outliers.

9 monomers are involved in 56 short contacts:

Mol	Chain	Res	Type	Clashes	Symm-Clashes
23	e	201	XKP	1	0
22	t	202	PGT	17	0
23	s	201	XKP	1	0
23	t	201	XKP	2	0
23	u	201	XKP	3	0
22	2	301	PGT	12	0
22	e	202	PGT	4	0
22	v	202	PGT	12	0
23	v	201	XKP	6	0

The following is a two-dimensional graphical depiction of Mogul quality analysis of bond lengths,

bond angles, torsion angles, and ring geometry for all instances of the Ligand of Interest. In addition, ligands with molecular weight > 250 and outliers as shown on the validation Tables will also be included. For torsion angles, if less than 5% of the Mogul distribution of torsion angles is within 10 degrees of the torsion angle in question, then that torsion angle is considered an outlier. Any bond that is central to one or more torsion angles identified as an outlier by Mogul will be highlighted in the graph. For rings, the root-mean-square deviation (RMSD) between the ring in question and similar rings identified by Mogul is calculated over all ring torsion angles. If the average RMSD is greater than 60 degrees and the minimal RMSD between the ring in question and any Mogul-identified rings is also greater than 60 degrees, then that ring is considered an outlier. The outliers are highlighted in purple. The color gray indicates Mogul did not find sufficient equivalents in the CSD to analyse the geometry.

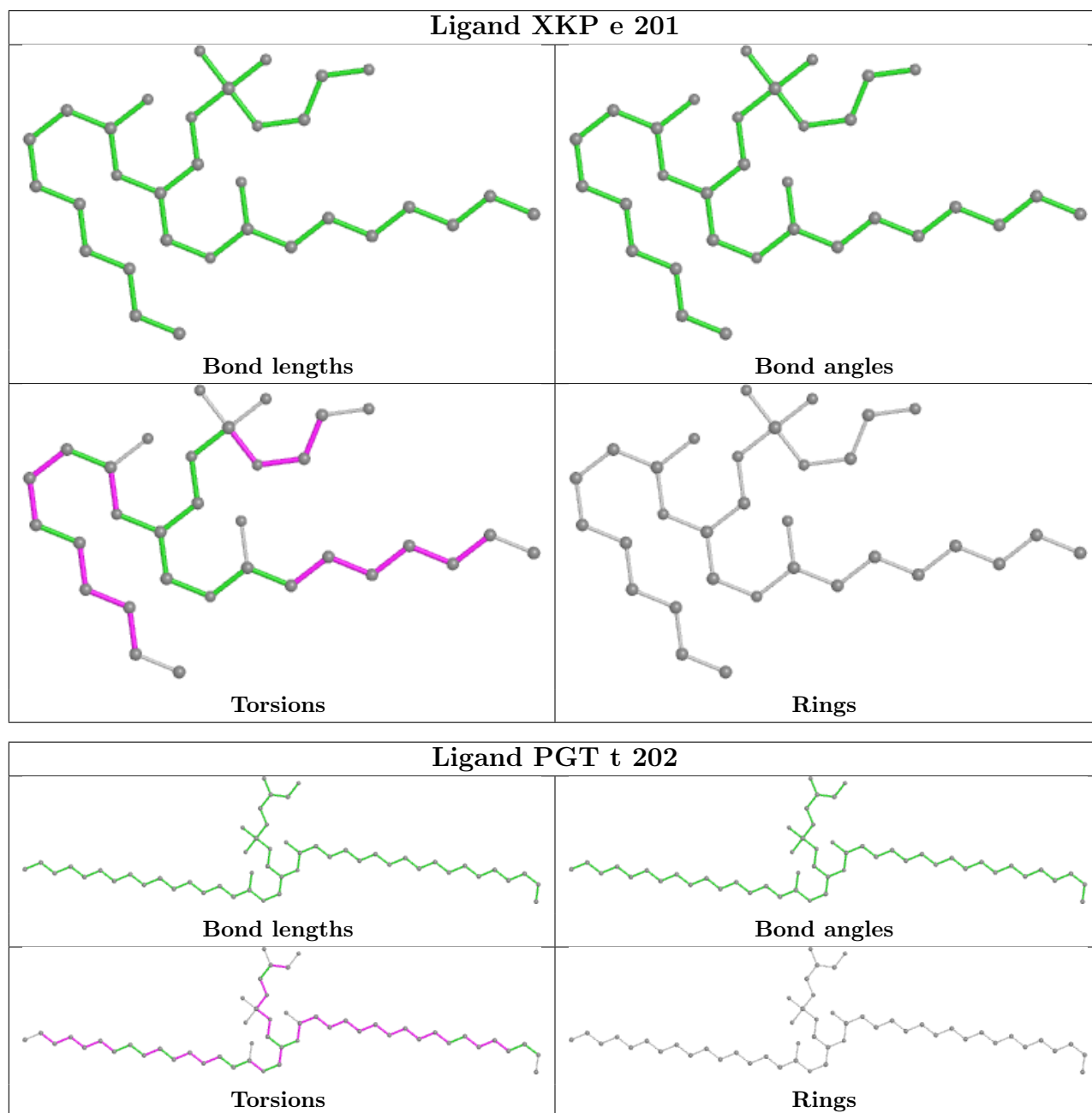

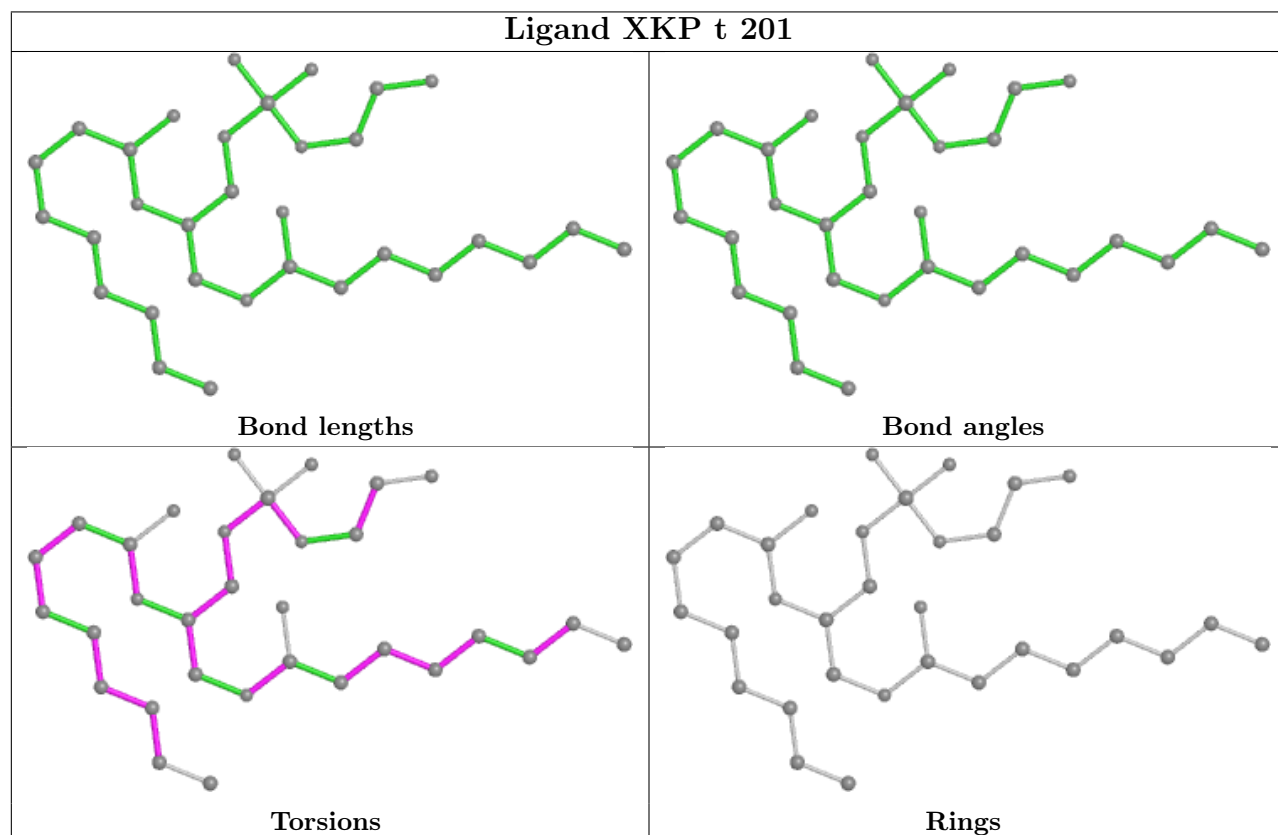
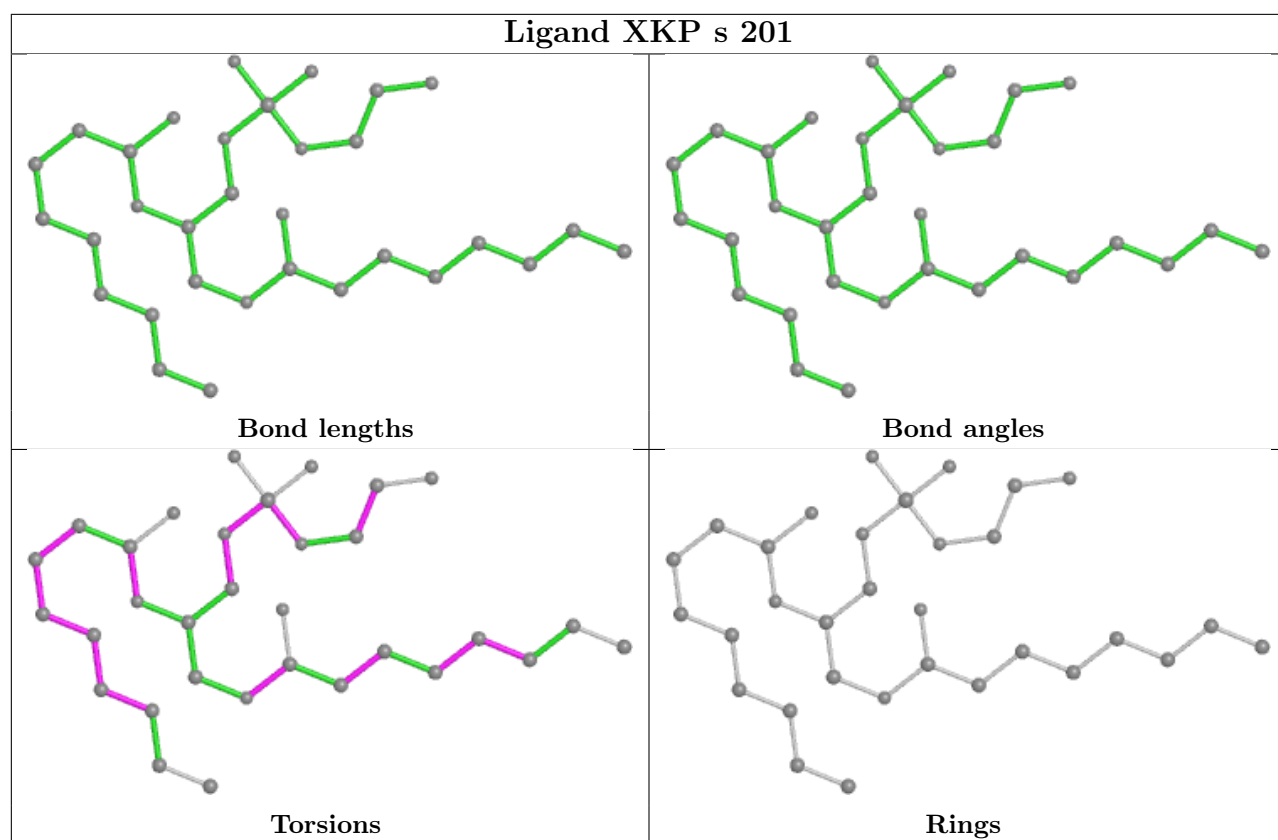

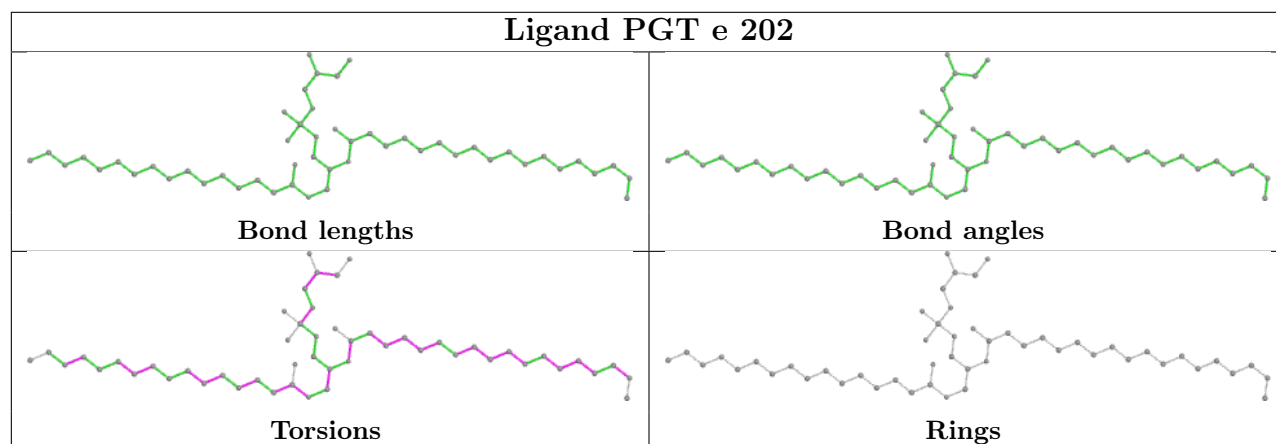
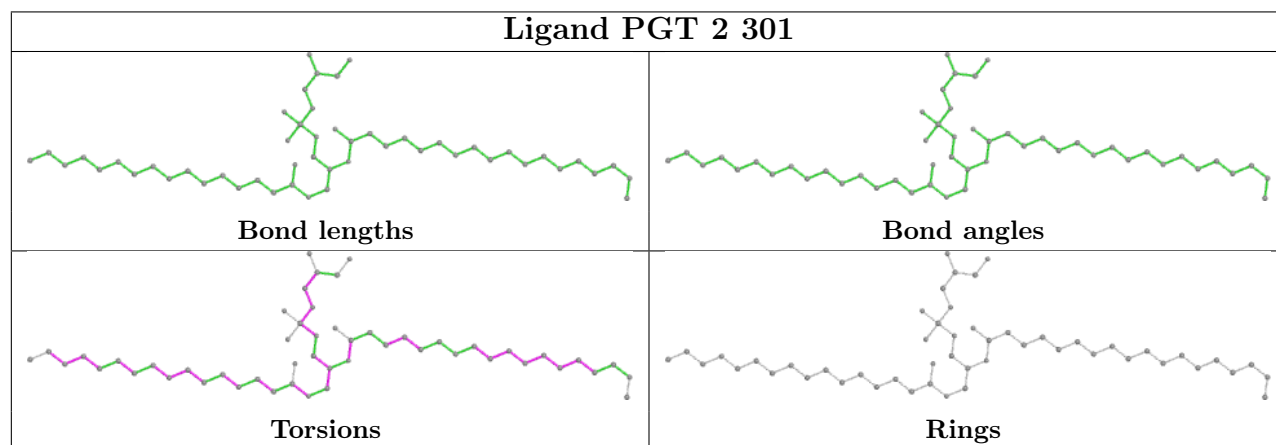
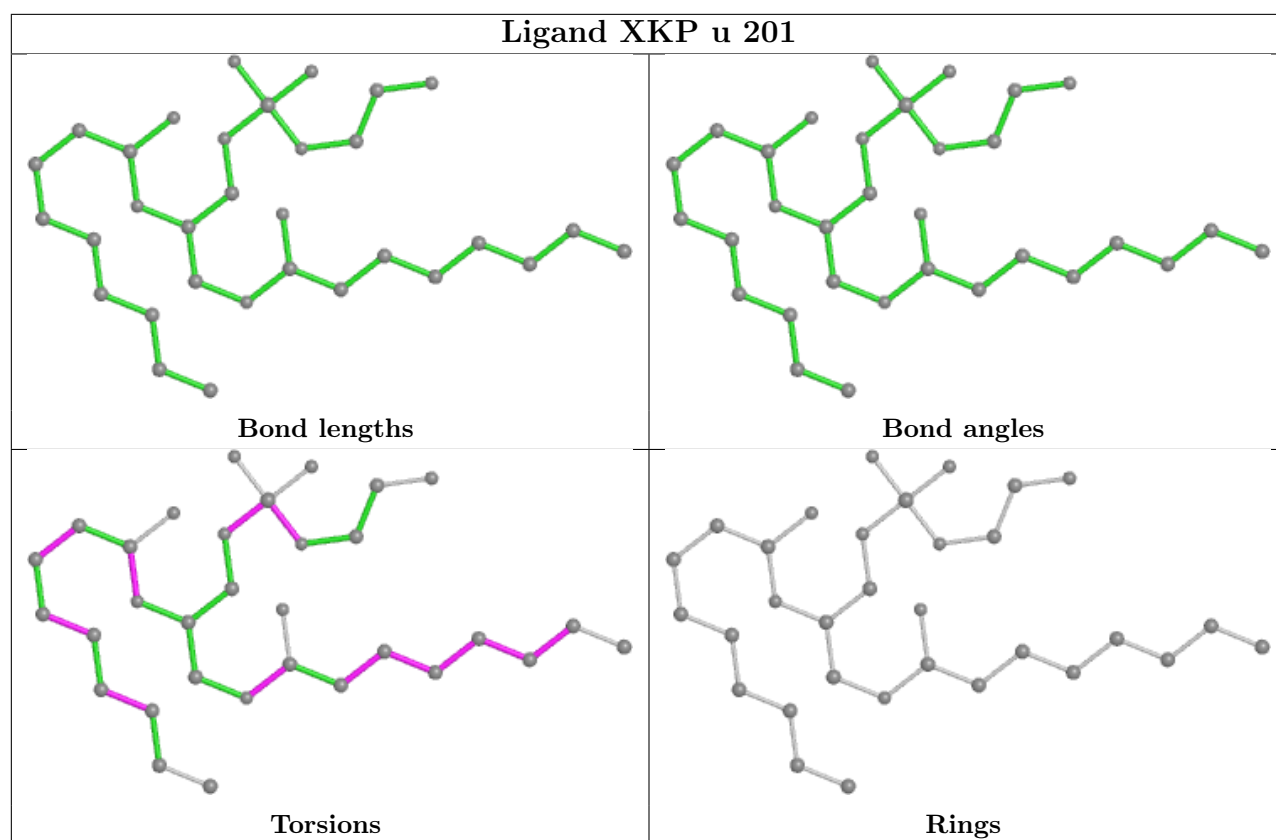

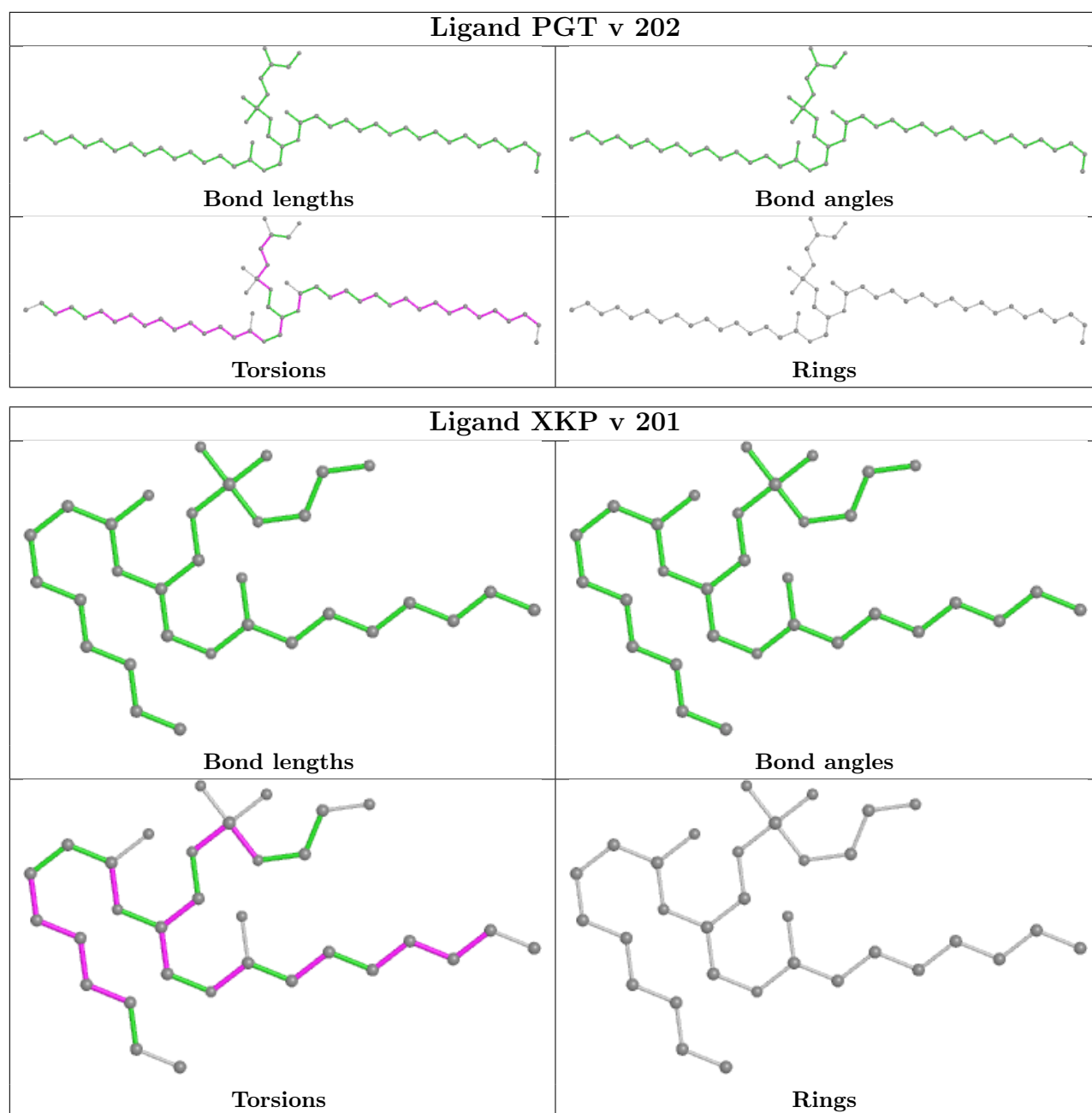

5.7 Other polymers [i](#)

There are no such residues in this entry.

5.8 Polymer linkage issues [i](#)

There are no chain breaks in this entry.

6 Map visualisation [i](#)

This section contains visualisations of the EMDB entry EMD-39790. These allow visual inspection of the internal detail of the map and identification of artifacts.

Images derived from a raw map, generated by summing the deposited half-maps, are presented below the corresponding image components of the primary map to allow further visual inspection and comparison with those of the primary map.

6.1 Orthogonal projections [i](#)

6.1.1 Primary map

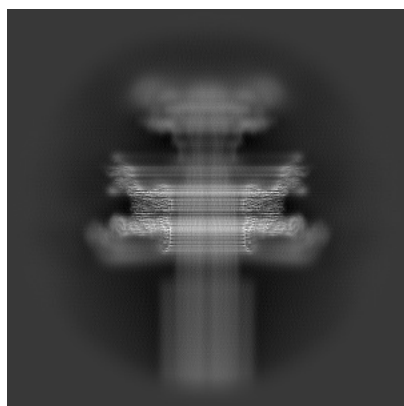

X

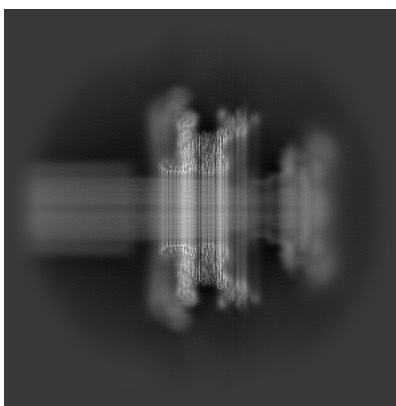

Y

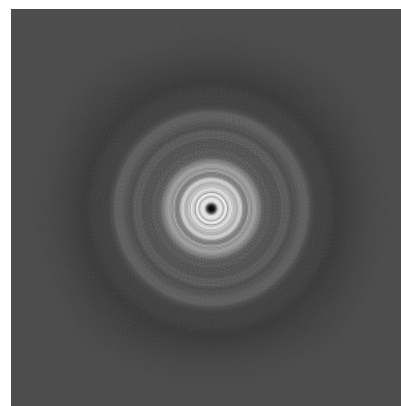

Z

6.1.2 Raw map

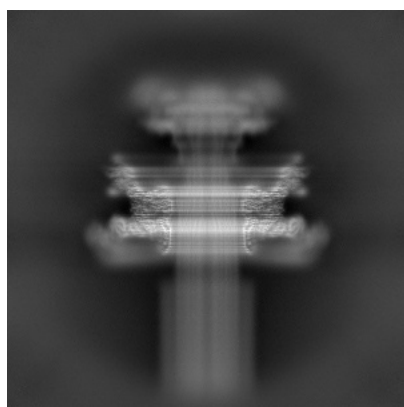

X

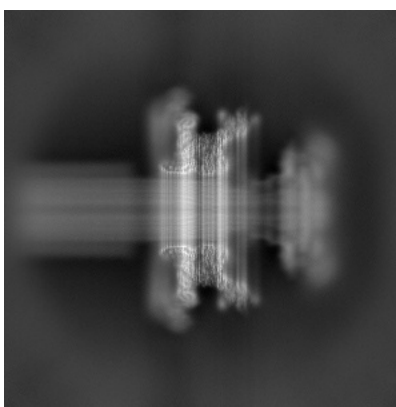

Y

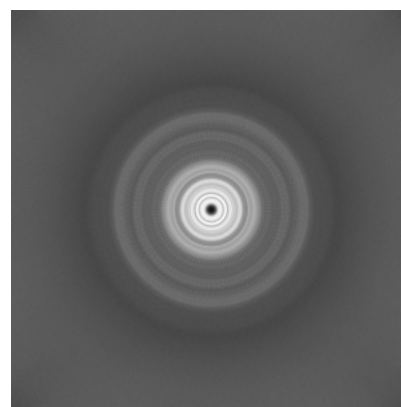

Z

The images above show the map projected in three orthogonal directions.

6.2 Central slices [i](#)

6.2.1 Primary map

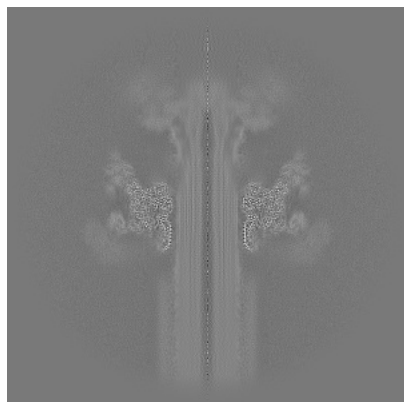

X Index: 310

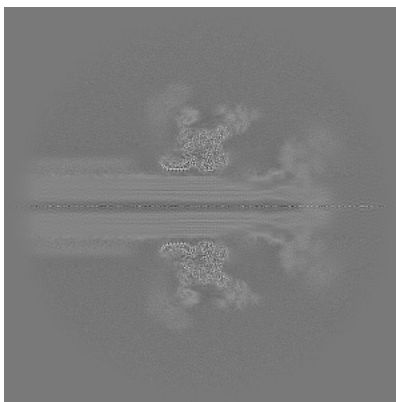

Y Index: 310

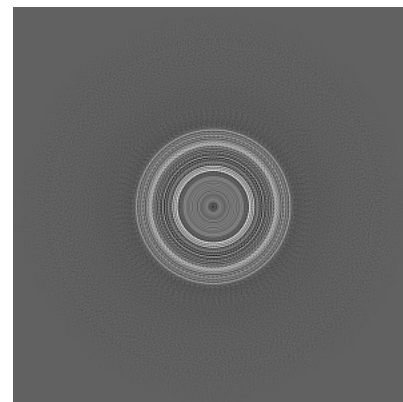

Z Index: 310

6.2.2 Raw map

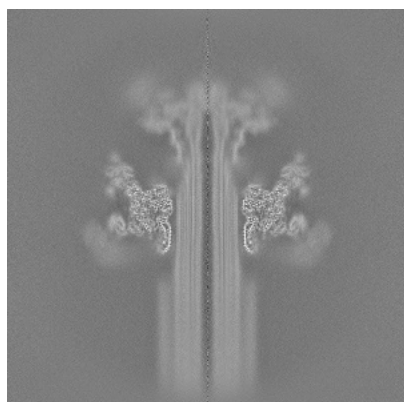

X Index: 310

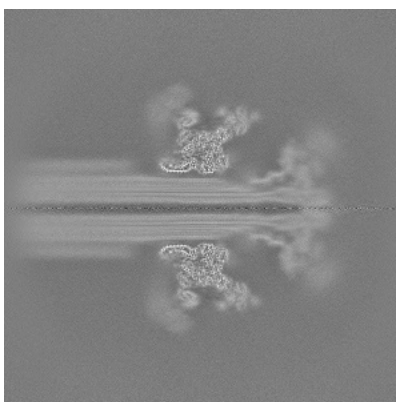

Y Index: 310

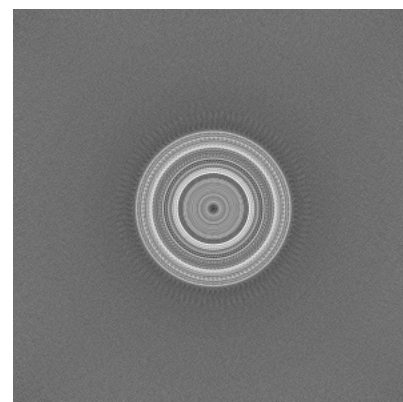

Z Index: 310

The images above show central slices of the map in three orthogonal directions.

6.3 Largest variance slices [i](#)

6.3.1 Primary map

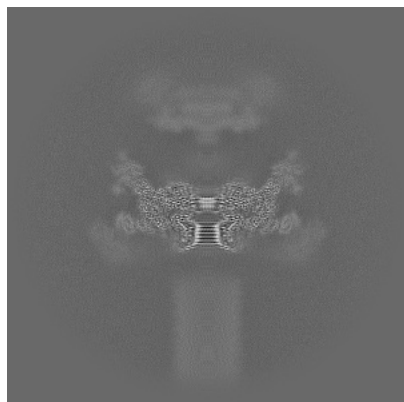

X Index: 366

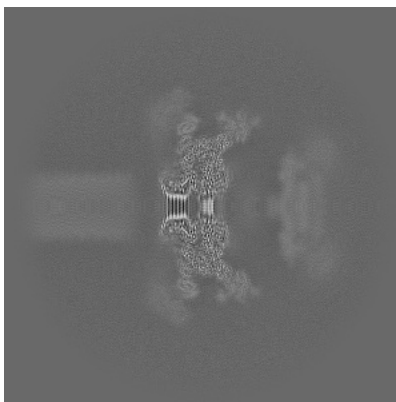

Y Index: 254

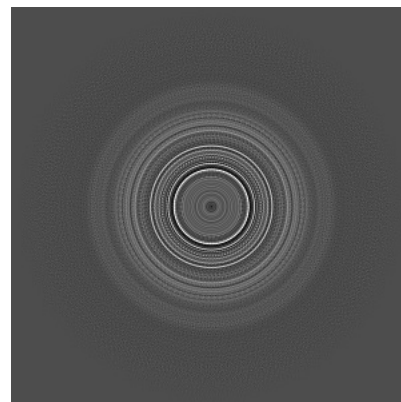

Z Index: 279

6.3.2 Raw map

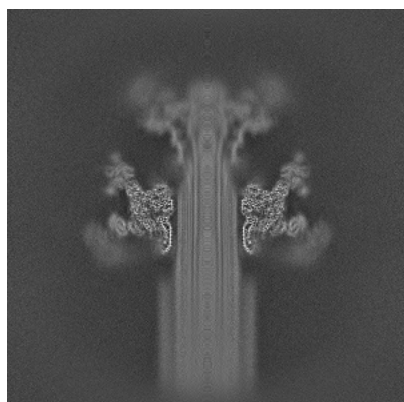

X Index: 298

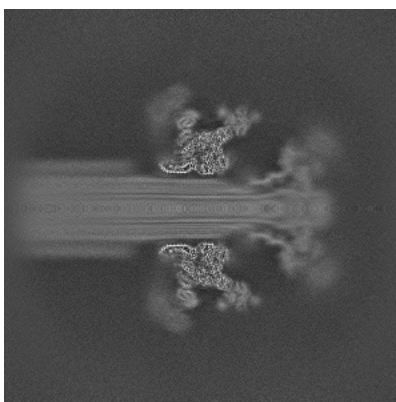

Y Index: 298

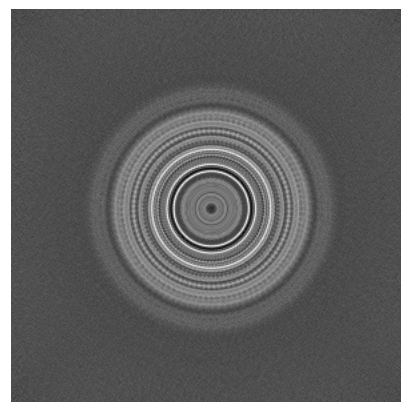

Z Index: 282

The images above show the largest variance slices of the map in three orthogonal directions.

6.4 Orthogonal standard-deviation projections (False-color) [i](#)

6.4.1 Primary map

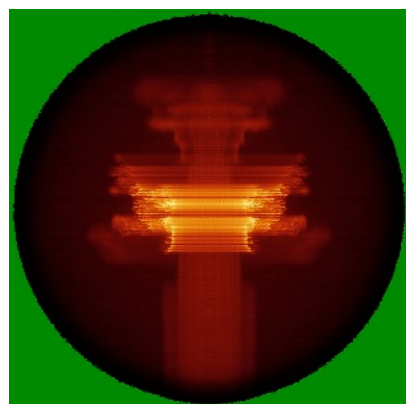

X

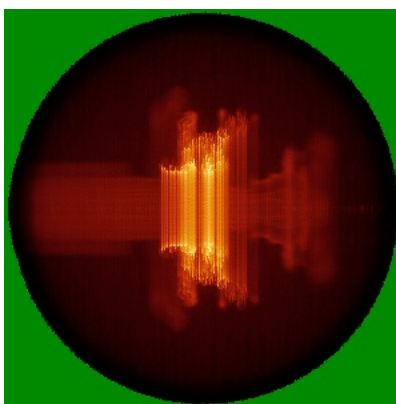

Y

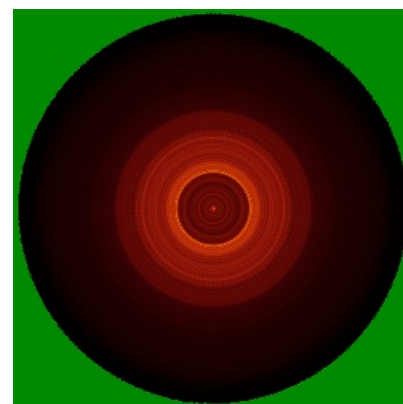

Z

6.4.2 Raw map

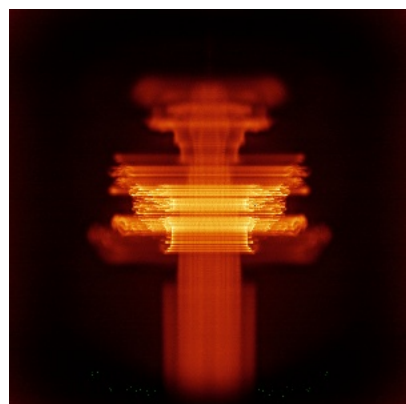

X

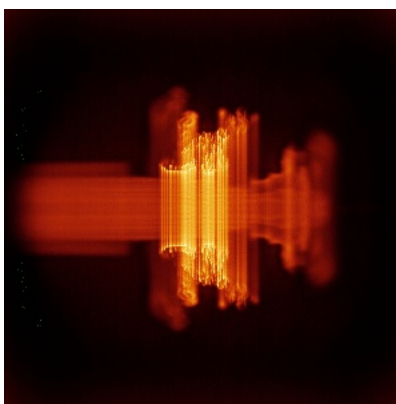

Y

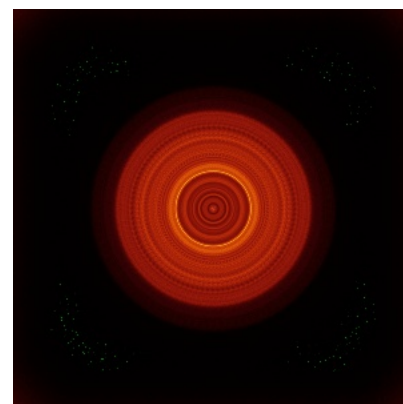

Z

The images above show the map standard deviation projections with false color in three orthogonal directions. Minimum values are shown in green, max in blue, and dark to light orange shades represent small to large values respectively.

6.5 Orthogonal surface views [i](#)

6.5.1 Primary map

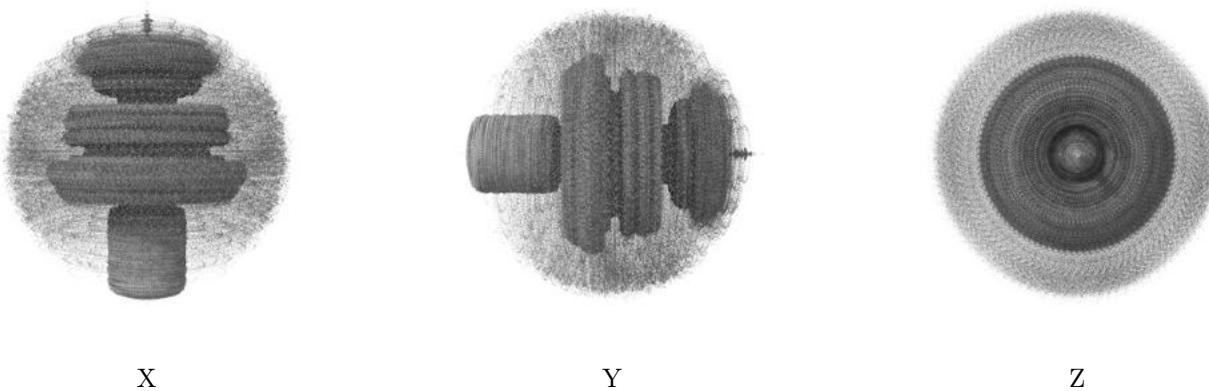

The images above show the 3D surface view of the map at the recommended contour level 0.05. These images, in conjunction with the slice images, may facilitate assessment of whether an appropriate contour level has been provided.

6.5.2 Raw map

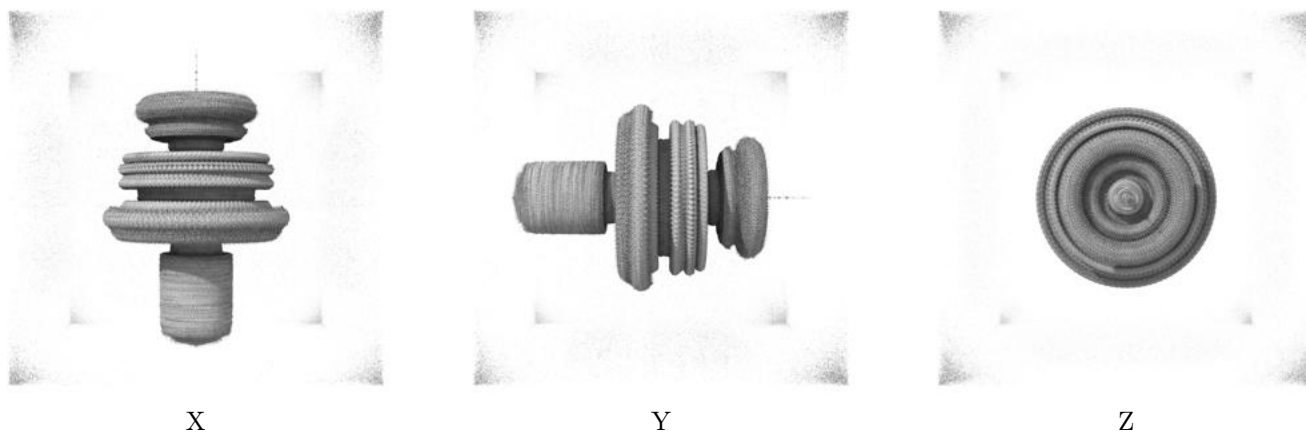

These images show the 3D surface of the raw map. The raw map's contour level was selected so that its surface encloses the same volume as the primary map does at its recommended contour level.

6.6 Mask visualisation [i](#)

This section was not generated. No masks/segmentation were deposited.

7 Map analysis [i](#)

This section contains the results of statistical analysis of the map.

7.1 Map-value distribution [i](#)

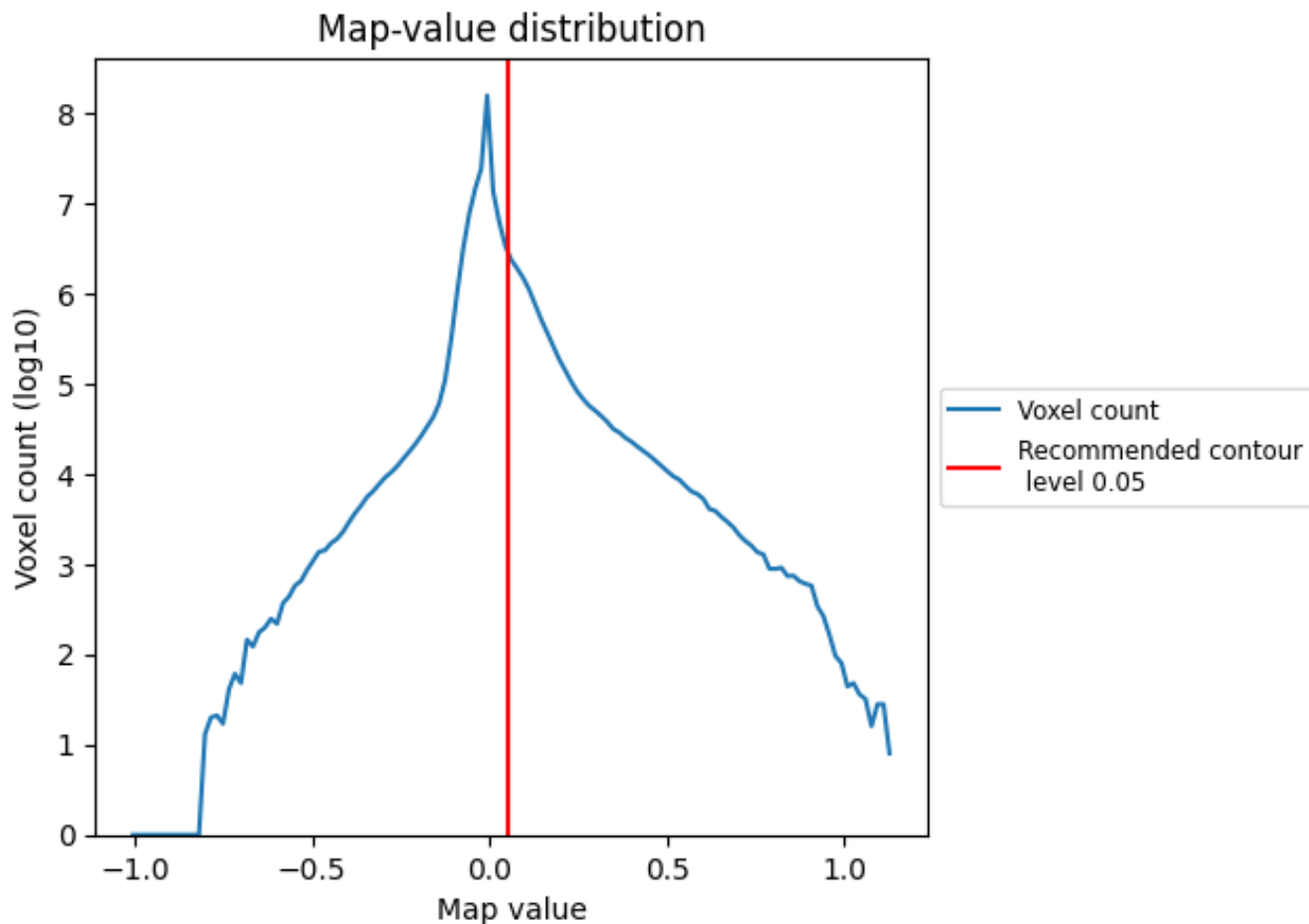

The map-value distribution is plotted in 128 intervals along the x-axis. The y-axis is logarithmic. A spike in this graph at zero usually indicates that the volume has been masked.

7.2 Volume estimate [i](#)

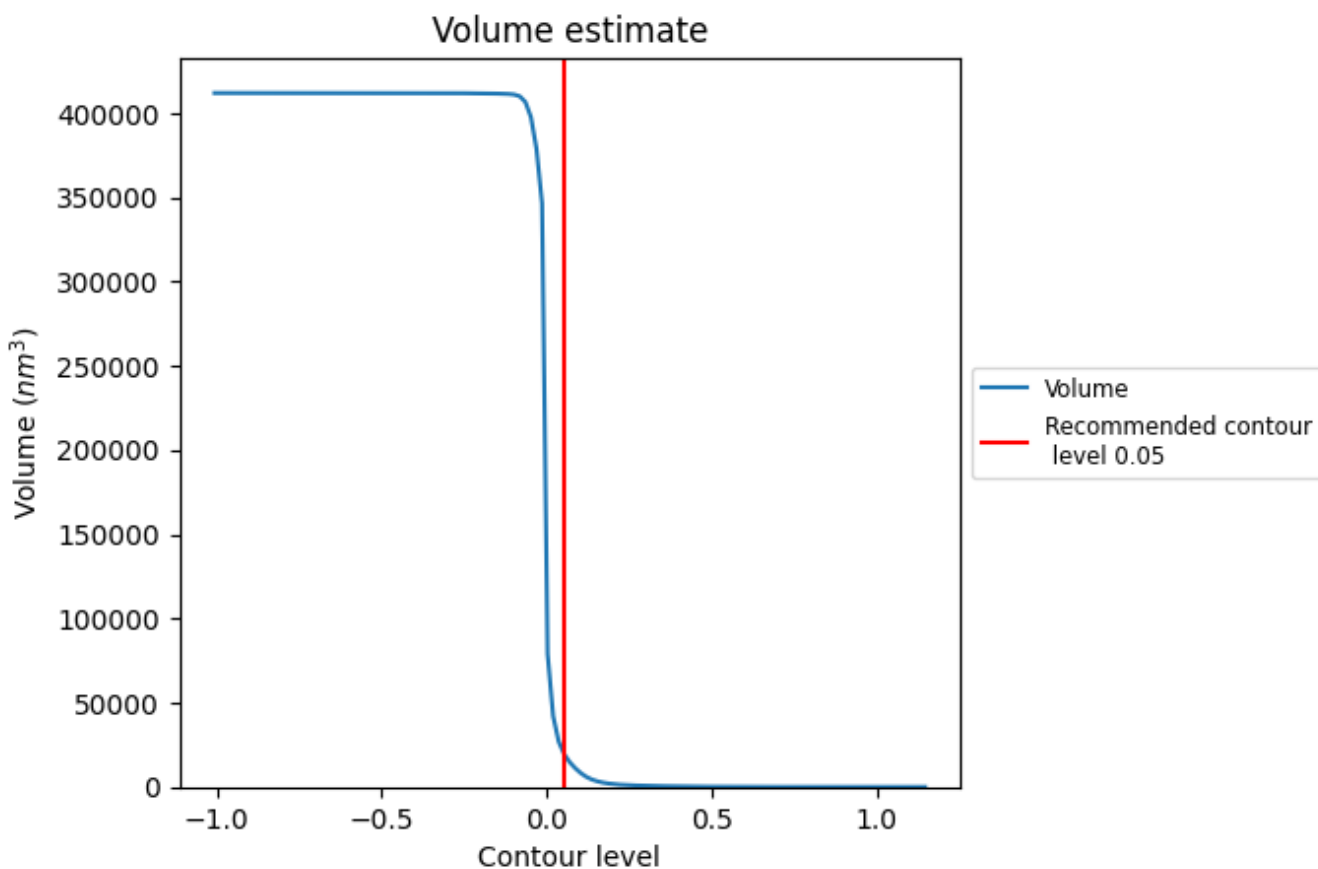

The volume at the recommended contour level is 20676 nm^3 ; this corresponds to an approximate mass of 18677 kDa.

The volume estimate graph shows how the enclosed volume varies with the contour level. The recommended contour level is shown as a vertical line and the intersection between the line and the curve gives the volume of the enclosed surface at the given level.

7.3 Rotationally averaged power spectrum [i](#)

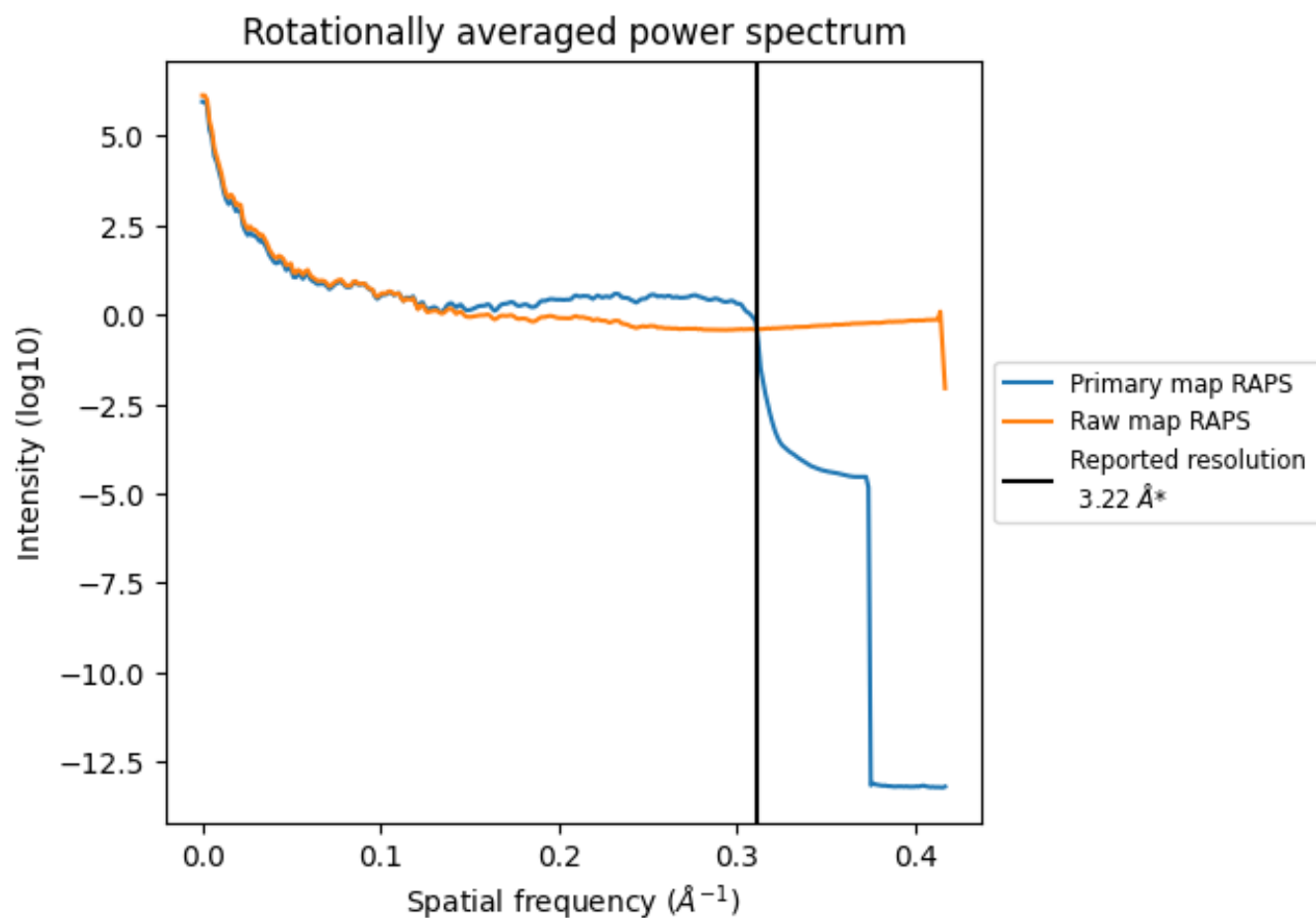

*Reported resolution corresponds to spatial frequency of 0.311 Å⁻¹

8 Fourier-Shell correlation [i](#)

Fourier-Shell Correlation (FSC) is the most commonly used method to estimate the resolution of single-particle and subtomogram-averaged maps. The shape of the curve depends on the imposed symmetry, mask and whether or not the two 3D reconstructions used were processed from a common reference. The reported resolution is shown as a black line. A curve is displayed for the half-bit criterion in addition to lines showing the 0.143 gold standard cut-off and 0.5 cut-off.

8.1 FSC [i](#)

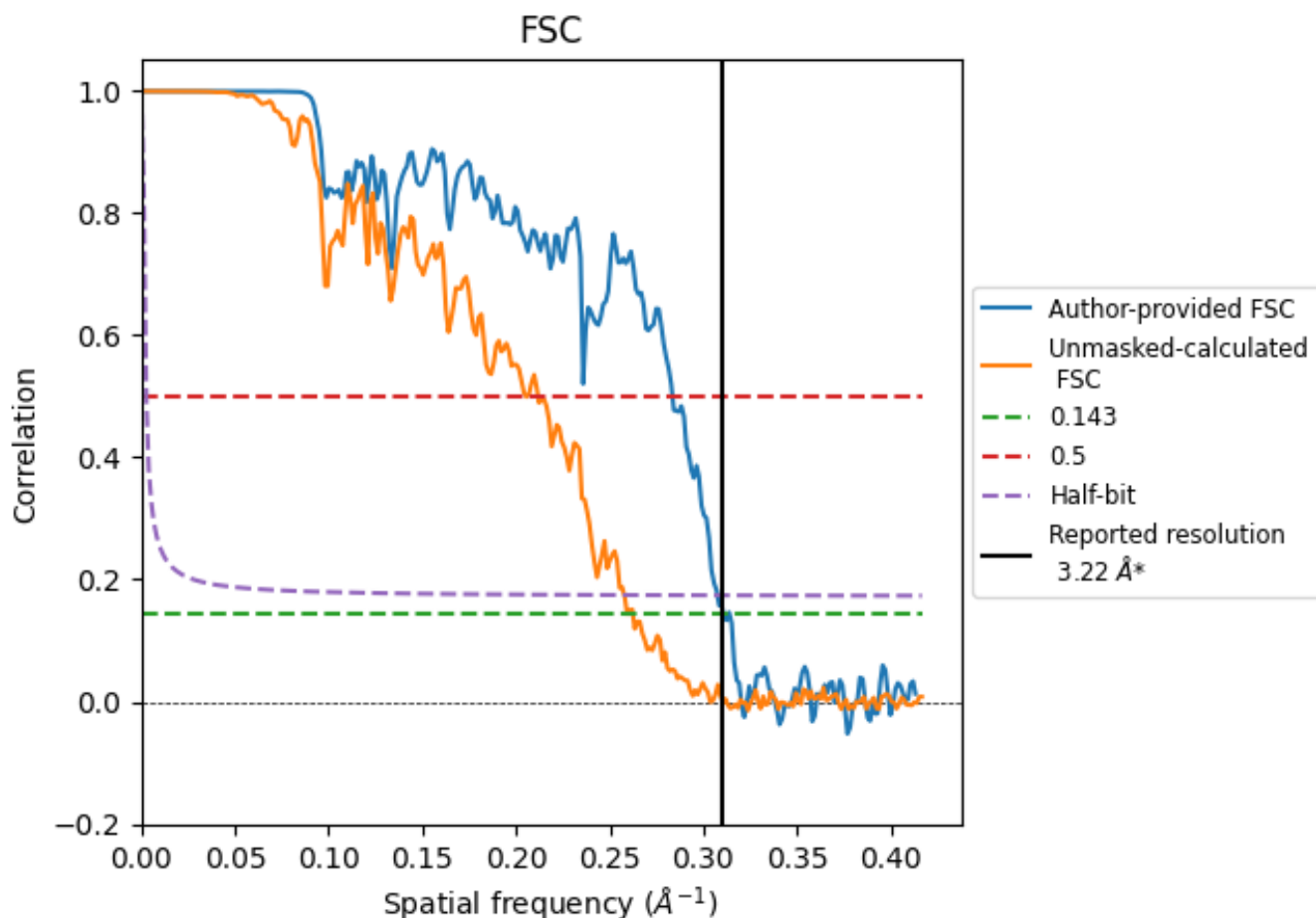

*Reported resolution corresponds to spatial frequency of 0.311 Å⁻¹

8.2 Resolution estimates [i](#)

Resolution estimate (Å)	Estimation criterion (FSC cut-off)		
	0.143	0.5	Half-bit
Reported by author	3.22	-	-
Author-provided FSC curve	3.22	3.53	3.25
Unmasked-calculated*	3.81	4.87	3.88

*Resolution estimate based on FSC curve calculated by comparison of deposited half-maps. The value from deposited half-maps intersecting FSC 0.143 CUT-OFF 3.81 differs from the reported value 3.22 by more than 10 %

9 Map-model fit [i](#)

This section contains information regarding the fit between EMDB map EMD-39790 and PDB model 8Z60. Per-residue inclusion information can be found in section 3 on page 41.

9.1 Map-model overlay [i](#)

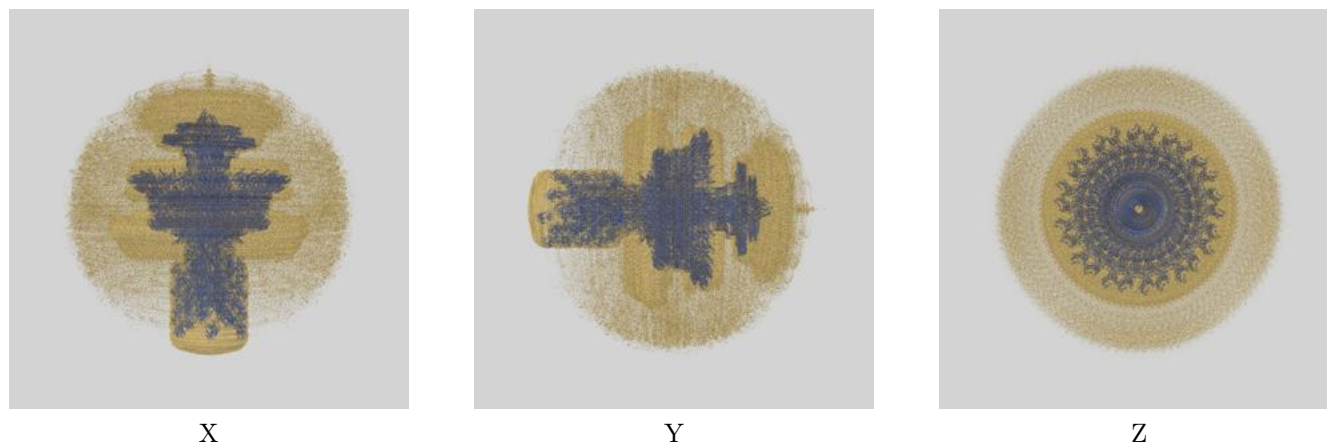

The images above show the 3D surface view of the map at the recommended contour level 0.05 at 50% transparency in yellow overlaid with a ribbon representation of the model coloured in blue. These images allow for the visual assessment of the quality of fit between the atomic model and the map.

9.2 Q-score mapped to coordinate model [\(i\)](#)

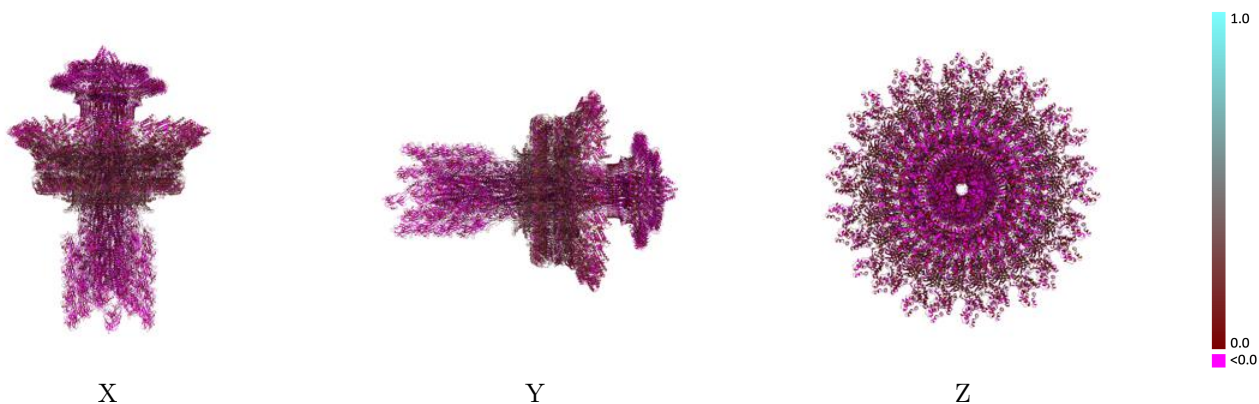

The images above show the model with each residue coloured according its Q-score. This shows their resolvability in the map with higher Q-score values reflecting better resolvability. Please note: Q-score is calculating the resolvability of atoms, and thus high values are only expected at resolutions at which atoms can be resolved. Low Q-score values may therefore be expected for many entries.

9.3 Atom inclusion mapped to coordinate model [\(i\)](#)

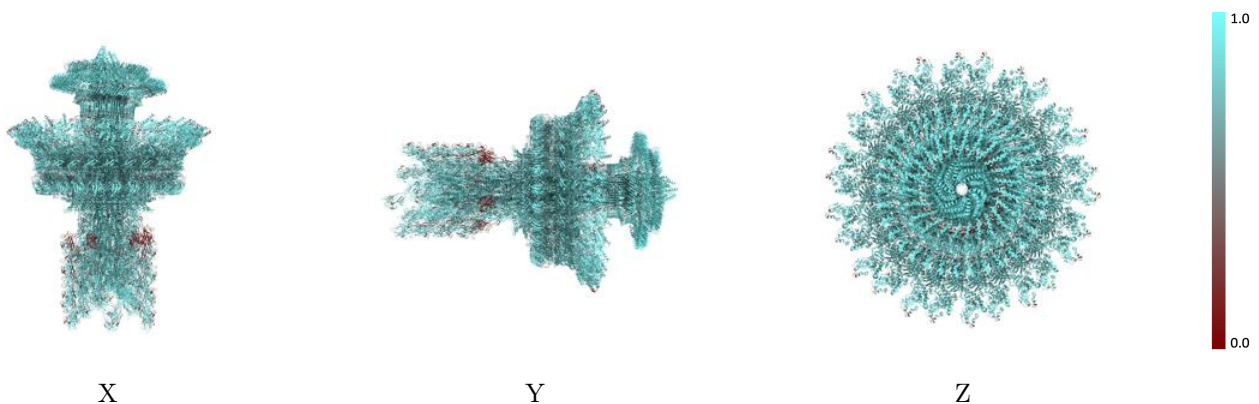

The images above show the model with each residue coloured according to its atom inclusion. This shows to what extent they are inside the map at the recommended contour level (0.05).



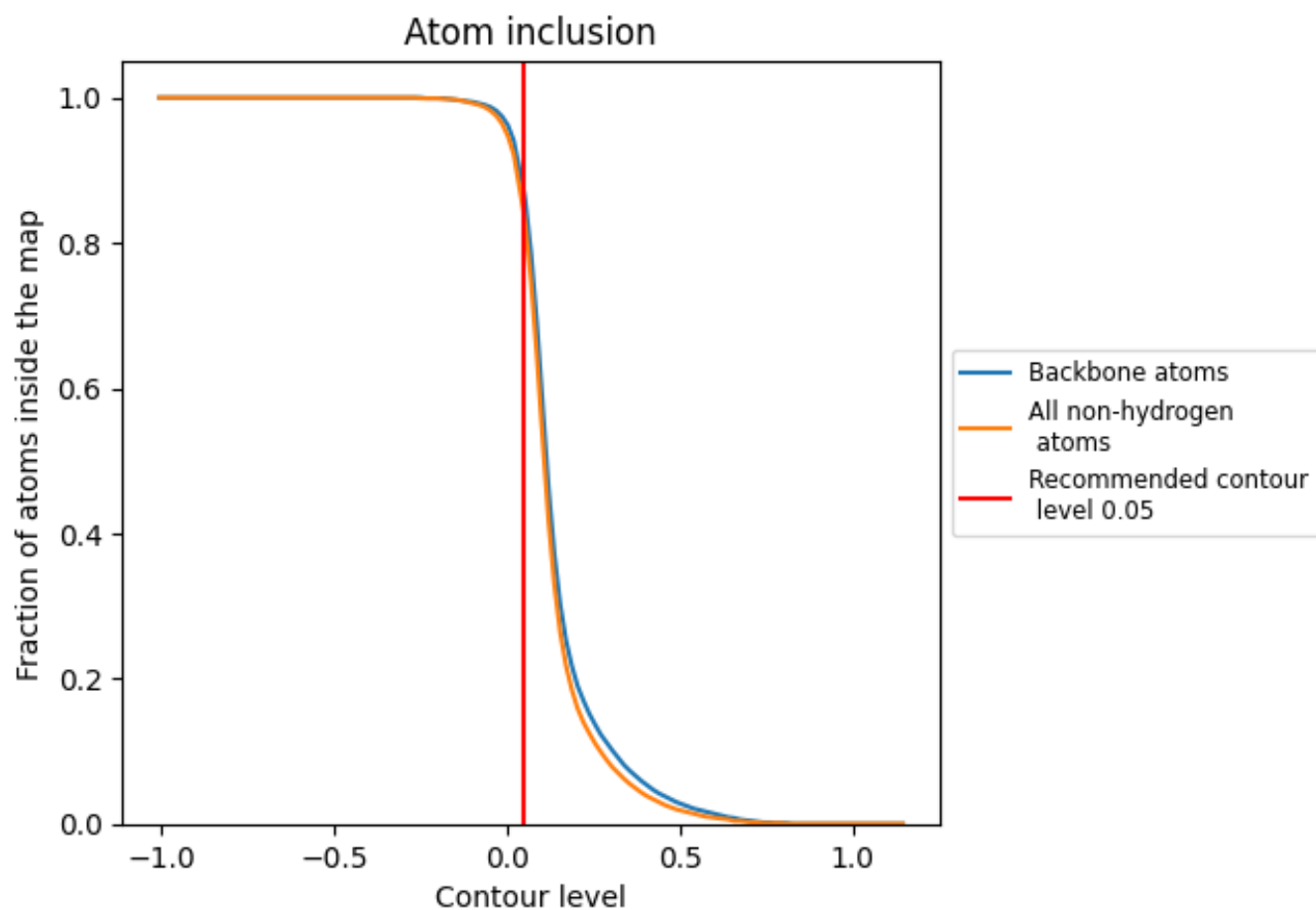



































































9.4 Atom inclusion [i](#)



At the recommended contour level, 87% of all backbone atoms, 84% of all non-hydrogen atoms, are inside the map.

9.5 Map-model fit summary

The table lists the average atom inclusion at the recommended contour level (0.05) and Q-score for the entire model and for each chain.

Chain	Atom inclusion	Q-score
All	 0.8370	 0.0960
0	 0.1540	 -0.0150
1	 0.8530	 0.0110
2	 0.8640	 0.0340
3	 0.9200	 -0.0200
4	 0.9580	 0.0060
5	 0.9480	 0.0040
6	 0.9760	 0.0260
7	 0.9730	 0.0650
8	 0.9360	 -0.0120
9	 0.2150	 0.0180
A	 0.8830	 0.0520
A0	 0.8000	 0.2080
A1	 0.6480	 0.0340
A2	 0.6130	 0.0170
A3	 0.5970	 0.0240
A4	 0.8130	 0.2290
A5	 0.7790	 0.1700
A6	 0.6460	 0.0570
A7	 0.8170	 0.2080
A8	 0.8080	 0.1920
A9	 0.8110	 0.2290
AA	 0.5330	 0.0010
AB	 0.6440	 -0.0480
AC	 0.7700	 0.0060
AD	 0.7930	 -0.0020
AE	 0.8070	 0.0040
AF	 0.5570	 -0.0590
AG	 0.8080	 0.0550
AH	 0.7810	 -0.0120
AI	 0.7400	 0.0230
AJ	 0.5090	 0.0130
AK	 0.8520	 -0.0230
AL	 0.9090	 -0.0060
AM	 0.8840	 -0.0660























































































Continued on next page...

Continued from previous page...

Chain	Atom inclusion	Q-score
AN	0.8930	-0.0060
AO	0.9320	-0.0180
AP	0.8930	0.0700
AQ	0.8800	0.0420
AR	0.8770	0.0590
AS	0.8820	0.0590
AT	0.8860	0.0530
AU	0.8880	0.0530
AV	0.8790	0.0550
AW	0.8680	0.0610
AX	0.8700	0.0540
AY	0.9320	0.0520
AZ	0.9260	0.0580
Aa	0.9150	0.0620
Ab	0.8550	0.0050
Ac	0.8440	0.0070
Ad	0.8420	0.0060
Ae	0.8470	0.0240
Af	0.8470	0.0210
Ag	0.8500	0.0010
Ah	0.8470	-0.0010
Ai	0.8530	0.0120
Aj	0.8330	0.0120
Ak	0.8380	0.0220
Al	0.8400	0.0170
Am	0.8330	-0.0030
An	0.8380	0.0150
Ao	0.8250	0.0100
Ap	0.8240	0.0220
Aq	0.8220	0.0220
Ar	0.7990	-0.0070
As	0.8170	0.0120
At	0.8040	0.0090
Au	0.7830	0.0130
Av	0.7640	0.0230
Aw	0.7540	0.0220
Ax	0.7330	0.0120
Ay	0.7150	0.0270
Az	0.6840	0.0260
B	0.8920	0.0640
B0	0.6610	0.0650
B1	0.7850	0.1500







































































Continued on next page...

Continued from previous page...

Chain	Atom inclusion	Q-score
B2	 0.7960	 0.2260
B3	 0.7580	 0.1600
B4	 0.6770	 0.0360
B5	 0.8200	 0.2120
B6	 0.7990	 0.1720
B7	 0.8190	 0.1960
B8	 0.8130	 0.2290
B9	 0.7790	 0.1680
BA	 0.6310	 -0.0230
BB	 0.8260	 0.2040
BC	 0.8190	 0.1960
BD	 0.8040	 0.2280
BE	 0.7580	 0.1960
BF	 0.7230	 -0.0020
BG	 0.8200	 0.2040
BH	 0.7980	 0.1860
BI	 0.7960	 0.2260
BJ	 0.7790	 0.1880
BK	 0.7390	 0.0490
BL	 0.8190	 0.2050
BM	 0.7910	 0.1640
BN	 0.7840	 0.2270
BO	 0.8000	 0.1930
BP	 0.7230	 0.0090
BQ	 0.8220	 0.2080
BR	 0.7770	 0.1480
BS	 0.7900	 0.2290
BT	 0.8000	 0.1740
BU	 0.6920	 -0.0010
BV	 0.8250	 0.2090
BW	 0.7930	 0.1600
BX	 0.8010	 0.2300
BY	 0.7790	 0.1650
BZ	 0.6770	 0.0800
Ba	 0.8190	 0.2100
Bb	 0.8070	 0.1850
Bc	 0.8130	 0.2330
Bd	 0.8000	 0.1900
Be	 0.6460	 0.0450
Bf	 0.8230	 0.2070
Bg	 0.8170	 0.1970
Bh	 0.8050	 0.2280



















































































Continued on next page...

Continued from previous page...

Chain	Atom inclusion	Q-score
Bi	 0.8000	 0.2000
Bj	 0.6610	 -0.0270
Bk	 0.8220	 0.2040
Bl	 0.8090	 0.1920
Bm	 0.8040	 0.2260
Bn	 0.7790	 0.1830
Bo	 0.7230	 0.0140
Bp	 0.8130	 0.2030
Bq	 0.7940	 0.1740
Br	 0.7870	 0.2260
Bs	 0.7790	 0.1860
Bt	 0.7080	 0.0250
Bu	 0.8220	 0.2040
Bv	 0.7860	 0.1540
Bw	 0.7880	 0.2250
Bx	 0.8210	 0.1840
By	 0.7080	 -0.0130
Bz	 0.8280	 0.2090
C	 0.8870	 0.0610
C0	 0.7580	 0.1570
C1	 0.7080	 0.0210
C2	 0.8230	 0.2070
C3	 0.7860	 0.1530
C4	 0.7890	 0.2260
C5	 0.8210	 0.1840
C6	 0.7080	 -0.0090
C7	 0.8290	 0.2110
C8	 0.7860	 0.1490
C9	 0.7950	 0.2290
CA	 0.8180	 0.2100
CB	 0.8080	 0.1910
CC	 0.8100	 0.2300
CD	 0.8000	 0.1950
CE	 0.6310	 -0.0210
CF	 0.8260	 0.2060
CG	 0.8530	 0.1560
CH	 0.6770	 0.0290
CI	 0.8210	 0.2120
CJ	 0.7980	 0.1730
CK	 0.8040	 0.2280
CL	 0.7580	 0.1800
CM	 0.7230	 -0.0020





















































































Continued on next page...

Continued from previous page...

Chain	Atom inclusion	Q-score
CN	 0.8200	 0.2040
CO	 0.7980	 0.1850
CP	 0.7960	 0.2260
CQ	 0.7790	 0.1680
CR	 0.7390	 0.0360
CS	 0.8190	 0.2040
CT	 0.7910	 0.1640
CU	 0.7850	 0.2250
CV	 0.8000	 0.1930
CW	 0.7080	 0.0020
CX	 0.8220	 0.2080
CY	 0.7770	 0.1470
CZ	 0.7900	 0.2270
Ca	 0.8000	 0.1720
Cb	 0.6920	 0.0120
Cc	 0.8250	 0.2100
Cd	 0.7930	 0.1580
Ce	 0.8010	 0.2280
Cf	 0.7890	 0.1580
Cg	 0.6770	 0.0750
Ch	 0.8200	 0.2120
Ci	 0.8080	 0.1830
Cj	 0.8120	 0.2310
Ck	 0.8000	 0.1840
Cl	 0.6460	 0.0320
Cm	 0.8230	 0.2070
Cn	 0.8180	 0.1940
Co	 0.8060	 0.2270
Cp	 0.8000	 0.1980
Cq	 0.6310	 -0.0230
Cr	 0.8230	 0.2050
Cs	 0.8090	 0.1900
Ct	 0.8020	 0.2240
Cu	 0.7680	 0.1840
Cv	 0.7230	 0.0150
Cw	 0.8130	 0.2050
Cx	 0.7930	 0.1730
Cy	 0.7870	 0.2250
Cz	 0.7790	 0.1820
D	 0.8470	 0.0010
D0	 0.4770	 0.1640
D1	 0.9480	 0.0400





















































































Continued on next page...

Continued from previous page...

Chain	Atom inclusion	Q-score
D2	 0.9420	 0.0460
D3	 0.9360	 0.0450
D4	 0.9350	 0.0430
D5	 0.9370	 0.0350
D6	 0.3620	 0.0060
D7	 0.5580	 0.0700
D8	 0.4170	 -0.0210
D9	 0.3960	 0.0290
DA	 0.8580	 0.1350
DB	 0.8340	 0.0760
DC	 0.8390	 0.1020
DD	 0.8630	 0.1570
DE	 0.8650	 0.1690
DF	 0.8340	 0.0880
DG	 0.8410	 0.1010
DH	 0.8420	 0.1400
DI	 0.8630	 0.1600
DJ	 0.8180	 0.0980
DK	 0.8360	 0.0800
DL	 0.8540	 0.1450
DM	 0.8620	 0.1360
DN	 0.8350	 0.0760
DO	 0.8360	 0.0840
DP	 0.8610	 0.1630
DQ	 0.8690	 0.1610
DR	 0.8300	 0.1110
DS	 0.8470	 0.0910
DT	 0.8420	 0.1430
DU	 0.8630	 0.1590
DV	 0.8350	 0.0940
DW	 0.8370	 0.0740
DX	 0.8530	 0.1410
DY	 0.8590	 0.1420
DZ	 0.8390	 0.0910
Da	 0.8370	 0.0820
Db	 0.8620	 0.1670
Dc	 0.8630	 0.1500
Dd	 0.8410	 0.1180
De	 0.8630	 0.1000
Df	 0.8520	 0.1480
Dg	 0.8660	 0.1610
Dh	 0.8260	 0.0810





















































































Continued on next page...

Continued from previous page...

Chain	Atom inclusion	Q-score
Di	 0.8440	 0.0930
Dj	 0.8480	 0.1420
Dk	 0.8590	 0.1530
Dl	 0.8460	 0.1050
Dm	 0.8420	 0.0960
Dn	 0.8600	 0.1650
Do	 0.8610	 0.1410
Dp	 0.8420	 0.0990
Dq	 0.8510	 0.1130
Dr	 0.8610	 0.1520
Ds	 0.8670	 0.1650
Dt	 0.8220	 0.0770
Du	 0.8490	 0.1020
Dv	 0.8420	 0.1380
Dw	 0.8660	 0.1590
Dx	 0.8370	 0.1010
Dy	 0.8440	 0.0950
Dz	 0.9480	 0.0280
E	 0.8750	 0.0000
E1	 0.9470	 0.0190
E2	 0.9570	 0.0210
E3	 0.9600	 0.0140
E4	 0.9570	 0.0170
E5	 0.9600	 0.0210
EA	 0.6790	 0.1430
EB	 0.6910	 0.1390
EC	 0.7140	 0.1040
ED	 0.5240	 0.0620
EE	 0.2980	 -0.0140
EF	 0.3690	 0.0520
EG	 0.9390	 0.0280
EH	 0.9350	 0.0270
EI	 0.9470	 0.0310
EJ	 0.9510	 0.0330
EK	 0.9550	 0.0330
EL	 0.9550	 0.0310
EM	 0.9490	 0.0210
EN	 0.9470	 0.0240
EO	 0.9400	 0.0360
EP	 0.9340	 0.0370
EQ	 0.9250	 0.0360
ER	 0.9110	 0.0320















































































Continued on next page...

Continued from previous page...

Chain	Atom inclusion	Q-score
ES	 0.9060	 0.0300
ET	 0.9100	 0.0290
EU	 0.9150	 0.0290
EV	 0.9170	 0.0320
EW	 0.9210	 0.0330
EX	 0.9360	 -0.0110
EY	 0.9290	 0.0340
EZ	 0.9270	 0.0050
Ea	 0.8950	 0.0040
Eb	 0.9360	 0.0150
Ec	 0.9480	 0.0150
Ed	 0.9470	 -0.0080
Ee	 0.9300	 0.0150
Ef	 0.9440	 -0.0110
Eg	 0.9530	 0.0230
Eh	 0.9350	 0.0000
Ei	 0.8970	 -0.0150
Ej	 0.9300	 0.0290
Ek	 0.9520	 0.0250
El	 0.9360	 0.0270
Em	 0.9380	 0.0260
En	 0.9130	 0.0150
Eo	 0.8950	 0.0130
Ep	 0.9040	 0.0400
Eq	 0.8920	 0.0170
Er	 0.8450	 0.0150
Es	 0.8460	 -0.0030
Et	 0.8240	 -0.0140
Eu	 0.9170	 0.0320
Ev	 0.9200	 0.0250
Ew	 0.9240	 0.0190
Ex	 0.9290	 0.0190
Ey	 0.9320	 0.0200
Ez	 0.9380	 0.0160
F	 0.8650	 0.0300
G	 0.8640	 0.0060
H	 0.8630	 0.0140
I	 0.8510	 0.0050
J	 0.8730	 -0.0120
K	 0.8630	 -0.0030
L	 0.8600	 0.0080
M	 0.8600	 0.0160

Continued on next page...

Continued from previous page...

Chain	Atom inclusion	Q-score
N	 0.8540	 0.0080
O	 0.8590	 0.0090
P	 0.9080	 0.0680
Q	 0.8820	 0.0260
R	 0.8780	 0.0610
S	 0.8830	 0.0360
T	 0.8840	 0.0570
U	 0.8860	 0.0630
V	 0.8770	 0.0670
W	 0.8610	 0.0560
X	 0.8580	 0.0430
Y	 0.8810	 0.0490
Z	 0.8860	 0.0670
a	 0.8850	 0.0620
b	 0.7770	 0.0020
c	 0.8710	 0.0270
d	 0.8560	 0.0200
e	 0.8160	 0.0070
f	 0.8080	 0.0160
g	 0.8780	 -0.0010
h	 0.9450	 0.0380
i	 0.9130	 0.0290
j	 0.9230	 0.0320
k	 0.9300	 0.0350
l	 0.8980	 0.0060
m	 0.8440	 0.0440
n	 0.8770	 0.0520
o	 0.8700	 0.0590
p	 0.8240	 0.0230
q	 0.7900	 -0.0060
r	 0.8860	 0.0190
s	 0.8980	 0.0660
t	 0.8500	 0.0330
u	 0.8830	 0.0450
v	 0.8660	 0.0120
w	 0.8820	 0.0110
x	 0.9890	 -0.0000
y	 0.9140	 0.0370
z	 0.8990	 0.0280